

Xtralift 2.0

10 Person (750kg)

MRL Traction

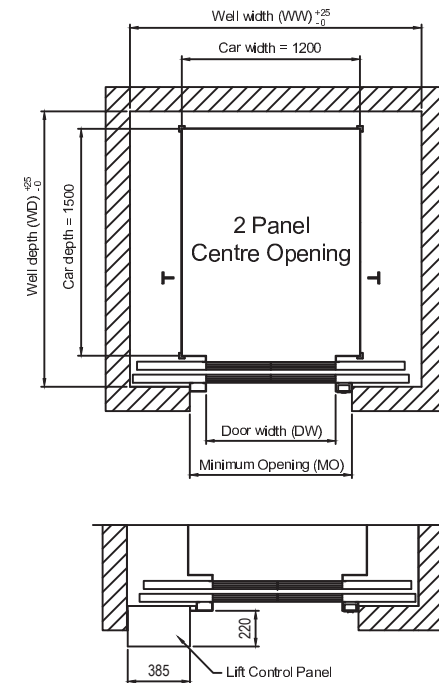
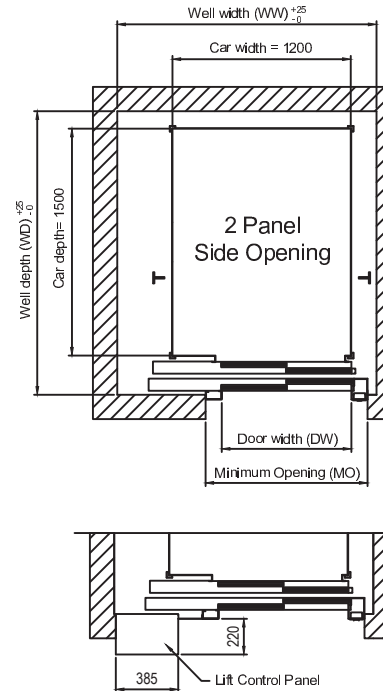
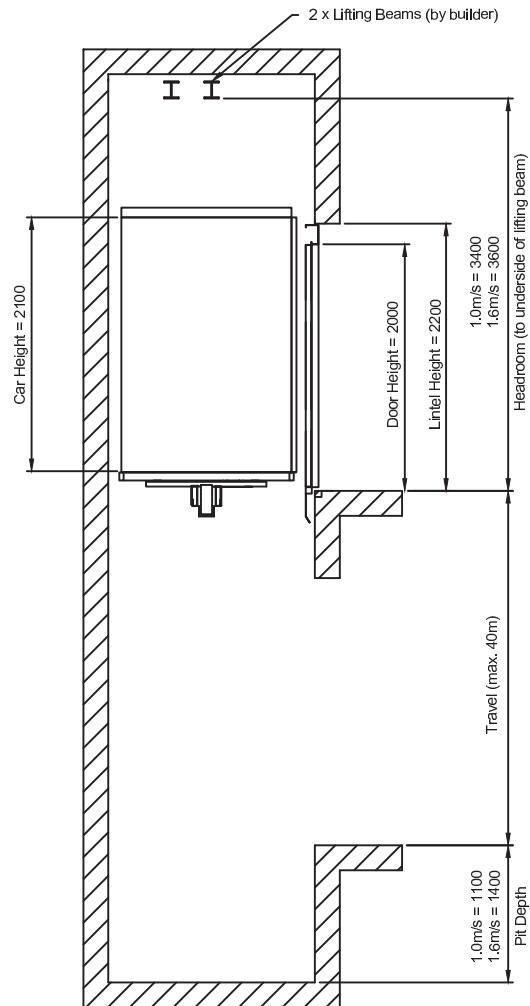

Lift Control Panel located at top floor or one level below. It can be mounted next to the landing entrance or remotely mounted within 5m of the lift shaft

DW	Door type	Shaft Size (1m/sec)				MO	Shaft Size (1.6 m/sec)			
		Single Entrance		Through Entrance			Single Entrance		Through Entrance	
800	Side Opening	1800	1850	1800	2000	1100	1850	1850	1850	2000
	Centre Opening	1800	1800	1800	1900		2000*	1800	1800	1900
900	Side Opening	1800	1850	1800	2000	1200	1850	1850	1850	2000
	Centre Opening	2000*	1800	2000*	1900		2000	1800	2000	1900

Waiver:

This data sheet is for guidance only and must not be used for proper working drawings. Please contact Stannah Lifts for particular details before proceeding. Owing to our policy of continual improvement we reserve the right to alter specifications and dimensions without prior notice.

*Important Note: Please contact Stannah Lifts for particular headroom details.

Stannah Lifts Ltd.
Anton Mill, Andover, Hampshire. SP10 2NX
Tel: 01264 339090
www.stannahlifts.co.uk

Information Sheet
X1-3
26/10/17