

Xtralift 2.0

6 Person (450kg)

MRL Traction

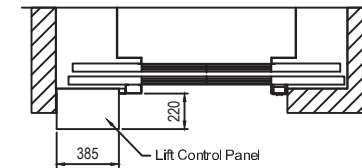
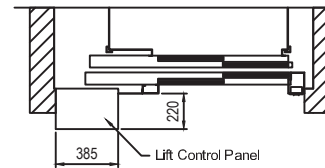
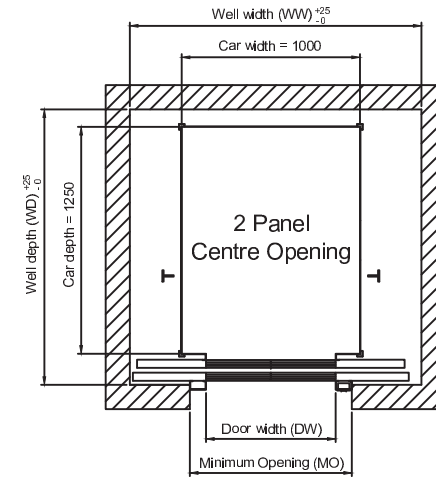
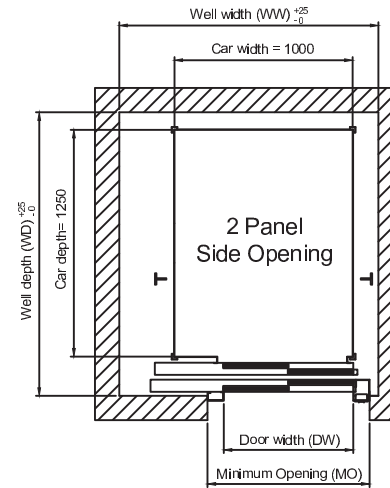
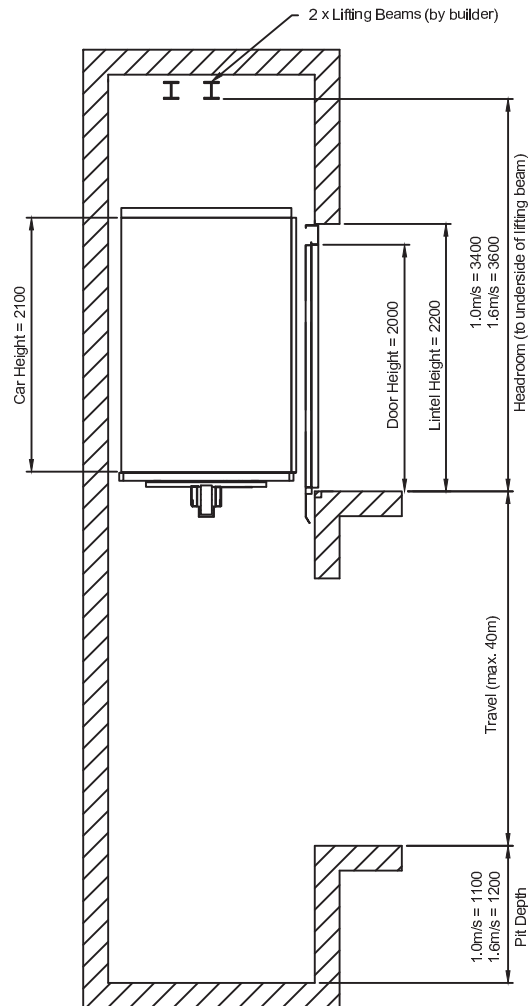

Lift Control Panel located at top floor or one level below. It can be mounted next to the landing entrance or remotely mounted within 5m of the lift shaft

		Shaft Size				MO
		Single Entrance		Through Entrance		
DW	Door type	WW	WD	WD	WD	MO
800	Side Opening	1550	1600	1550	1750	1100
	Centre Opening	1800	1550	1800	1650	

Waiver:

This data sheet is for guidance only and must not be used for proper working drawings. Please contact Stannah Lifts for particular details before proceeding. Owing to our policy of continual improvement we reserve the right to alter specifications and dimensions without prior notice.

Stannah Lifts Ltd.
Anton Mill, Andover, Hampshire. SP10 2NX
Tel: 01264 339090
www.stannahlifts.co.uk

Information Sheet
X1-1
26/10/17