

# TERRY MELODY

## Series of non-enclosed Lifting Platforms

The Terry Melody Lifting Platform offers an aesthetically pleasing solution to the problem of short-rise vertical wheelchair transportation in public buildings (or, where appropriate, domestic situations).

Innovative design. Special emphasis has been placed on the needs of both lift user and the building owner in facilitating compliance with the current legislation for the disabled user / building provider.



*Melody 1, one metre travel*



*Melody 2, two metre travel*

### Part M Building Regulations and Disability Discrimination Act Compliant

- Suited to either inside or outside applications
- Lifting heights up to 2 metres (3.6 metres for domestic use)
- 240 single phase supply with battery back up option
- Direct acting hydraulic drive
- Emergency lowering facility
- Powered gates option
- 250 / 500kg rated load
- No enclosure or support tower required
- Integral ramp eliminates requirement for pit - minimises building work

# Melody 1 standard specification:

|  |   |
|--|---|
| Application range  | Ambulant and Wheelchair users. Internal & External Locations              |
| Rated load   | 250 Kg  |
| Maximum travel   | 1 Metre (1000mm)  |
| Rated speed  | 0.06 m/s  |
| Power supply<br>Electrical requirements  | 220/240V~50/60 Hz-680mA (max)   |
| Low voltage operating system<br>The lift has full battery back-up for emergency lowering | 24VDC   |
| Operating temperature range  | -20°C to +40°C  |
| Safety   | Full platform safe edge which stops the lift should it touch any obstacle |



*Melody 1,  
one metre  
travel external  
installation*

## Melody 1 technical information

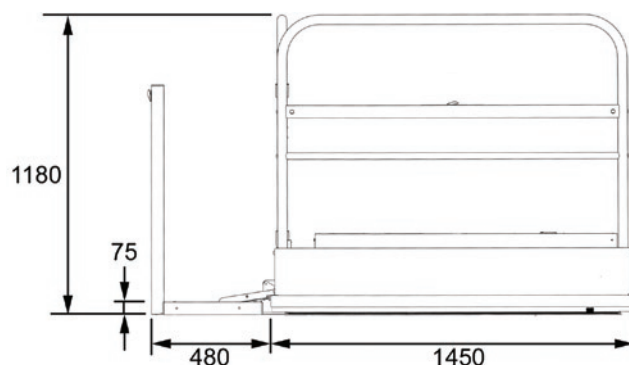
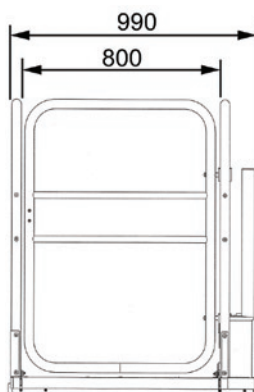
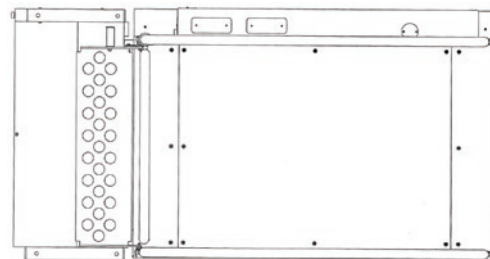

# Melody 2 technical information

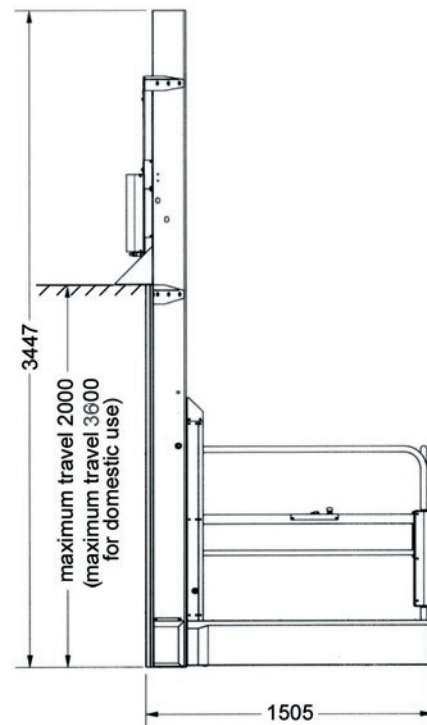
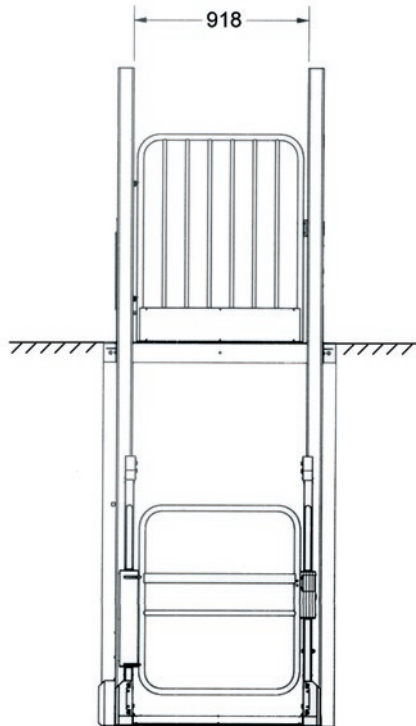

## Melody 2 standard specification:

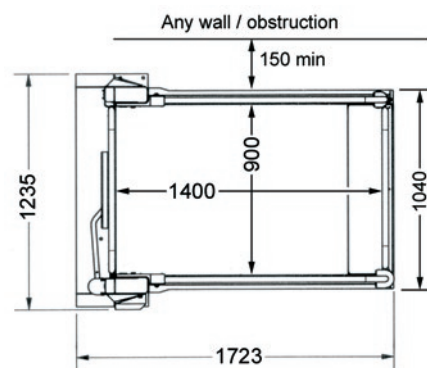

|  |   |
|--|---|
| Application range  | Ambulant and Wheelchair users. Internal & External Locations                |
| Rated load   | 500 Kg  |
| Maximum travel   | 2 metre (2000mm)<br>3.6 Metre (3600mm) for domestic use only                |
| Rated speed  | 0.08 m/s  |
| Power supply<br>Electrical requirements  | 220/240V~50/60 Hz-680mA (max)<br>Dedicated RC protected supply              |
| Low voltage operating system<br>The lift has full battery back-up for emergency lowering | 24VDC   |
| Operating temperature range  | -20°C to +40°C  |
| Safety   | Pressure sensitive surface which stops the lift should it touch an obstacle |

# PUBLIC ACCESS RANGE

## TERRY CONCERTO

### ENCLOSED LIFTING PLATFORMS



The Concerto range of fully enclosed lifting platforms includes all combinations of platform access and shaft styles. Suitable for lifting heights of up to 6 metres. Can be located inside or outside.

## TERRY WHEELCHAIR STAIR LIFT



For wheelchair access where the staircase permits. Slim, automatically folding platform. Can be installed inside or outside.

## TERRY PORTABLE LIFT

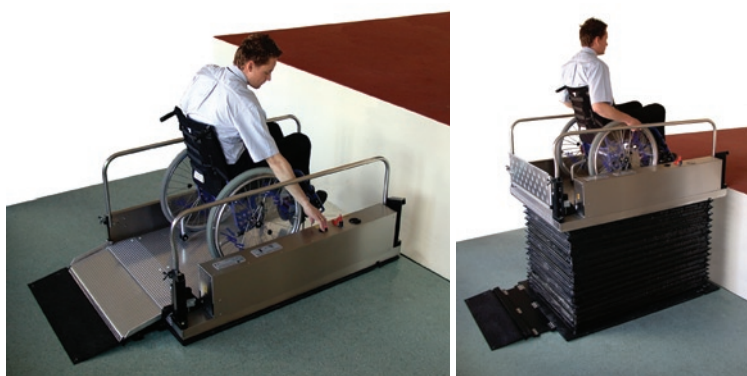

Quick solution to provide temporary access up to 1 metre. Folds up for easy storage.



**Terry Group Ltd.**  
Longridge Trading Estate,  
Knutsford, Cheshire  
WA16 8PR, England



Tel: 00 44 (0) 1565 650376  
Fax: 00 44 (0) 1565 755062  
web: [www.terrylifts.co.uk](http://www.terrylifts.co.uk)  
email: [sales@terrylifts.co.uk](mailto:sales@terrylifts.co.uk)

Terry Lifts' policy is one of continuous product development and the company reserves the right to change specifications, including standard colours, without notice