

Stannah Lifts Technical Bulletin

Issue No: M23 Date: 26/05/2004 Page: 1 of 1

LIFT TYPE: Hydraulic passenger lift, MXL finish

Roof assemblies:

Following requests from installers, MXL roofs will now be sent out in 2 pieces, the roof and the ceiling. These will then be assembled on site so as to ease manual handling.

Procedure:

Apron:

Unwrap the roof panel assembly and lean against a wall or other suitable stable surface. Unwrap the ceiling infill-panel and attach to the roof assembly with fixings provided. See the diagram below for general assembly.

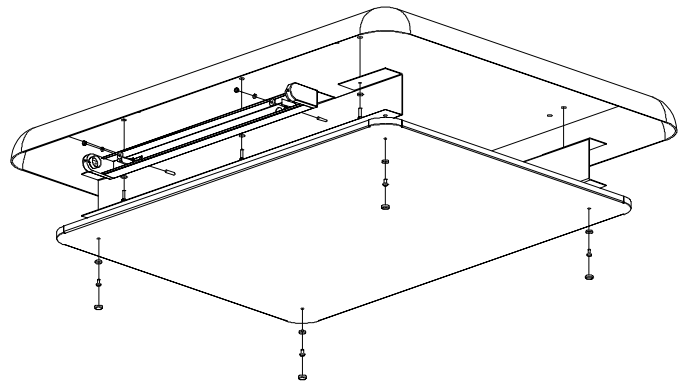

Down Lighter:

Unwrap the roof panel assembly and lean against a wall or other suitable stable surface. Unwrap the down lighter panel assembly and attach to the roof with fixings provided, taking care to route the cables through the holes provided. See the diagram below for general assembly.

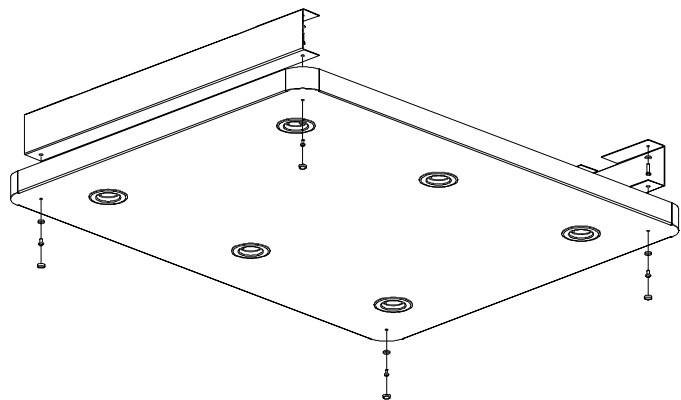

Any queries relating to this part should be directed to,

Mr Philip Mean, Stannah Lifts, Anton Mill, Andover, SP10 2NX,
Tel: 01264 339090 ext 289