

TECHNICAL BULLETIN

For the Attention of : Service Engineers, Installers, Trade Customers, Testers, Training Dept, H & S Manager etc.....

Date : 07/04/08

Product : New Plastic Wedge Clamp

Subject : Wall and Structure Mounted Trailer Clamp all Lifts

Status : Product Update Information only

Pages : 1

Originator : Stannah Lifts Ltd, Anton Mill, Andover, Hants SP10 2NX 01264 339090

Details

We have recently introduced a change to the trailer cable clamping device on all wall mounted and structure lifts. The original manufactured wall mounted and structure trailer cable bracket has been superseded by the new plastic wedge clamp device shown below.

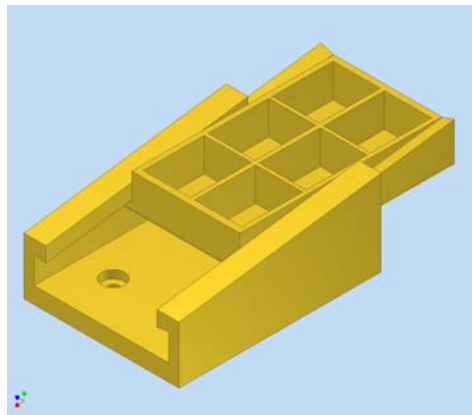

The fixing of the new bracket to the wall and structure has not changed, 4 off fixings will be supplied with each clamp. On MRLi architrave and MRLi pit contracts 1 off clamp will be supplied with fixings; for MRLi remote, MRC and Motor room contracts 2 off clamps will be supplied with fixings.

Summary:

- Please fit the new wedge clamp in the same way you would the old.
- When trailing the trailing cable around the shaft please use the cable tray provided where required.