

TECHNICAL BULLETIN

For the Attention of : Installers, Trade Customers, Service Engineers, Testers.

Date : 7th March 2007

Product : Machine Room-less System 21 Passenger Lifts

Subject : Modification to Remote Hand Pump Housing.

Status : Information only.

Pages : 2

Originator : Stannah Lifts Ltd, Anton Mill, Andover, Hants SP10 2NX 01264 339090

Detail

A modification may be necessary where a replacement hand pump is fitted to a lift manufactured before February 2007.

Changes have been made to the design of the remote hand pump unit that will make it necessary to modify the hand pump housing located in the lowest landing entrance. Material must be cut away to accommodate a new fitting that has been added to the bottom of the hand pump block. See below for cut-out details.

Note: In some instances it may be necessary to carryout this modification during installation.

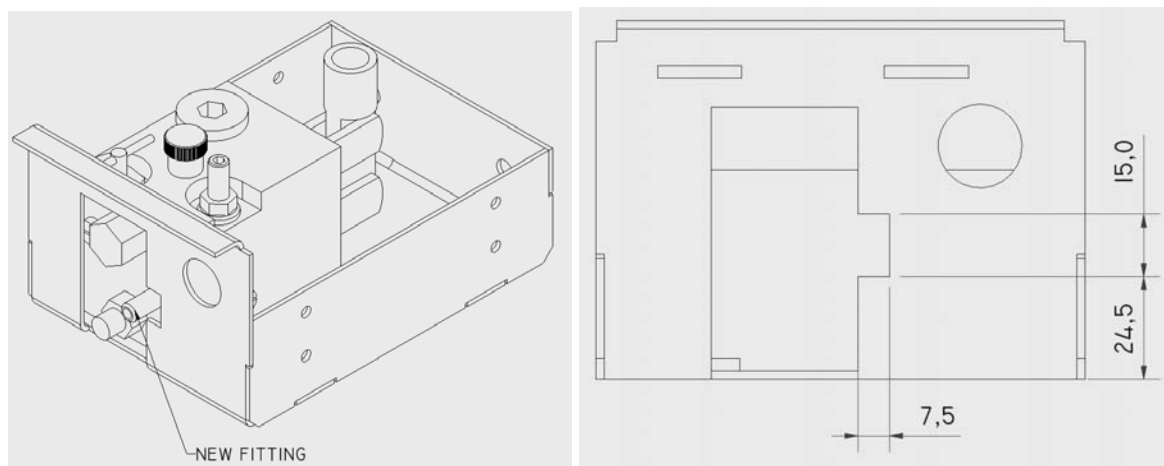
Hand Pump Located in Right Hand Landing Upright

Hand Pump Located in Left Hand Landing Upright

