

**TECHNICAL BULLETIN**

---

**For the Attention of :** Installers, Trade Customers.

**Date :** 7<sup>th</sup> March 2007

**Product :** System 21 Passenger Lifts

**Subject :** Alternative fixings for mounting of landing door top track.

**Status :** Information only.

**Pages :** 2

---

**Originator :** Stannah Lifts Ltd, Anton Mill, Andover, Hants SP10 2NX 01264 339090

---

**Detail**

Due to a number of top track mounting angles having been manufactured with an 8.5mm wide slot, it will not be possible to use the M10 fixings normally supplied with the lift.

On those lifts that are affected, the M10 fixings can be discarded and replaced with the M8 fixing kit as shown in the diagram below.

This applies to all 800mm and 900mm wide 2-panel side opening and centre opening entrances.

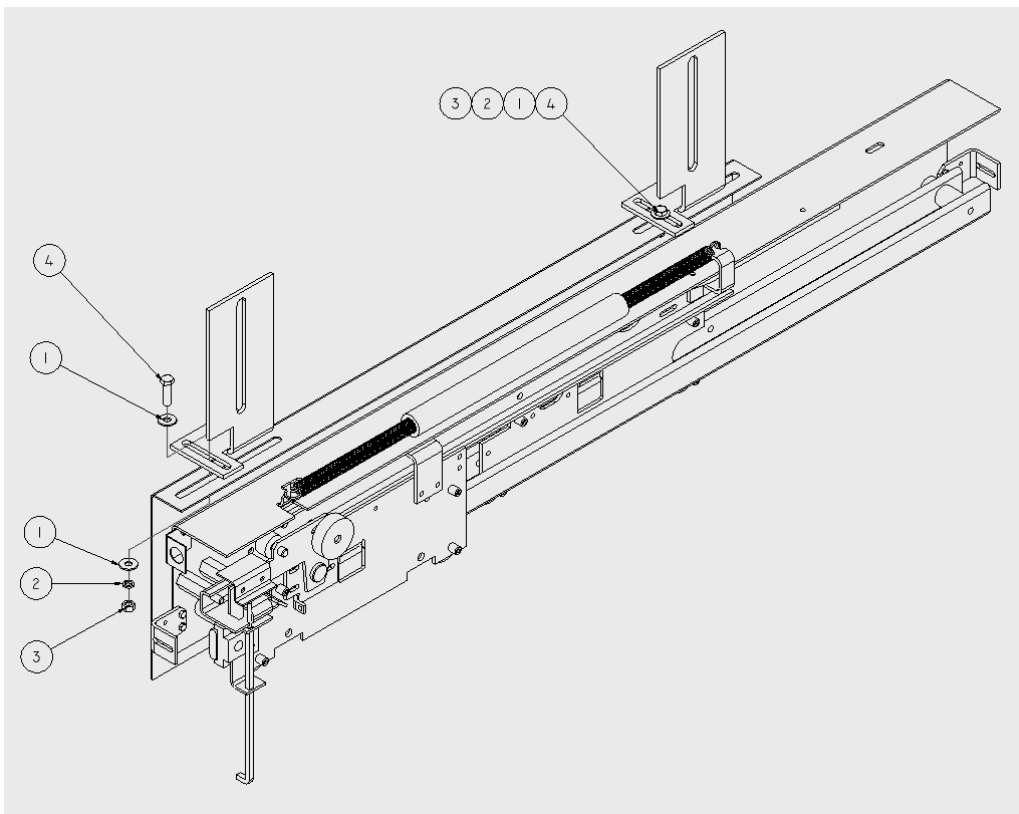

TOP TRACK FIXING KIT			
ITEM	DRG NUMBER	DESCRIPTION	QTY
4	500947	M8 x 30 HEX HD SCREW	2
3	500092	M8 FULL NUT (BZP)	2
2	500089	M8 SPRING WASHER	2
1	500458	M8 PLAIN WASHER (FORM C)	4

Note: 1 kit is required per landing entrance.

### **Summary**

- 1) Discard M10 fixings
- 2) Fix using M8 fixing kit as shown in the diagram. Note: A large diameter washer should be used on both sides of the joint.