

LIFT TYPE: Hydraulic passenger lift with mirror fitted in the lift car

Mirror Packaging and PVC trims:

For a number of months Stannah have been sending out the lift car mirrors packaged only with corner guards and foam pipe lagging on the top and bottom edges of the mirrors. This system has helped to reduce the number of breakages during delivery and on site and will continue for the foreseeable future.

Following the introduction of the new interior lift cars a new mirror fixing method was also introduced. This evolved a slight change to the s/steel mirror trims and the addition of plastic PVC edging to the top and bottom edges of the mirrors. The PVC edging remains on the mirror during installation and is inserted into the mirror trims (see diagram below).

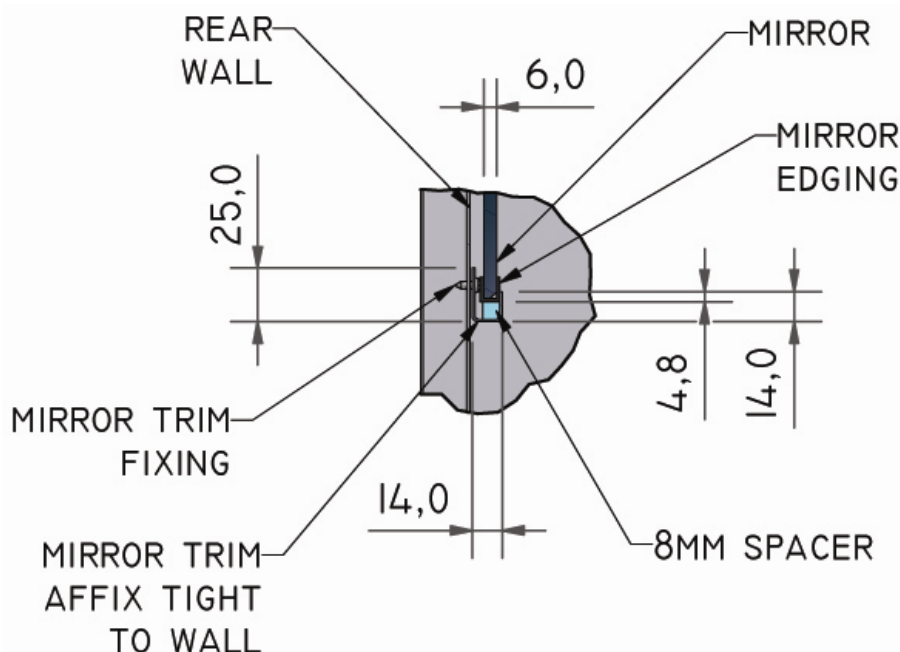

(Lower mirror trim shown)

For more details on fitting mirrors and any other parts of the new finishes please refer to the relevant installation guide, available from Stannah and also on the technical web site.

Any queries relating to this part should be directed to,

Mr Philip Mean, Stannah Lifts, Anton Mill, Andover, SP10 2NX, Tel: 01264 339090