

To: Stannah Lift Services Ltd
Trade Customers

Stannah Lifts Safety Bulletin

Issue No: M20

Date: 20/08/03

Page 1 of 1

LIFT TYPE: - Stannah Hydraulic Passenger Lifts with 2:1 Roping

Component Failure

We have experienced a problem with a steel bracket on a 4 year old lift, which appears to have cracked before eventually failing. The bracket design has been in use since 1986.

The bracket is fitted at the base of the tackle pulley assembly which supports the main suspension ropes and secures the top of the piston to the tackle pulley assembly (*see picture below*).

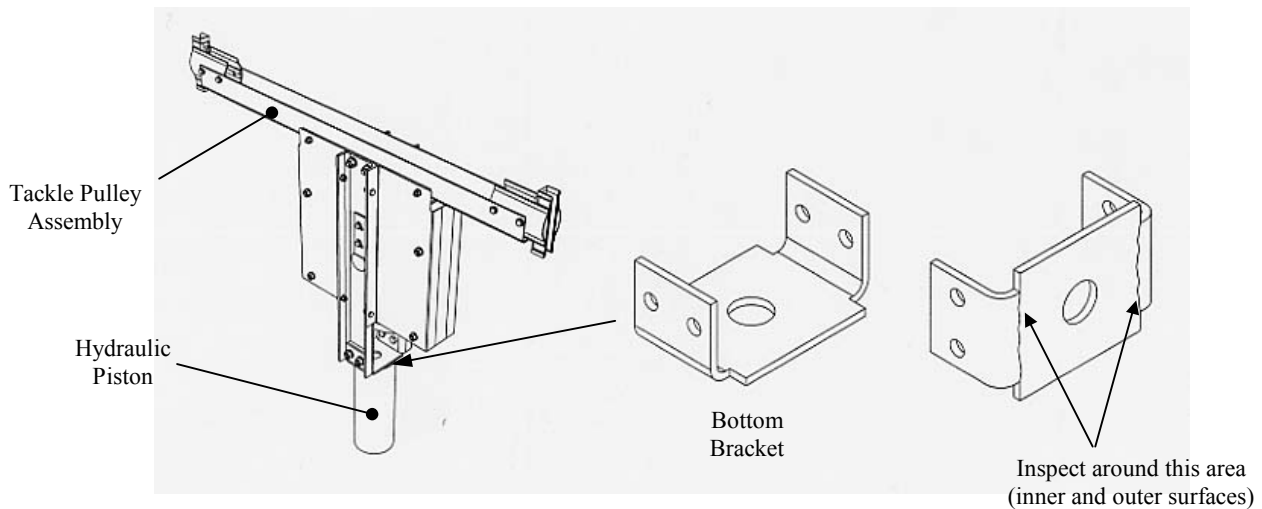

ACTION

During the next service visit, inspect the bottom bracket carefully for any signs of cracking, distortion or other imperfection on any Stannah Hydraulic Passenger Lift with 2:1 roping.

Please notify Pete Jeffery of any concerns.

Mr. Peter Jeffery, Stannah Lifts, Anton Mill, Andover, Hants, SP10 2NX

Tel 01264 339090 ext 300