

**TECHNICAL BULLETIN**

**For the Attention of :** Access Installers

**Date :** 23.10.07

**Product :** Midilift SL and Stairiser SX.

**Subject :** RCD installation detail.

**Status :** Information only.

**Pages :** 1

**Originator :** Stannah Lifts Ltd, Anton Mill, Andover, Hants SP10 2NX 01264 339090

**Summary**

To reduce the high number of site revisits due to electrical supply problems, RCD's will now become van stock for all access installers. This will allow the installation and test procedure to be completed on sites where the builder has not fitted an RCD.

**Detail**

The following diagram indicates exactly where in the mains supply circuit that the RCD is to be installed (Note: the RCD must be mounted within close proximity of the lift) –

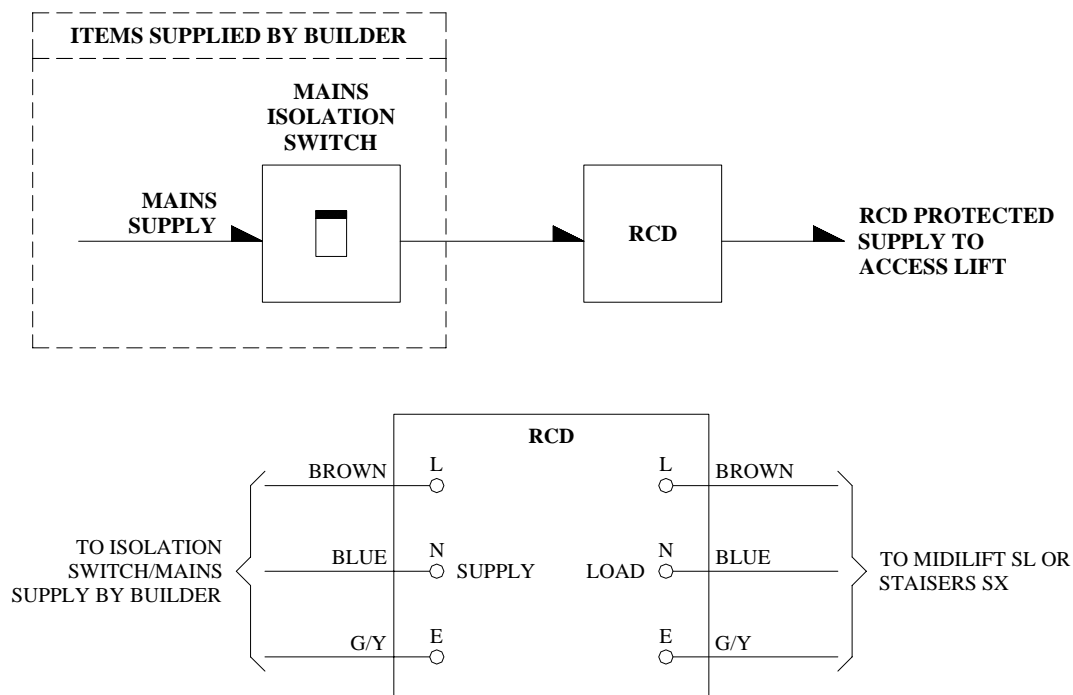

Testing of the RCD will still be via the procedure outlined in the relevant 'certificate of test and examination after installation' document.