

To: Installers,  
Trade Customers,  
Training Centre,  
Stannah Services.

## *Stannah Lifts Technical Bulletin.*

**Issue No: M36.**

**Date: 28/04/06.**

**Page 1 of 3.**

### *LIFT TYPE: - Stannah Midilift SL Vertical Platform Lift.*

#### **Introduction**

Correct Installation of 1 hour fire rated door.

#### **Description**

The Midilift SL 1 hour fire door can be specified as a special option. There are a few notable differences in the way this option should be fitted from the standard ½ hour fire door and the components used.

#### **Fire Door and Frame**

The door itself is noticeably different from the standard door in that it has two 15mm wide grooves around the sides for intumescent strips and is thicker at 54mm. The door is also 5kg heavier (80kg) than the standard fire door.

The door frame is 60mm wide which is 10mm wider than standard.

#### **Door Locks**

The shoot bolt extension piece fitted to the 1 hour fire door lock is 10mm longer than standard. It should measure 55mm overall length and 50mm from the shoulder.

***NB It is important*** that the correct extension piece is fitted so the bolt will engage correctly with the door. The bolt should engage by 10-12mm but **engagement must be at least 7mm.**

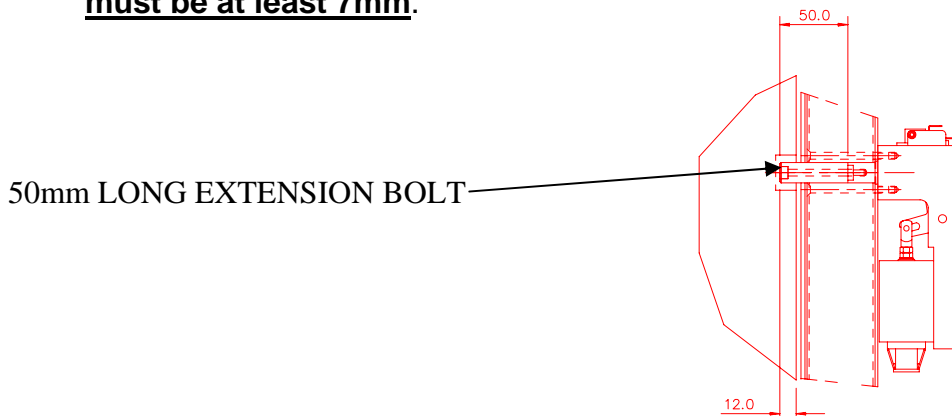

**BOLT ENGAGEMENT INTO DOOR MUST BE AT LEAST 7mm**

### Intumescent Strip.

The 1 hour fire door has a different Intumescent strip arrangement than the standard door.

It is important that the supplied 2mm thick Intumescent pads are fitted between the hinges and the wooden door. **Failure to fit these items may mean the door will not operate correctly and the fire seal compromised.**

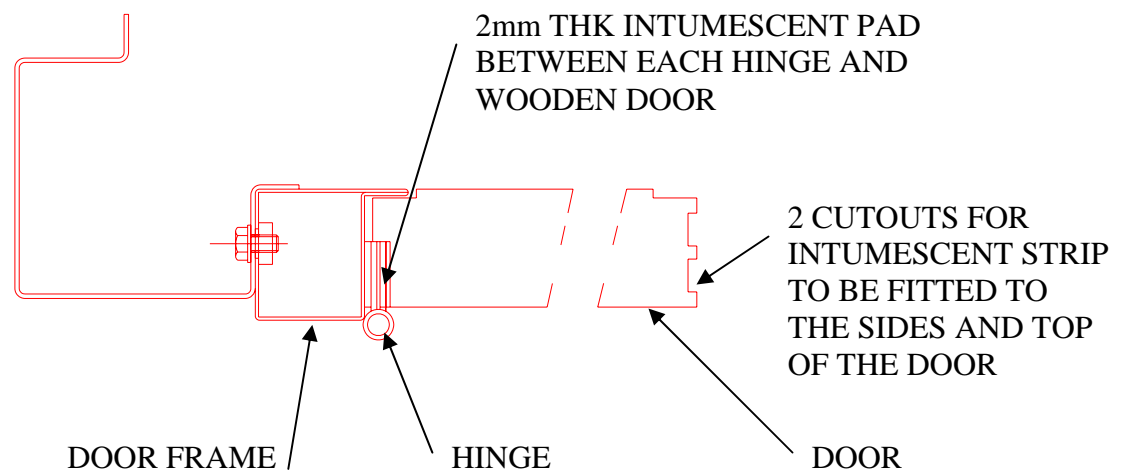

Intumescent strips should be fitted to the two routed channels on the sides and top of the door. **Both sets of strips** are required to be fitted to ensure the fire seal is not compromised.

## Door closers

**The manual door closer** should be mounted as per the paper template supplied with the closer and is to be positioned in line with the centre of the hinges as indicated on the template.

**The power door operator** should be mounted so that the backing plate is in line with the centreline of the hinges (see diagram). The slide channel should be mounted 149mm away from the hinge side of the door and **must** have the 6mm packer fitted to allow correct

