

To: Installers,
Trade Customers,
Training Centre,
Stannah Services.

Stannah Lifts Technical Bulletin.

Issue No: M34.

Date: 27/02/06.

Page 1 of 2.

LIFT TYPE: - Stannah Midilift SL Vertical Platform Lift.

Introduction

Midilift SL gate powered closer fitment and recommended fixing positions.

Description

The Midilift SL powered gate is an option which utilises the Ditec Sprint automatic door closer unit and a Stannah linkage arm. This is detailed in the extract from drawing 6101072:

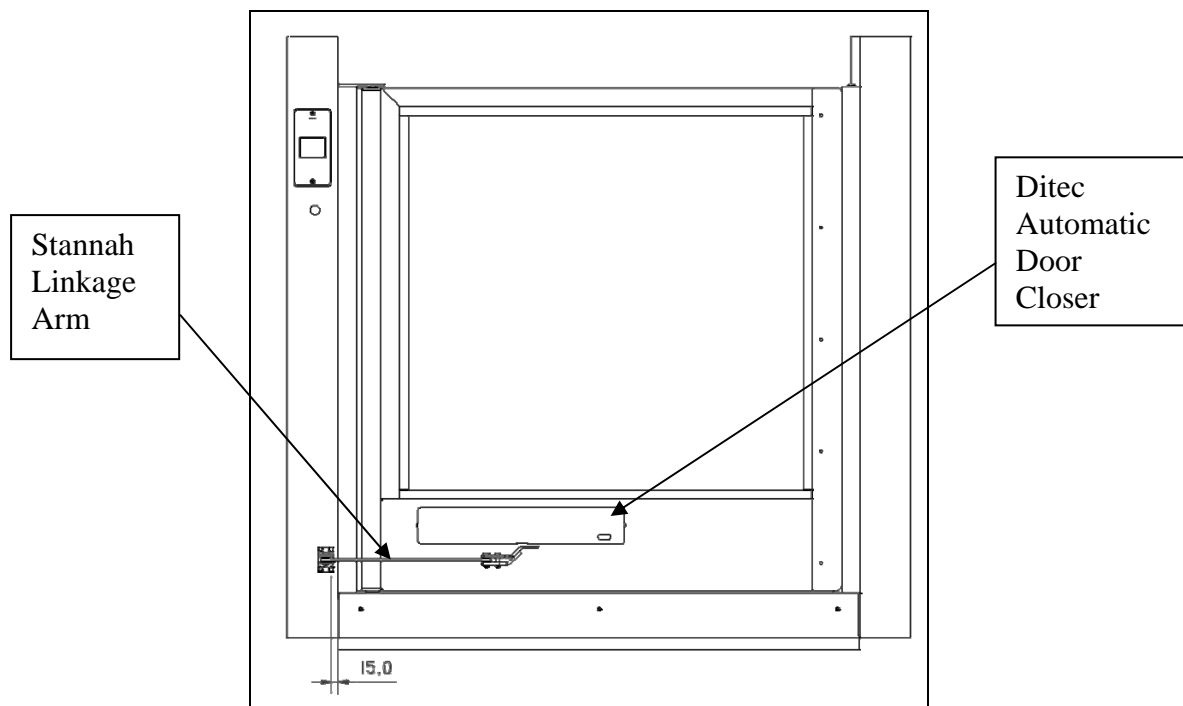

Extract from 6101072.

The link arm assembly is pre-attached at one end to the Ditec Sprint automatic door closer unit while the fixing bracket at the other end is attached to the corner upright in the following position shown by extract 2 from 6101072 (see page 2):

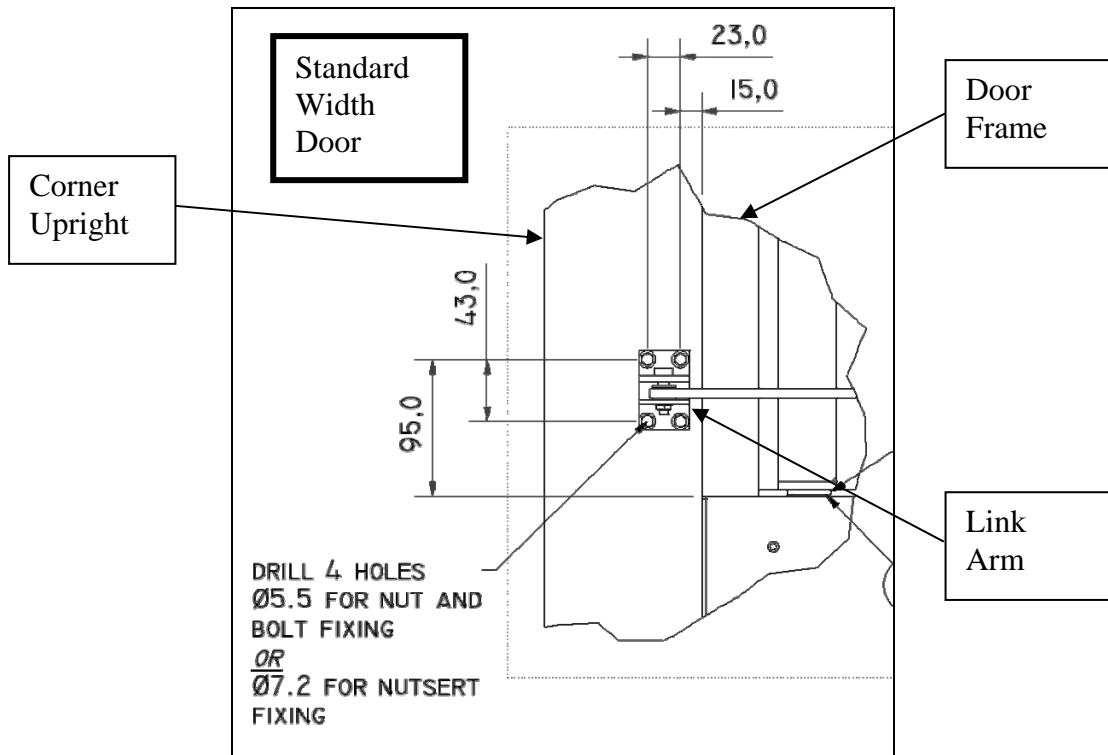

Extract 2 from 6101072.

These dimensions shown are for the standard width door only. The dimensions shown apply to right and left hand slam configurations.

The reduced width doors are to be fixed as shown by the extract from 6101074:

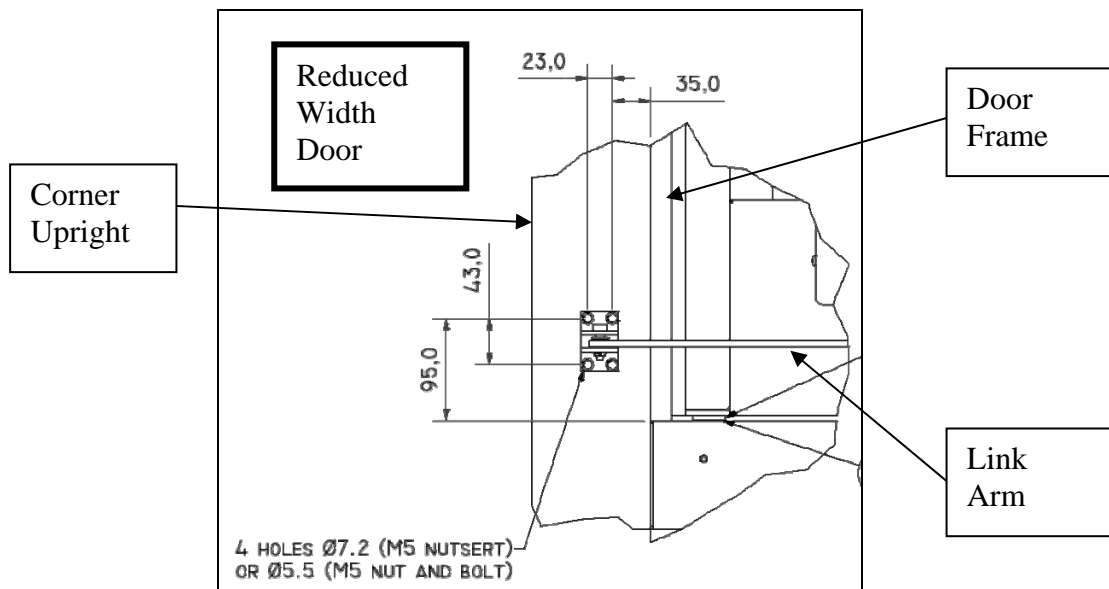

Extract from 6101074.