

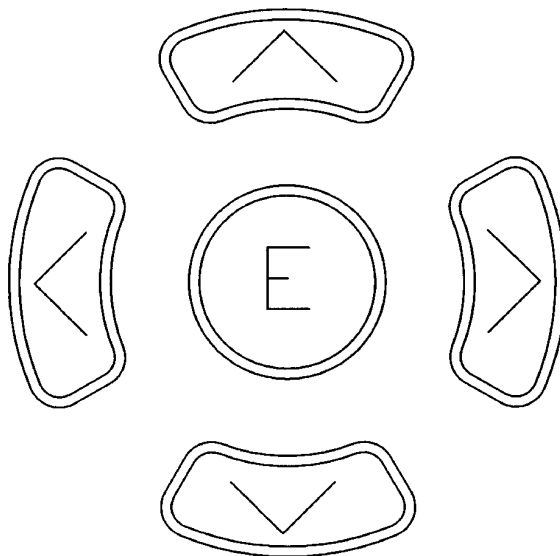

NEXUS

3rd GENERATION LIFT CONTROLLER

**REFERENCE
MANUAL**



INSTALLATION AND PROGRAMMING MANUAL

CONTENTS

1. Introduction. Page 5.
 - 1.1 Nexus Lift Controller standard features.

2. Overview of 3rd Generation Lift Controller. Page 7.
 - 2.1 Environmental Requirements and Standards.
 - 2.2 Unit Construction.
 - 2.3 Power supply requirements.
 - 2.4 Input voltages.
 - 2.5 Output voltages.
 - 2.6 Output short circuit protection.
 - 2.7 Front panel LED indication.
 - 2.8 Programming and Fault logging.
 - 2.9 Dimensions and mounting points.

3. Manner of Operation. Page 13.
 - 3.1 Lift Call Handling in Normal Service.
 - 3.1.1 Single Button Collective (SBC).
 - 3.1.2 Fully Directional Collective (FDC).
 - 3.1.3 Highest Call Down Collective (HCDC).
 - 3.1.4 Lowest Call Up Collective (LCUC).
 - 3.2 Stuck Button.
 - 3.3 Call Handling out of Normal service.
 - 3.4 Lift Travel / Movement and floor level control.
 - 3.5 Operation of floor levelling.
 - 3.6 Operation of Floor re-levelling (Anticreep).
 - 3.7 Short Floor Travel.
 - 3.8 Reset Floor.
 - 3.9 Lift over travel protection. (Ultimate Limit).
 - 3.10 Lift over journey protection.
 - 3.11 Door operation.
 - 3.12 Advance Door Opening.
 - 3.13 Door controls and Door Nudge.
 - 3.14 Auxiliary Doors.
 - 3.15 Open through car with sequential door opening.
 - 3.16 Door programmable parameters.
 - 3.17 Door programmable parameter specific to a floor.

CONTENTS

4. Inputs and function.	Page 21.
4.1 Power Supply.	
4.2 Safety Circuit inputs.	
4.3 Door inputs.	
4.4 Run inputs.	
4.5 Proximity inputs.	
4.6 Lift Control inputs.	
4.7 Call inputs.	
5. Outputs and function	Page 31.
5.1 Call acceptance.	
5.2 Position and direction.	
5.3 Signal outputs.	
5.4 Run outputs.	
5.5 Door outputs.	
6. Programming and Fault logging interface.	Page 37.
6.1 Introduction.	
6.2 Description of operation.	
6.3 Lift Status.	
6.4 Lift Event table.	
6.5 Clearing event table.	
6.6 Event options.	
6.7 Lift Starts log.	
6.8 Registering calls.	
6.9 Set and View register.	
6.10 Clock settings.	
6.11 Setting site number.	
6.12 Programming options.	
6.13 Programming door options.	

END OF DOCUMENT.

INSTALLATION AND PROGRAMMING MANUAL

APPENDICES

APPENDIX A: Technical Specification.	Page 45.
APPENDIX B: Template for Mounting points.	Page 47.
APPENDIX C: Front panel abbreviations.	Page 49.
APPENDIX D: Call input and acceptance wiring.	Page 51.
APPENDIX E: Input ratings and descriptions.	Page 53.
APPENDIX F: Output ratings and description.	Page 57.
APPENDIX G: Typical wiring diagram.	Page 61.
APPENDIX H: Dimensions for UPR, DPR and ACR vanes.	Page 63.
APPENDIX I: Short floor vane arrangement.	Page 65.
APPENDIX J: Circuit diagram for double door access.	Page 67.
APPENDIX K: List of menus and details.	Page 69.
APPENDIX L: Event messages and event options	Page 71.
APPENDIX M: Set and view registers lists.	Page 73.
APPENDIX N: List of programmable parameters.	Page 75.
APPENDIX O: Instruction for changing program memory.	Page 77.

1 INTRODUCTION

The 3rd Generation Lift Controller, here after referred to as the Nexus Lift Controller, has been developed to incorporate the best features of the previous generations of lift controllers and to comply to the latest Lift directives EN81/2 and EMC EN12015 and EN12016, as well as specific customer requirements. Such as: short floor travel, double doors, output short circuit protection, clear labelling of inputs and outputs, front panel LED indication and built in programmer with fault logging in plain English on a 4 by 20 back lit liquid crystal display (LCD). Faults are logged with the time and floor position where the faults occurred.

Future developments include multi car group operation, remote monitoring and serial communication for lift car and landing wiring.

The call handling capabilities of the standard Nexus Lift Controller is 8 floors for a single button, up or down collective and 6 floors for a full collective system. The unit can be expanded, by addition of plug in boards, to 15 floors for both types of call system.

Setup security is assured by the use of an electronic key. The programmable parameter can only be set when the key is plugged into the RS232 port. Without the key it is not possible to change the programmed parameters. This ensures that the Nexus Lift Controller programmable parameter settings are only adjusted by competent personnel. Electronic keys have a limited life. The expiry date for the key is marked on each key. It is the responsibility of the user to ensure that their key is still valid. Only authorised personnel can obtain a replacement key from Stannah Lifts Ltd.

The Nexus Lift Controller and software have undergone extensive in house and site testing to ensure product reliability and performance meet the requirements of a modern lift controller and customers expectations.

1.1 Nexus Lift controller Standard features.

- General.
 - Designed using state of the art Microprocessor Technology.
 - Incorporates the best of generation 1 and 2 Lift controllers.
 - Complies with the latest lift directive EN81/2. (1998).
 - Clear labelling of inputs and outputs.
 - Input and output LED status indication.
 - Connection to unit via plug and sockets.
 - Built in programming and fault logging.
 - Messages displayed in Plain English.
 - Front Panel LED lift status indication.
 - Program security by the use of a plug in electronic key.
 - Communication ports RS232 and two RS485 ports.
 - Self-test and CPU status indication.
 - Stuck button detection and indication.

Introduction

- ❑ Call Handling.
 - 8 Floor operation for Single Button Collective.
 - 6 Floor operation for Fully Directional Collective.
 - Expandable up to 15 Floors.
 - Call acceptance illumination outputs for all call inputs.

- ❑ Door controls.
 - Programmable for automatic or manual doors.
 - Door open pushbutton.
 - Extended Door open pushbutton.
 - Programmable park open per floor.
 - Door close pushbutton.
 - Door nudge (low torque close) option.
 - Door protection sensitive edge input.
 - Double door operation.
 - Door control speech trigger outputs.
 - Door alarm output for manual doors.

- ❑ Lift control outputs.
 - Automatic re-levelling.
 - Programmable options for re-levelling.
 - Floor position output options.
 - One per floor.
 - Binary.
 - Gray code.
 - Direction arrow outputs.
 - Hall lantern outputs.
 - Directional arrival gong outputs.
 - Lift in service output.
 - Overload warning output.

- ❑ Control options.
 - Goods control. (Landing call buttons disabled).
 - Test control.
 - Firecontrol compliant to EN81/2.
 - Two shutdown inputs.
 - Two overload condition inputs.
 - Alarm input.
 - Motor over temperature shutdown to EN81/2
 - Short floor travel inputs.
 - Built in over journey timer.
 - Built in latching of dangerous fault conditions, such as Ultimate limit and over journey time out.

- ❑ Future options.
 - Multi car group operation.
 - Remote monitoring.
 - Serial communications.

2.1 Environment requirements and standards.

See Appendix A for full specification.

The controller has been designed to work in the following environment:

Ambient Temperature (operating): 0 to 40 °C.

Ambient Temperature (storage): -10 to +70 °C.

Ambient Humidity: The assembly can be manufactured for environments with high levels of humidity or pollution, such as conductive dust particles. The requirement for the unit to work in a high humidity or polluted environment must be specified when placing the order.

The Nexus Lift Controller has been designed to meet the requirements of the latest Lift and EMC directives:

Lift directive EN 81/2:1998.

EMC standards EN 12015 for emissions.

EMC standards EN 12016 for immunity.

2.2 Unit Construction.

Dim: 404 x 200 x 128mm

See Appendix B for template of mounting points.

The unit has two unhandled M5 keyholes for mounting the unit to the controller panel. Because of this, ensure unit is the correct way up before mounting on the control panel.

The standard Nexus Lift Controller assembly consists of an Aluminium enclosure with a label / keypad mounted on a hinged front panel. Inside the enclosure there are four circuit boards, these are.

LED board: Mounted on the front panel, used to indicate the status of the Lift.

LCD board, mounted on the Processor board (CPU), is used to display lift status information.

Processor board (CPU): Mounted on to the Main I/O board. The CPU board contains the lift software and controls the unit.

Main I/O board: Mounted in the base of the unit. This board provides the interface to the outside world

The standard unit can be expanded for up to 15 floors by the addition of one or two expansion boards, these plug into the Main I/O board.

Connection to the unit is via plug and socket Wago cage clamp connectors. These enable the removal of the unit without the need to rewire terminals.

2.3 Power supply requirements: 9 V ac or dc, 1.3 A ac.

The Nexus controller can be powered from 9 Volts ac or dc supply and draws a worst case current of 1.3 Amperes. A transformer winding with a 20 VA Rating would provide a suitable power source. This transformer or winding should not be used to power any other devices as heavy inductive loads may cause noise problems. This is a precautionary measure rather than a necessity.

2.4 Input Voltages. 12/24 V dc or 110 V ac or dc.

See Appendix E for detailed list of Inputs and ratings.

All the inputs with the exception of the Alarm input, of the Nexus Lift Controller are rated for a nominal voltage of 110 V ac or dc. The full range is for 60v to 120v. The Alarm input is rated for 12 or 24 V ac or dc, as shown on the label.

Connection to the inputs is via Wago cage clamp plug and socket connectors, supplied with the unit.

2.5 Output Voltages. 12/24 V dc or 110 V ac or dc.

See Appendix F for detailed list of outputs and ratings.

The outputs of the Nexus Lift Controller source/feed a voltage when in the ON condition.

The call acceptance, position, direction, signal outputs and LIS and OLW outputs, are driven by solid state devices: Transistors or Mosfets. These outputs are 12 or 24 Vdc. The voltage is selected by wiring to two separate feed inputs marked 12V/24V. One feed is used for call acceptance, position and RU/RD, the other feed is used for the signal outputs.

The Run and Door outputs are relay driven outputs with volt free contacts, the feed to relay contacts are grouped by function:

The Run outputs URR, DRR, HSR are fed from the input marked GR, this should be wired to contacts on the safety chain contactor GR.

The re-levelling/anticreep output AC feed is marked AF, this should be wired to the AF terminal, which is before the door lock circuit.

The Door outputs ODR, CDR and DOA are labelled for the relay contact terminals.

The feed for the outputs AC, SPA3, SPA4, RR and DNR is labelled AF. This should be wired to the AF terminal point on the control panel.

The nominal voltage for these outputs on a Stannah Lifts control panel is 110V ac.

Connection to the outputs of the Nexus Lift Controller is via Wago cage clamp plug and socket connectors.

2.6 Output Short Circuit Protection.

The Call acceptance, Position and Direction arrow outputs will current limit at 0.3 A. If a short circuit occurs the output group will turn OFF and a fault message will be logged. The output group will turn back ON when the fault is cleared.

The Run and Door outputs are protected by two circuit breakers. These are labelled GR and AF. The circuit breaker trip at approximately 5A. To clear a fault requires the circuit breaker to be manually reset. This is done by pushing in the circuit breaker levers recessed in the side of the unit, below the circuit breaker symbols shown on the label.

The Signal, LIS and OLW outputs are protected by plug in 1A quick blow fuses. These are mounted on the main PCB close to the FET devices. See Figure 2 for fuse location. A replacement fuse can be obtained from RS Component part No 417-436, or Farnell Components part No 529-394, The fuse may be removed by simply unplugging the device, a pair of pointed nose pliers may be required for the removal of a fuse.

The 12V/24V dc output circuits are protected from reverse connection by blocking diodes in the output circuit.

2.7 Front panel LED indication.

See Appendix C for details of abbreviations and status.

The LEDs on the front panel are used to indicate the status of the lift and are laid out in a similar manner as a key wiring diagram. The lift signals that are shown are grouped as follows:

Nexus status: CPU, SCAN, FAULT, SB, RS232, RS485, RS485.

Power and Safety chain status: 110VAC, 110VDC, 12VDC, 9VAC, ULR, AF, G1, G2, G3.

Overview

Run, Door, Proximity and Control inputs: UC, DC, HSC, AC, ODL, CDL, ODLA, CDLA, UPR, DPR, ACR, GCR, TRC, FMC, SDL.

Position, Car, Up and Down Call acceptance: The LEDs 1 to 15 are used to indicate the Lift position and call acceptance information. The leds marked 'POSITION', 'CAR', 'UP', and 'DOWN' indicate what information leds 1 to 15 are displaying.

The key marked S, see Figure1, is used to select which of the four options is displayed on the leds 1 to 15. The default display is position.

2.8 Programming and Fault Logging.

The built in programmer/logger incorporates a 4 x 20 character Liquid Crystal Display (LCD), which enables lift menus, status, event and programmable options to be displayed in plain English

The front panel of the unit has five keys marked \wedge , \vee , $<$, $>$ and E. The arrangement of the keys are shown in Figure 1, below. These are used to select one of eleven menu items and set programmable parameters. See section 6 for information on programming and logging.

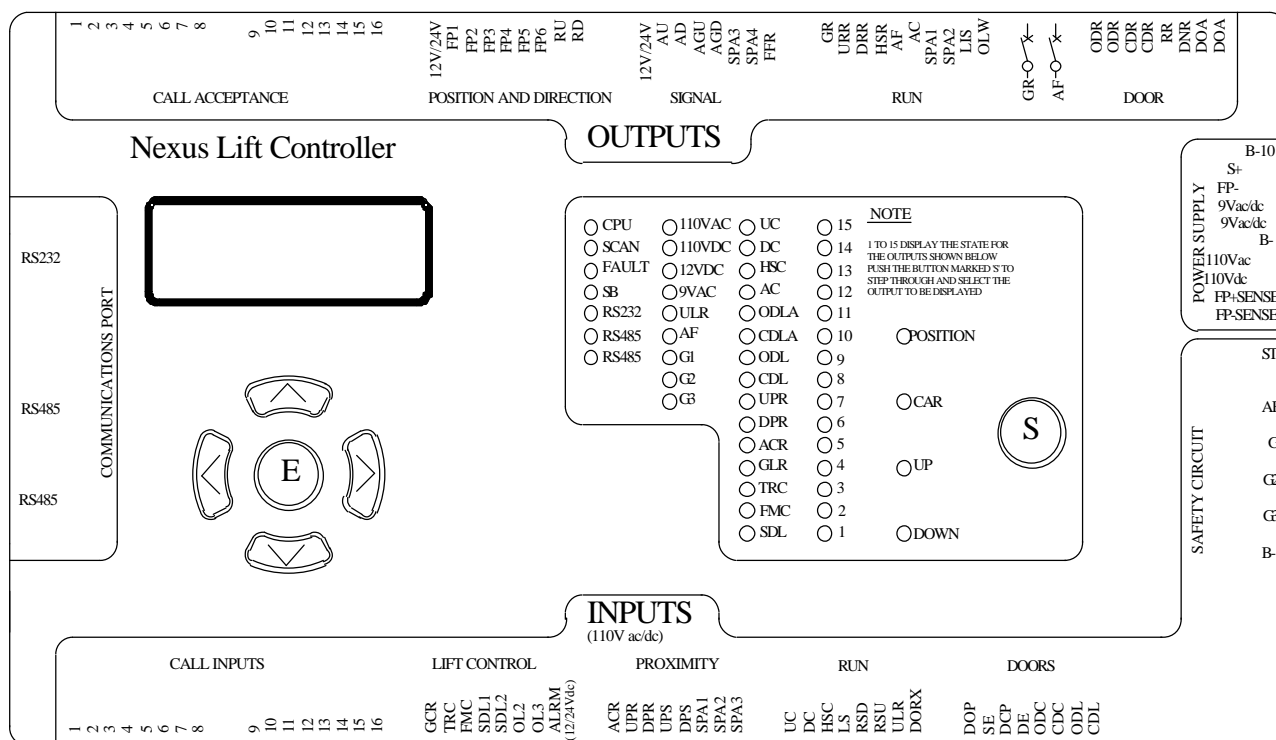

Figure 1.

The programmer/logger is structured using menus, these are used to view the lift status, events, clear the event memory, disable event logging, view the lift starts log, register calls, set and view registers, set the clock, set site and lift number, set programmable parameters and door options.

The menu items are selected by use of the keys <, >. As the keys are pressed or held, the unit will step or scroll through the menus available. Once the required menu is displayed, it can be selected by pressing the key v. When in a menu, the keys ^, v can be used to step up or down the menu or by holding the key, scroll through the menu parameters.

For the menus that allow values to be set, the keys <, > and E are used to select and set the values, the keys <, > are used to select a value or Yes or No and the Key E is used to enter the value. A value or state that is not already programmed into the logger is indicated prefixed by an asterisk (*) or star. If no '* 'symbol is present, then the item is already programmed into memory.

The display format is similar throughout the various menus, an example of which is shown below.

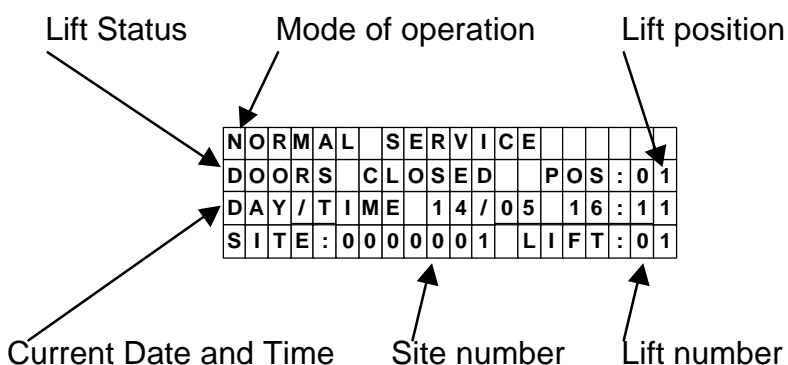

2.9 Dimensions and mounting points.

SEE APPENDIX B FOR TEMPLATE OF MOUNTING POINTS.

3 MANNER OF OPERATION.

The manner of operation of the Nexus Lift Controller is the same as the Generation 1 and 2. If you are familiar with these controllers you will only need to browse through this section.

3.1 Lift Call handling in Normal service.

For the different modes of call handling, the call input and call acceptance are wired in different configurations. For specific information on call wiring see Appendix D.

The call handling is a programmable option, see programming and fault logger interface, section 6. For instructions on how to select required call handling.

3.1.1 Single Button Collective (SBC).

The lift will run to, stop and service any landing calls on the system.

The standard unit can handle up to 8 Floors or with the addition of an expansion board up to 15 floors.

3.1.2 Fully Directional Collective (FDC).

The lift will run to, stop and service any landing calls required in the direction of travel.

The Standard unit can handle up to 6 Floors or with the addition of expansion boards up to 15 floors.

3.1.3 Down call Collective (HCDC).

The lift will run to, stop and service landing calls only in the downward direction. The lift runs up to the highest down call, then collects any calls as it runs down.

The standard unit can handle up to 8 Floors or with the addition of an expansion board up to 15 floors.

3.1.4 Up call collective (LCUC).

The lift will run to, stop and service landing calls only in the upward direction. The lift runs down to the lowest up call, then collects any calls as it runs up.

The standard unit can handle up to 8 Floors or with the addition of an expansion board up to 15 floors.

3.2 Stuck Button.

Any one of the push button inputs will be ignored if it is continuously ON, for more than the programmed stuck button delay time. The range for the delay is from 10 to 60 seconds. The default value is 20 seconds. See section 6 for details on how to adjust this value.

3.3 Call Handling. Out of Normal service.

Landing calls will not be accepted when either the Goods control, Test control, Fire control, Shutdown 1 or 2, Overload 2 or 3 or the over temperature input (SPA1) is active.

Car calls will not be accepted when Test control, Shutdown 1 or 2, Overload 3 or when the Over temperature (SPA1) input is active.

3.4 Lift Travel / Movement and floor level Controls.

See Appendix H for vane dimensions.

The outputs URR, DRR, HSR and AC are used to feed the drive Circuit to the motor circuit and speed control.

URR and DRR: Up Run Relay and Down Run Relay are the low speed run outputs and are active when the lift is in motion in low speed and high speed.

HSR: High speed relay is the High Speed Relay output, when active this output enables the lift to run in high speed.

AC: AntiCreep output will turn ON for re-levelling the lift or for advance door opening. This output is used to enable a lock by pass circuit.

A moving lift car is controlled by the ACR, UPR and DPR inputs. These are grouped together under the inputs labelled PROXIMITY. They indicate the location of a floor and are used in the following manner.

When ACR, UPR and DPR are all ON, the lift is level at a floor.

When the lift is moving in an up direction the first occurrence of a UPR signal, on it's own, will cause the controller to increment the floor position. If there is a call present at the new floor position the lift begins to slow to the floor, HSR is dropped. If there is no call present the lift will remain in high speed and ignore the UPR input when ACR is ON, the lift will increment the floor position at the next occurrence of UPR, on it's own, it will then repeat the cycle as above.

The DPR input, with no ACR input present is ignored when the lift is travelling in an up direction.

The lift will slow to a floor by dropping HSR and running in slow speed until ACR, DPR and UPR are all seen to be ON. The lift will then stop after the programmed **STOP DELAY**, see section 6 for details on how to program this value, and open it's doors, If Advance door open is selected the doors will begin to open when ACR and DPR are ON.

For the lift running in the downward direction, the operation is the same as above, but the lift decrements the position and slows to the floor on the occurrence of the DPR input. UPR on it's own is ignored.

3.5 Operation of floor levelling.

The presence of UPR, DPR and ACR tells the Nexus Lift Controller that the lift car is at floor level and to stop. To enable accurate levelling of the lift car, the controller has a programmable **STOP DELAY**, see section 6 for details. The delay allows for an overlap of UPR and DPR, which means the lift car can drift from floor level by approximately 20mm before the automatic re-levelling occurs. This occurs if the lift is left stationary for a long period of time. Due to the expansion or contraction of the hydraulic oil with temperature change, the lift will slightly rise above or sink below floor level. If safety conditions are met the lift is re-levelled automatically by engaging the anticreep circuit.

3.6 Operation of floor re-levelling (Anticreep).

The UPR and DPR inputs are used to indicate the position of floor level. These inputs are monitored by the Nexus Lift Controller so that the lift can maintain it's floor level. If UPR or DPR are seen to turn OFF the lift will wait the initial re-level programmable delay, before re-levelling. The delay is to allow for passengers to enter the lift, insert a call and hence close the doors and run the lift. Under this condition there is no need to re-level the lift.

The lift will only re-level if the door zone input is valid, ACR energised.

To enable re-levelling, the anticreep (AC) output is turned ON; this by passes the lock circuit and provides a feed to the RUN contactors. There is an electrical interlock that does not allow the by passing of the lock circuit if the lift is not in the door zone, ie, if ACR, UPR or DPR inputs are not present.

There are five programmable options associated with re-levelling. See section 6 for information on these parameters.

3.7 Short Floor Travel.

See appendix I for Short floor vane arrangement.

For short floor travel installations the inputs UPS and DPS are used to indicate the proximity of a short floor.

When the lift is running up it will operate as per normal travel and increment it's floor position on the occurrence of a UPR signal. If there is no requirement to stop and UPS input is ON, the lift will increment the floor position again on the occurrence of UPS, UPR, DPR and ACR. If there is a requirement for the lift to stop, it will slow to the floor when the floor position is incremented.

When the lift is running in the down direction the lift operates as above, but the position decrements on the occurrence of DPS and ACR.

When the lift is running from one short floor to an adjacent short floor, the lift only runs in low speed.

3.8 Floor Reset.

The RSU and RSD inputs can be found on the RUN group of inputs.

The floor reset inputs RSU (Reset Up) and RSD (Reset Down) are used to reset the lift position. When one of the inputs is seen to be ON the current lift position is dropped and replaced with the programmed floor RSU or RSD value. See Section 6 for setting of RSU value.

3.9 Lift Ultimate Limit protection. Fault: ULR.

This can be found on the RUN group of inputs.

Once the Ultimate Limit Input has been energised, the lift will stop immediately, log an ultimate limit fault and latch the lift out of service. The lift can only be returned to normal service once both the fault and latched condition have been cleared.

To clear a latched fault, Push in the reset link on the control panel and cycle the power. A latched fault can also be cleared by use of the logged interface, see section 6 for details.

Caution: The reset link should not be left pushed in, as this will disable the latched faults and could compromise safety.

3.10 Lift Over journey protection. Fault JJT:

Over journey fault conditions are taken care of by an internal, programmable over journey timer. The range of the timer is 60 to 180 seconds. If the lift does not complete the journey within the programmed journey time, the lift will immediately stop and log an over journey fault condition. This is a latched fault and must be cleared before the lift can be put back into service.

To clear a latched fault, Push in the reset link on the control panel and cycle the power. A latched fault can also be cleared by use of the logged interface, see section 6 for details.

Caution: The reset link should not be left pushed in, as this will disable the latched faults and could compromise safety.

3.11 Door Operation.

The Doors will only open when in a valid door zone, this is indicated by the ACR input being ON and the presence of one of the floor level inputs: UPR or DPR.

The door journey time and door open time are programmable parameters. See section 6 for details on how to set these values.

3.12 Advance Door opening.

Advance Door opening is a programmable option. When selected the doors will begin to open on the occurrence of ACR and UPR or DPR. The lift will stop when ACR, UPR and DPR are all ON. To enable advance door opening the anticreep (AC) output is turned ON, this by passes out the lock circuit and provides a feed to the RUN contactors. There is an electrical interlock that does not allow the by passing of the locks if the ACR, UPR or DPR inputs are not present.

3.13 Door controls and Door Nudge.

The door control inputs DOP (Door Open Push), DCP (Door Close Push), SE (Safety Edge) and DORX (Extend Door Open Time), cause the doors to open, close or extend the door open time, see section 4 for detailed descriptions of the inputs operation.

The DNR (Door Nudge) output is a programmable option. This output is used to enable the low torque door drive. If the unit has had door nudging enabled, see section 6 for instructions on setting programmable options. The doors will attempt to nudge close in low torque. Nudging will only occur if the doors have failed to close after the programmed door attempts.

Manner of operation

When Door Nudge is active the photo cell sensor (SE input to the Nexus Lift Controller) is inactive, but the mechanical safety edge is still operational. If the mechanical Safety Edge is activated the doors will stop moving, as long as the Safety Edge is active, once the Safety edge is released the doors will attempt to close (nudge), for the remaining programmed door journey time. When the door journey timer times out the doors will open. The doors will attempt to close again once the door open time has timed out or a car call is input.

3.14 Auxiliary Doors.

The Nexus Lift Controller can be expanded to cater for double door installations by the addition of a plug in expansion board. This board provides the door control inputs and outputs for the auxiliary doors.

Operation of the door and control inputs is the same as for the main doors.

The additional door control inputs and outputs are:

INPUTS

Auxiliary doors safety edge input (SEA),
Auxiliary door enable (DEA),
Auxiliary door open contactor (ODCA)
Auxiliary door close contactor (CDCA)
Auxiliary door open limit (ODLA)
Auxiliary door close limit (CDLA)

OUTPUTS

Auxiliary door open feed (ODRA)
Auxiliary door open output (ODRA)
Auxiliary door close feed (CDRA)
Auxiliary door close output (CDRA)

3.15 Open through car with sequential door opening.

The input DE (Main Door Enable) and the DEA (Auxiliary Door Enable) on the expansion board, are used to identify the door control inputs and which doors to open. The door control signals are fed into a diode matrix to provide the required feed to DE or DEA. A typical circuit is shown in Appendix J.

3.16 Programmable parameters for Main doors and Auxiliary doors.

The parameters for the operation of the doors can be reprogrammed using the in built programming facility. The factory programmed values and ranges, are listed below.

See Section 6 for instruction on how to set these parameters.

NOTE: No prior notice will be given of any changes. It is up to the user to ensure the manual is up to date.

PARAMETER	DEFAULT	RANGE	COMMENT
MND: Manual doors	No	Yes or No	
ADO: Advance doors Open	No	Yes or No	See Door parameters
DJT: Door motion.	10	5 to 15	Seconds.
DOT: Door open time	6	1 to 60	Seconds.
DHT: Door extend open time	20	5 to 30	Seconds.
DDT: Door reverse delay time	0.2	0.1 to 0.9	Seconds
AUX: Auxiliary doors	No	Yes or No	
DJA: Aux door motion	10	5 to 15	Seconds.
DOA: Aux door open	6	1 to 30	Seconds.
DHA: Aux extended open time	10	5 to 60	Seconds.
DDA: Aux reverse delay	0.2	0.1 to 0.9	Seconds.
PFL: Per floor lockout	No	Yes or No	
DNR: Door Nudge	No	Yes or No	
DNO: Door Operation	4	1 to 10	Operations.
CDD: Lock delay	0.5	0.1 to 2	Seconds.
COT: Contact delay	0.5	0.1 to 0.5	Seconds.
CRT: Contact Release Delay	0.5	0.1 to 0.5	Seconds.

3.17 Door programmable options for specific floors.

The '**PROGRAM DOOR OPTIONS**' menu offers the following parameters to enable operation of the doors specific to a floor. See Section 6 for instruction on how to set parameters.

PARAMETER	VALUE	RANGE	COMMENT
DZM: Main Door Zone 1 to 15	Yes	Yes or No	Doors open this floor.
DZA: Aux Door Zone 1 to 15	No	Yes or No	Doors do not open.
DPO: Doors park open.	No	Yes or No	Do not park open.
DPA: Aux Doors park open	No	Yes or No	Do not park open.

4 INPUTS AND FUNCTION

The inputs to the Nexus Lift Controller are grouped together as per function. These groups are: Power Supply, Safety Circuit, Doors, Run, Proximity, Lift control and Call Inputs.

The inputs are situated along the bottom edge and right hand side of the unit and are clearly identified on the label.

Terminal numbering is from left to right, when viewed from end on. That is, Pin 1 is at the left hand end.

A summary list of all the inputs and ratings can be found in Appendix E.

Connection to the unit is via Wago cage clamp plug and socket connectors; these are supplied with the unit.

4.1 Power supply Inputs.

Summary.

FP- SENSE, FP+ SENSE, 110Vdc, 110Vac, B-, 9V ac/dc, FP-, S+, B-10.

FP- and FP+ SENSE Inputs.

12V ac or dc.

FP- and FP+ are used to monitor the 12v dc feed circuit. If no voltage is present a PS3: FP Feed fault will be logged.

110v dc and 110v ac Inputs.

110V ac or dc.

These inputs are used to monitor the 110v dc and 110v ac circuits. If no voltage is present a PS2: 110Vdc or PS1: 110Vac fault will be logged.

The 110Vac input is also used to synchronise the reading of the inputs with the mains cycle. If this input is not present the unit is unable to function.

Both faults will take the lift out of service.

B- Input.

This input is the return point for the 110V dc and 110V ac inputs.

9Vac/dc Inputs.

9V ac or dc.

These are the power supply inputs to the Nexus Lift Controller. The input is protected by an internal resettable fuse. To reset the fuse the power must be cycled.

The 9V supply draws a worst case current of 1.3 Amperes. A transformer winding with a 20 VA rating would provide a suitable power source. This supply

Inputs and function

should not be used to power any other circuits as heavy inductive loads may cause noise problems. This is a precautionary measure rather than a necessity.

FP- and S+ Inputs.

12V ac or dc.

These inputs are used for a 12V dc battery backup input. This provides a supply to enable remote fault reporting when power has failed on the unit. Such as alarm inputs and supply failure fault reports.

B-10 Input.

This input provides a return point for the suppression devices on the unit. This should be run separate to the power source common return.

4.2 Safety Circuit Inputs.

B-, G3, G2, G1, AF, ST.

See Appendix G: Typical key wiring diagram, for details.

ST: Safety Terminal Input.

110V ac or dc.

The ST input monitors the presence of the Safety chain voltage up to the ST point. If no voltage is present a SCF: Safety Circuit fault, will be logged and the lift will not run.

AF: Safety Gear Switch.

110V ac or dc.

The AF input is used to monitor the presence of the safety chain at the AF point. If no voltage is present a 'PS4: AF Signal not present', fault will be logged.

G1: Car Gatelock Relay.

110V ac or dc.

The G1 input monitors the state of the car gate doors: open or closed. When ON the doors are closed and locked. The lift is safe to run, allowing that all other safety inputs are also ON.

For manual doors, G1 is used to monitor the landing beak relay (LBR).

If the G1 input breaks, while the lift is running, the safety chain has been broken and the lift will stop. A GLH: G1 Lock Tripped in High Speed or GLL: G1 Lock Tripped in Low Speed fault will be logged.

If the lock circuit remakes and hence the safety chain, the lift will run when a call is input.

G2: Main Gatelock Relay.**110V ac or dc.**

The G2 input monitors the state of the landing doors: open or closed. When ON, the landing doors are closed and locked. The lift is safe to run, allowing that all other safety inputs are also ON.

For Manual doors, G2 is used to monitor the locking ramp.

If the G2 input breaks, while the Lift is running, the safety chain has been broken and the lift will stop. A GLH: G2 Lock Tripped in High Speed or GLL: G2 Lock Tripped in Low Speed fault will be logged.

If the lock circuit remakes and hence the safety chain, the lift will run when a call is input.

If G2 fails to make when the doors have closed and the programmed **CDD: Lock Delay**, has timed out. The doors will reopen and attempt to close again.

G3: Manual doors car gatelock.

The G3 input monitors the state of the manual doors car gatelock: open or closed. When ON the doors are closed and locked. The lift is safe to run, allowing that other safety inputs are also ON.

If the G3 input breaks, while the Lift is running, the safety chain has been broken and the lift will stop. A GLH: G3 Lock Tripped in High Speed or GLL: G3 Lock Tripped in Low Speed fault will be logged.

If the lock circuit remakes and hence the safety chain, the lift will run when a call is input.

B- Input.

The B- input is the common return point for the of inputs circuits.

This terminal should be wired to the 'B-' rail in the control panel.

4.3 Doors Inputs.

110V ac or dc.

Summary.

DOP, SE, DCP, DE, ODC, CDC, ODL, CDL.

DOP: Door Open Push.

The DOP input will cause the doors to open or remain open under all valid conditions, that is, the Lift is operational and in a door zone.

The DOP input will be ignored if the input is continuously ON for more than the Programmed **stuck button delay time**. See section 6 for details on how to set this value.

SE: Safety Edge.

The SE input is usually wired to the sensitive edge or photocell device.

For a lift in normal service the SE input, when ON, will cause the doors to remain open or if the doors are closing, to reopen the doors.

If the Lift is in a fire mode (FMC = ON), the SE input is ignored.

DCP: Door Close Push.

The DCP input will cause the door to immediately close.

This input is very rarely used, as inserting a car call will also cause the doors to close.

DE: Door Enable. (used for double door installation with per floor lockout)

The DE input is used for double door installations where only one set of doors are allowed to open at any one time. It is used to identify the door controls for the main set of doors. The signal for this input is derived from the door control inputs connected to a diode matrix connected to the DE input. See Appendix J for circuit diagram.

ODC: Open Door Contactor and CDC: Close Door Contactor.

The ODC and CDC inputs are used to confirm that the ODC and CDC contactors have pulled in and that a fault condition has not occurred.

When the output ODR or CDR turns ON, the ODC or CDC input must turn ON before the programmed COT: Contactor delay times out, see section 6 for details on setting this value. If the ODC or CDC input does not turn ON within the delay, the unit will log an ODN: ODC Not Energised or CDN: CDC Not Energised fault will be logged.

ODL: Open Door Limit and CDL: Close Door Limit.

The ODL and CDL inputs are used to determine the state of the doors. These are as follows.

Doors closed:	ODL = ON,	CLD = OFF.
Doors in motion:	ODL = ON,	CDL = ON.
Doors open:	ODL = OFF,	CDL = ON.

4.4 Run Inputs.

110V ac or dc.

Summary.

UC, DC, HSC, LS, RSD, RSU, ULR, DORX.

UC: Up Contactor and DC: Down Contactor.

The UC and DC inputs are used to confirm that the UC and DC contactors have pulled in and that a fault condition has not occurred.

When the output UR or DR turns ON the UC or DC input must turn ON before the programmed COT: Contactor delay times out, see section 6 for details on setting this value.

If the UC or DC input does not turn ON within the delay, The fault URN: UC Not Energised or DRN: DC Not energised will be logged.

If UC or DC fail to pull in, the Lift will cancel all calls. It will attempt to run again only when new calls are entered.

HSC: High Speed Contactor.

The HSC input is used to confirm that the HSC contactor has pulled in and that a fault condition has not occurred.

When the output HSR turns ON, the HSC input must turn ON before the programmed COT: Contactor delay times out, see section 6 for details on setting this value.

Inputs and function

If the HSR input does not turn ON within the delay a HSC: HSC Not Energised fault is logged.

If HSC fails to pull in, all calls will be cancelled and the lift will not attempt to run again unless further calls are entered.

LS: Lag Start.

For installations where there is a limited power supply and the starting current for two lifts at the same time could cause the supply voltage to dip. The LS input can be used to delay the starting of the lift. This input is connected to the 'STAR' starting circuit of the other lift controller and when LS is energised the lift will not run.

RSD: Reset Down and RSU: Reset Up Inputs.

The RSD and RSU inputs are used to reset the current lift car position to the programmed RSD and RSU values. When one of these inputs is ON the current lift car position will be overridden by the RSU or RSD value.

See section section 6 for setting details.

ULR: Ultimate limit input.

The ULR input is fed from a switch operating in conjunction with the ultimate limit switch in the safety chain. When the Ultimate Limit Input has been energised, the lift will stop immediately, log an ultimate limit fault and latch the lift out of service. The lift can only be returned to normal service once both the fault and latched condition have been cleared.

To clear a latched fault, Push in the reset link on the control panel and cycle the power. A latched fault can also be cleared by use of the logged interface, see section 6 for details.

Caution: The reset link should not be left pushed in, as this will disable the latched faults and could compromise safety.

DORX: Door Open Extend time.

This is not a run signal but a door control input but it lives here.

The DORX Input is used to extend the door open time. The range for the extended door open time can be set from 5 to 60 seconds.

This feature is mainly used for installations where, at certain times, the doors are required to stay open longer than normal. Such as, Nursing homes or Hospitals.

4.5 Proximity Inputs.

110V ac or dc.

Summary.

See Appendix H for dimensions of vanes.

ACR, UPR, DPR, UPS, DPS, OVT, LTS, SPA3.

ACR: Door Zone Input.

The ACR input is used to indicate the presence of a valid door opening zone. The doors are unable to open without this input being ON.

UPR: Up Proximity Relay and DPR: Down Proximity Relay.

These inputs are used to increment (UPR) or decrement (DPR) the floor position and to indicate the presence of the floor level (UPR and DPR).

UPS: Up Proximity Short floor and DPS: Down Proximity Short floor

See Appendix I, for short floor vane arrangement.

These inputs are used to indicate the presence of a short floor:

UPS indicates that there is a short floor in the up direction after the next floor.

DPS indicates that there is a short floor in the down direction after the next floor.

OVT (SPA1): Over Temperature Input. (Normally ON).

The Over Temperature input is used to shut the lift down when an over temperature condition occurs with the motor unit. When the input is seen to turn OFF, the lift will attempt to run to the next floor and stop, open it's doors, close it's doors and park with it's doors closed. The doors will reopen to a DOP input. If the lift fails to see a floor level within 20 seconds it will stop and shutdown. A OVT: Over temperature fault condition will be logged.

LTS (SPA2): Latched fault clear switch.

This input is connected to the normally open push/pull 'latched fault' reset link on the control which is fed from 110v ac/dc.

To clear a latched fault, push in the reset link, cycle the power and pull out the reset link.

Caution: LTS reset link must not be left pushed in when lift is in normal operation.

SPA3.

Spare input for future options.

4.6 Lift control Inputs.

Summary.

GCR, TRC, FMC, SDL1, SDL2, OL2, OL3, ALRM.

GCR: Goods Control Relay input.

This is the car preference input, when this input is ON the lift will be under car preference control. The lift will ignore landing calls and park with the doors open. It will only run to one car call at a time.

TRC: Test Control. (Normally ON).

The Nexus Lift Controller is placed in Test Control when this input is OFF. All the RUN and DOOR control outputs are inactive and the lift is controlled by the car top controls. The lift will track the floor position and sound a built in buzzer when the lift passes a floor level. No faults are logged while in test control.

FMC: Fire Control Input.

The FMC input is used to place the lift into the programmed fire mode.

See section 6 for programming information.

This can be fire shutdown or fire control. The two modes comply with the lift directive EN81/2 and are briefly described below.

Operation of FMC input has priority over GCR, SDL1, SDL2 and OL2.

Fire shutdown: When FMC input turns ON, all landing and car calls are cancelled and further call inputs are ignored. The lift will then run to the programmed fire floor, if the lift is running in the opposite direction it will stop at the next floor NOT open the doors and then reverse direction and run to the fire floor. On arriving at the floor the door will open, then, after the door open time, close and park out of service. The doors will reopen to a DOP input or if the FMC input is cycled.

Fire Control: When FMC input turns ON, the lift operates as above but the doors park open at the fire floor. The doors will only close when continuous pressure is applied to a car call button, if the button is released before the doors fully close, the doors will reopen. When the lift runs to a car call, it will run to the call floor, stop and NOT open the doors. The doors will only open to continuous pressure on the DOP button, if this is released before the doors are fully open the doors will re_close. Once the doors are fully open they will park open and only close to continuous pressure on a car call button, as described above.

SDL1(normally ON) and SDL2(normally OFF): ShutDown Lift 1 and 2.

When Shutdown 1 or Shutdown 2 is active, all calls will be cancelled and no further calls will be registered. The lift will run to the programmed shutdown floor, open the doors, close the doors after the door open time and park with the doors closed. The doors will only reopen to a DOP input.

Operation of the Shutdown inputs has priority over GCR and OL2.

OL2 and OL3: Overload 2 and 3.

There are two Overload conditions, overload 2 and overload 3.

Overload 2: The lift will only accept and service car calls. New landing calls will not be accepted.

Overload 3: This input is only effective when the lift is stationary at a floor with the doors open. If OL3 input is energised the lift will remain at floor level with the doors parked open and the OLW output will turn ON, also an overload OLW fault will be logged.

If the overload condition has not been cleared by the time the call cancel timer times out, all calls on the system will be cancelled.

ALRM: Alarm input. (12 to 24V ac/dc).

The Alarm input monitors the Alarm push in the lift car. If the input is energised for more than 3 seconds, an ALR: Alarm Push Operated fault will be logged. The Alarm acknowledge (ALRL (SPA1) Output) will be activated.

4.7 Call Inputs.

The allocation of the call inputs is dependant upon the call handling mode selected. See section 6 for details on selection.

A full list of the call inputs allocations for the different mode of operation can be found in Appendix D. A summary is shown below.

SINGLE BUTTON COLLECTIVE: 8 Floor.

CALL INPUTS

1	2	3	4	5	6	7	8	9	10	11	12	13	14	15	16
C	C	C	C	C	C	C	C	L	L	L	L	L	L	L	L

FULL COLLECTIVE: 6 Floors.

CALL INPUTS

1	2	3	4	5	6	7	8	9	10	11	12	13	14	15	16
C	C	C	C	C	C	U	U	U	U	U	D	D	D	D	D

5 OUTPUTS AND FUNCTION

5.1 Call Acceptance outputs.

The call acceptance outputs voltage source is the 12v/24v input feed on the Position and Direction outputs. Therefore the output voltage is dependent upon the feed voltage.

The call acceptance outputs are current limited and have been designed to drive LED call acceptance illumination. If incandescent lamps are required the control panel will have to be fitted with a relay interface board, Part No: 9300-16.

The allocation of the call acceptance outputs is dependant upon the call handling mode selected. See section 6 for details on program facility.

A full list of the call inputs allocations for the different mode of operation can be found in Appendix D. A summary is shown below.

SINGLE BUTTON COLLECTIVE: 8 Floor.

CALL ACCEPTANCE

1	2	3	4	5	6	7	8		9	10	11	12	13	14	15	16
1	2	3	4	5	6	7	8		1	2	3	4	5	6	7	8
C	C	C	C	C	C	C	C		L	L	L	L	L	L	L	L
L	L	L	L	L	L	L	L		L	L	L	L	L	L	L	L

FULL COLLECTIVE: 6 Floors.

CALL ACCEPTANCE

1	2	3	4	5	6	7	8		9	10	11	12	13	14	15	16
1	2	3	4	5	6	1	2		3	4	5	2	3	4	5	6
C	C	C	C	C	C	U	U		U	U	U	D	D	D	D	D
L	L	L	L	L	L	I	I		I	I	I	I	I	I	I	I

For installations greater than 6 and 8 floors see Appendix D.

5.2 Position and Direction outputs.

Transistor 12 to 24vdc.

The position and direction outputs are fed from the 12v/24 feed input on the same connector. Therefore the output voltage is dependent upon the feed voltage.

The position and direction outputs are current limited and have been designed to drive up to 100mA loads per output. If higher drive currents or incandescent lamps drive are required the control panel will have to be fitted with relay interface board, Part No: 9300-16.

FP1 to FP6: Floor Position.

Transistor 12 to 24vdc

The position outputs are used to indicate the current floor position. The output can be programmed to be One per floor, Binary or Gray code. See section 6 for information on programming of required output.

RU and RD: Run Up and Run Down.

Transistor 12 to 24vdc

The RU and RD outputs are used to indicate the direction of travel of the lift. The relevant outputs will be ON all the time that the lift has a direction of travel and will only turn OFF when the lift has no further calls to answer.

5.3 Signal outputs.

Summary.

AU, AD, AGU, AGD, ALRL, CLT, FFR.

The Signal, LIS and OLW outputs are protected by plug in 1A quick blow fuses. These are mounted on the Main I/O PCB close to the FET devices.

A replacement fuse can be obtained from RS Component part No 417-436 or Farnell Components part No 529-394, The fuse may be removed by simply unplugging the device, a pair of pointed nose pliers may be required for the removal of a fuse.

The outputs are rated for 0.5 A continuous and 1A instantaneous.

AU and AD: Arrival arrows Up and Down.

FET output 12 to 24vdc.

These indicate the intended direction of travel. These outputs are energised whenever there is a direction of travel and the lift is not running in highspeed (HSR = OFF).

AGU and AGD: Arrival Gongs Up and Down.

FET output 12 to 24vdc.

Whenever the lift changes to slow speed to stop at a floor the output AGU or AGD will turn ON for the programmed Gong time duration. Which output turns ON is dependent upon the direction of travel. The output will not turn ON again until the lift stops at another floor.

ALRT (SPA1): Alarm Acknowledge.

FET output 12 to 24vdc.

This output will energise when an input on the alarm input (ALRM). The output is used to acknowledge that the alarm has been reported. This feature will be fully implemented when the unit has been fully developed for remote monitoring.

CLT (SPA2): Car Lighting Control Output.
FET output 12 to 24vdc.

This output is used to control the car lighting and will be energised when the lift is in a door zone with the doors closed and the lift has been inactive for the programmed 'CLT: Lights OFF Delay time'. See section 6 for programming details.

If the Alarm input has been activated the car light output is disabled: The lights will stay ON.

FFR: Fire Fighting Mode Relay.
FET output 12 to 24vdc.

The FFR output will turn ON when the FMC: Fire control input is energised. This output is gated with the Test control Circuit to sound an alarm to warn service personnel that the Fire control has been activated. The lift cannot go into Fire control if on Test control.

5.4 Run outputs.

Summary.

GR, URR, DRR, HSR, AF, AC, ODT (SPA3), CDT (SPA4), LIS, OLW.

The RUN outputs consist of six Relay outputs which are current limit protected by an in built circuit breaker marked as GR –o x , on the label. There are two more outputs marked LIS and OLW, these are FET driven, see section 5.3 for protection information.

GR: Gatelock Relay. (Feed for the run circuit)
FEED INPUT.

The run outputs are fed from the GR input, which is connected to the end of the safety chain. This input is only fed when the lift is safe to run.

URR and DRR: Up Run Relay and Down Run Relay.
Relay contact.

The URR or DRR output turns on when there is a requirement for the lift to run. The output feeds the UR or DR contactor and hence the UC or DC contactor and drive circuit.

If after the programmed contactor delay time (COT), see section 6 for programming details, the UC or DC input to the unit has not been seen to turn ON, the outputs will turn OFF, and Nexus will log a 'URN: UC NOT ENERGISED' or 'DRN: DC NOT ENERGISED' fault. Any calls on the system will be cancelled.

HSR: Highspeed relay.

Relay contact.

The Highspeed relay is energised when the lift is running in high speed and is used in conjunction with URR or DRR outputs to make the drive circuit. As the lift approaches a floor with a requirement to stop, the HSR output will be dropped when the UPR slowing vane is seen. The lift will then run in SLOW speed until ACR, DPR and UPR are seen to be ON.

If after the programmed contactor delay time (COT), see section 6 for programming details, the HSR input to the unit has not been seen to turn ON, the output will turn OFF and Nexus will log a 'HSC: HSC NOT ENERGISED' fault.

AF: Anticreep (levelling) Feed.

Relay contact.

The anticreep (AC) output is fed from the AF input, which is connected to the safety chain prior to the lock circuit. This input is only fed when the lift is in the door zone and safe to run.

AC: Anticreep (levelling) output.

Relay contact.

The AC output is energised for re-levelling the lift or for advance door opening. The output is used to enable the lock by pass circuit. See Appendix G for Typical wiring diagram.

ODT (SPA3): Doors opening speech trigger output.

Relay contact.

ODT will trigger a Speech unit 'Doors opening' phrase, if fitted. This occurs when ACR and UPR or DPR turns ON.

CDT (SPA4): Doors closing speech trigger output.

Relay contact.

CDT will turn ON to trigger the 'Door close' phrase, 3 seconds before the doors attempt to close, this is to enable passengers to move away from the doors.

LIS: Lift in Service.

FET output 12 to 24vdc.

The LIS output will be energised the whole time that the lift is in normal service. The output will turn OFF, when any of the control inputs are active or if an out of service fault condition has been detected.

OLW: Overload Warning.

FET output 12 to 24vdc.

The overload warning output will be energised when an overload level 3 condition is detected, OL3 input ON.

5.5 Door outputs.

ODR and CDR: Open Door Relay and Close Door Relay.

Volt free contact for opening and closing lift doors. The ODR or CDR is energised to open or close the doors when the lift is in a valid door zone and there is a command to open or close the doors.

When the ODR or CDR outputs are energised the unit waits the programmed 'COT: contactor delay time', for the ODC or CDC input to turn ON, if these inputs fail to turn ON before the delay time a 'ODN: ODC NOT ENERGISED' or 'CDC NOT ENERGISED' fault will be logged. See section 6 if programming of contactor delay time.

RR: Retiring ramp.

Relay contact.

For Manual doors this output is energised to lock the Landing doors when the lift is in motion or when the car door is closing.

DNR: Door Nudge Relay.

Relay contact.

For installations where the door control has a low torque facility, this output can be used to try to nudge the obstruction and attempt to close the doors. When Door Nudge is active the photo cell sensor (SE input) is inactive, but the mechanical safety edge is still operational. If the mechanical Safety Edge is activated the doors will stop moving, as long as the Safety Edge is active, once the Safety edge is released the doors will attempt to close (nudge), for the remaining programmed door journey time. When the door journey timer times out, the doors will open and cancel all calls. The doors will attempt to close again once the door open time has timed out or a car call is input.

DOA: Door Open Alarm.

Relay Contact.

This is a volt free contact for sounding an alarm if the doors are left open. This is used in manual door installations.

6 PROGRAMMING AND FAULT LOGGING.

6.1 Introduction.

Note: It is not possible to program any of the parameters without the electronic key plugged into the RS232 port.

The Nexus Lift Controller incorporates a built in logger facility for logging lift status, events and programmable information.

The logger consists of a liquid crystal display (LCD) and 5 keys marked \wedge , \vee , $>$, $<$ and E. See Figure 1, for layout of front panel. The LCD is used for displaying lift status, events and programmable information. The keys are used to step through menu options and programming parameters.

The programmer / logger interface is via a list of menus which are accessed using the keys $>$, $<$. The menu options are shown below.

Lift Status \Leftrightarrow View Lift events \Leftrightarrow Clear event log \Leftrightarrow Event options \Leftrightarrow Lift starts log \Leftrightarrow Register calls \Leftrightarrow Set and view registers \Leftrightarrow Set current date and time \Leftrightarrow Set Site No \Leftrightarrow Program Facility \Leftrightarrow Program door options \Leftrightarrow return to Lift Status.

See Appendix K for menu details.

6.2 Description of Operation.

The interface to the programmer and logger functions is via 11 menus. The menus are made up of a list of items relevant to the menu name, as listed above.

The menu list is stepped through using the keys $<$, $>$. As the menus are stepped through, each option is displayed on the LCD. When the last menu is reached, the menu will wrap around to the first option.

To access a menu, press the key $>$ until the display shows the required menu. Press the key \vee , to enter into the menu. If the key $>$ has no effect, you are already in a menu and must return to the main menu selection. This is done by pressing the key \wedge , until the display offers you the option 'To Exit Press $<$ or $>$ ', pressing either of these keys will return you to the main menu. You should then be able to step through the menu as described above.

To select a particular menu option, use the keys \vee , \wedge . These keys enable a user to run up and down the menu items. For details of each menu item see Appendix K for a list of menu items.

Programming and fault logging

The menu items can be stepped through by repeatedly pressing the keys \wedge or \vee . To scroll through the menu hold the key down.

To set a programmable value use the keys \leftarrow , \rightarrow and E. This is done by stepping through the selection of values and pushing the key E, to enter the option YES/NO or the selected value, depending on the selection offered.

Programmable values **that are not** programmed into the unit are prefixed by an asterisk '*' symbol next to the value. Once the value has been programmed into memory no asterisk '*' symbol will be next to the value.

6.3 Lift Status.

This is the default and is displayed after power up. The display shows information on the lift mode of operation and status, such as: Normal service, doors closed or Goods control ON, doors open. The floor position and current date and time are also displayed with the message.

Examples of the lift message are:

Normal service: Lift is operating in normal service and working.

Out of service: The lift has a fault that has stopped it from working.

See Appendix K for a full list and explanation of messages.

Example of Status display format.

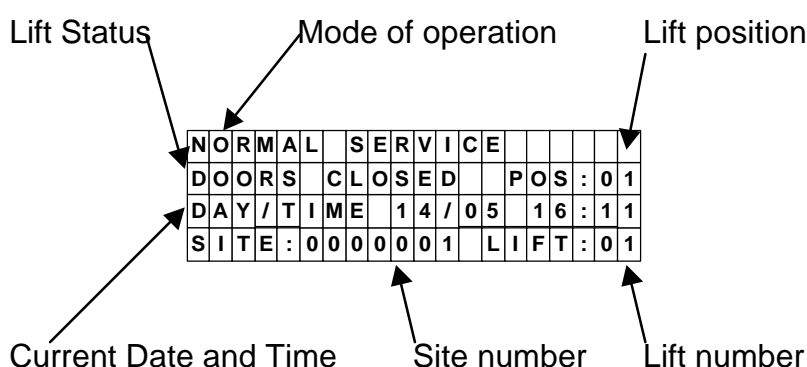

6.4 Lift Event Table.

The Nexus Lift Controller records all events or faults that effect the lift's performance. To view the event log menu the key >, should be pressed until the LCD reads as 'View Lift Events'. The key v, should then be pressed to enter into the event log. Once in the event log the keys v and ^ are used to step up and down the event log. Holding the key will scroll the menu.

Up to 30 faults are logged with the previous 10 lift operations leading up to the fault. These are accessed by pushing the keys < or >, to step through the operations. Once the last operation is displayed the message wraps round to the event/fault message.

Faults are logged with the date, time, floor position and the amount of times the fault has occurred. For subsequent repeats of the same fault only the occurrence will be incremented. The same fault will only be logged again if the floor position has changed or another type of fault has occurred.

A full list of Event\Fault messages can be found in Appendix L.

Example of Event/Fault message.

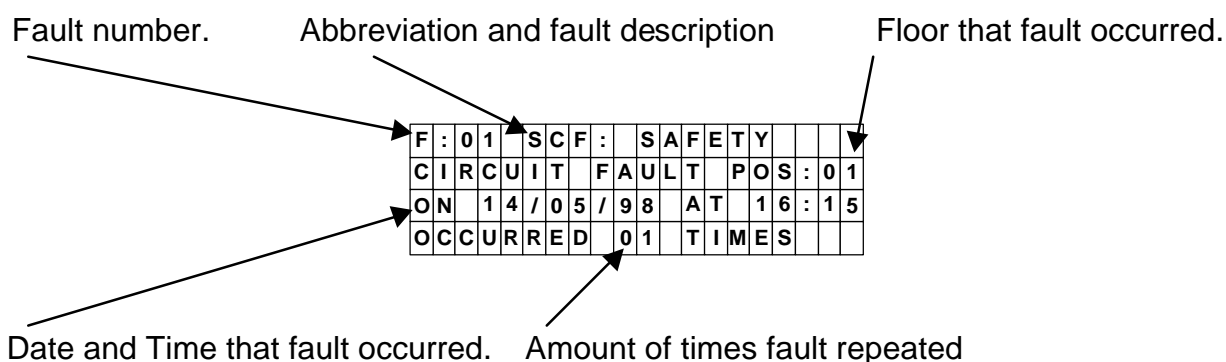

6.5 Clearing Event table.

It is only possible to clear the event log if the electronic key is plugged into the RS232 communication port.

To clear the event/fault log press the key >, until the display reads as 'Clear Event Log'. Press key v, to enter clear event menu.

The messages 'Clear Event Log ?ON' and 'Are you sure?' 'press E to clear' will be displayed. Press the key E, to clear the event log or keys <, >, ^ or v to exit without clearing the event log. If you press the key E, the message 'Event log cleared' or 'Event log will be cleared when lift stops' will be displayed. To exit the clear event log menu press keys < or >.

6.6 Event Option.

Event options allows for the logging of a fault condition to be disabled by selection of YES to log a fault or NO **not to** log a fault, the default is YES. The option **that is not** programmed into the unit is prefixed by an asterisk '*' symbol next to the option. Once the choice has been programmed into memory no asterisk '*' symbol will appear next to the value.

To access the Event Options menu, press the key > until the display reads as 'Event Option'. Press the key v, to enter into the menu. Use the keys ^ or v to step through the event option list, holding the key will scroll the menu.

To enable or disable an event from being logged, select the event, then select YES to log the fault or NO to disable logging of the fault. Then use the key E, to enter the selection.

The event option list is the same as the event fault log list, See Appendix L, for details.

6.7 Lift Starts Log.

The start log records the number of 'Normal Starts' and 'Re-level starts'. The display shows the number of starts in the last 15 minutes and the maximum number of starts within a 15 minute period.

To access the Lift Starts log menu, press the key > until the display reads as 'Lift Starts Log'. Press key v, to enter into the menu.

Firstly, the Normal starts will be displayed, press key v to display re-level starts.

To clear the starts log press the key v until the display reads as 'Lift Starts Log, Clear Max Starts'. Press key E, to clear the log. The display will then read as 'Max Starts Cleared'. Press key < or > to exit. The starts log should be zero. To exit without clearing the log Press keys <, >, ^ or v.

Example of Starts log message.

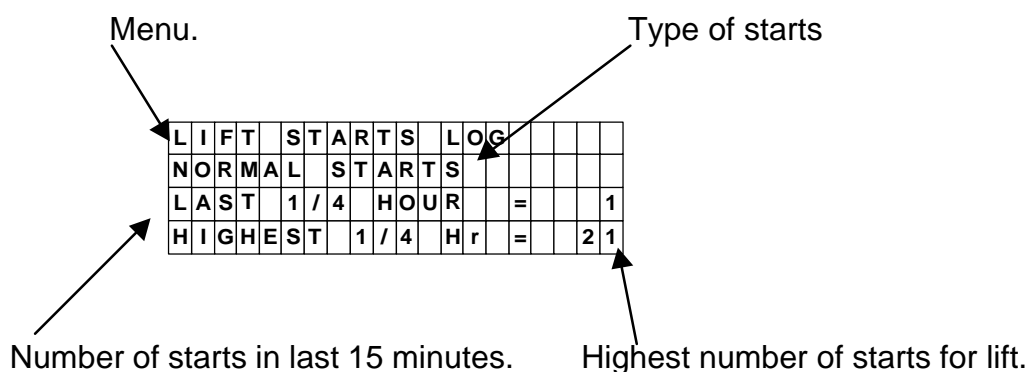

6.8 Register Calls.

It is only possible to enter calls if the Lift is in Normal Service. If the lift is in car preference or any other control input is active, the calls will be ignored.

To access the Register calls menu use the key >, until the display reads as 'Register Calls'. To enter in to the menu press key √.

The Register call menu allows the engineer to enable automatic call insertion to terminal floors by setting 'Test Cycle Lift' to ON, using the keys < or > to select ON or OFF. **It is only possible to set the lift to cycle test if the electronic key is plugged into the RS232 port.**

To manually insert a call use the keys √ or ^, to step up and down the call table, until the desired floor is selected. Then use the keys < or > to select YES or NO. Once all the required calls have been selected press the key E, to enter the calls. The call pattern entered, is maintained until it is cleared by the user.

6.9 Set and View Registers.

It is only possible to set event options if the electronic key is plugged into the RS232 communications port.

The Set and View register option cannot override the inputs to the Nexus Lift Controller. Therefore, if the Car Preference input is ON, it is not possible to turn it OFF from the menu option.

The Set and View Register menu allows the engineer to view the state of the inputs, outputs and to set some of the control inputs, such as, Car preference, Firecontrol, Door open and Door close. A full list of the menu options can be found in Appendix M.

To access the Set and View Options menu, press the key > until the display reads as 'Set / View Registers'. Press key √, to enter into the menu.

Use the keys ^, √ to step through the Set and View Register options.
To select an option used the keys < or >. Press key E to enter a selected option.

6.10 Clock Setting.

It is not possible to set the current date and time unless the electronic key is plugged into the RS232 Communication port.

The internal clock will automatically update from winter to summer time on the 31st day of October and March, respectively. If the unit is not powered on these dates it will be necessary to update the clock manually.

This is achieved by selecting the set current time/date menu, by pressing the key >, until the display reads as, 'Set Current Time/Day'. Press key √, to enter into the menu.

The internal clock is set using this menu. Use the key √ or ^ to select the required digit. The keys < and > are used to decrease or increase the value selected. Once the required date and time have been set, press the key E, to enter the time. The internal clock will be updated at this time. To exit, press the keys √ or ^ until the exit message is displayed, then press keys < or > to exit.

6.11 Setting Site.

It is not possible to set the site number unless the electronic key is plugged into the RS232 Communication port.

To set the site number, press the key > until the display reads as 'Set Site Number '. Press the key √, to enter into the menu.

The site number can be set using this menu. Use the key √ or ^ to select the required digit. The keys < and > are used to decrease or increase the value selected. Once the required numbers have been set, press the key E, to enter the number. The Site Number will be updated at this time. To exit, press the keys √ or ^ until the exit message is displayed, then press keys < or > to exit.

A non programmed value is prefixed by an asterisk '*' (star) symbol.

6.12 Programmable Options.

It is only possible to set programmable parameters if the electronic key is plugged into the RS232 communications port.

The program facility allows for on site programming of up to 58 lift parameters, a full list of the programmable parameters can be found in Appendix N.

A parameter **that is not** programmed into the unit is prefixed by an asterisk '*' symbol next to it. Once the choice has been programmed into memory the asterisk '*' will disappear.

To access the program facility menu, press the key > until the display reads as ' Program Facility'. Press the key √, to enter into the menu.

To view the programmable parameters use the keys ^ and v to step up and down the menu, holding the key will scroll the menu. To set a value or option use the keys < or > to decrease or increase the value or select YES or NO. To enter a value press key E.

The first few messages to be displayed are for information only and cannot be edited in this menu. These are: Site number, Program type, and Version.

Example of Program Facility message.

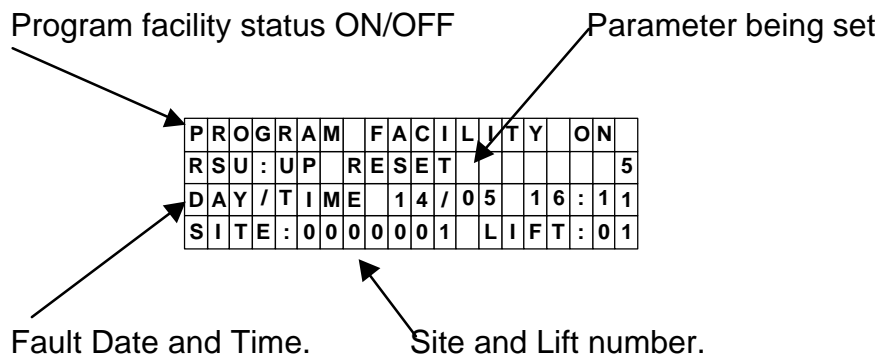

6.13 Programmable Door Options.

It is only possible to set Programmable Door Options if the electronic key is plugged into the RS232 communications port.

The manner in which the doors operate for one or two sets of doors can be specified with this menu. The operation that can be specified is for a given floor. These are floors where the doors are allowed to open (door zones) and where the doors can park open, for main and auxiliary doors. Up to 15 floor can be programmed. See section 3.17 for a list of the parameters.

Programming and fault logging

A parameter **that is not** programmed into the unit is prefixed by an asterisk '*' symbol next to it. Once the choice has been programmed into memory no asterisk '*' symbol will appear next to the option.

To access the Door Options menu, press the key > until the display reads as 'Program Door Opt'. Press the key √, to enter into the menu.

To view the door options use the keys ^ and v to step up and down the menu, holding the key will scroll the menu.

To set an option, use the keys < or > to select YES or NO.

To enter a value press key E.

APPENDIX A: TECHNICAL SPECIFICATION

TECHNICAL SPECIFICATION

DIMENSIONS	404 x 200 x 128mm. (159 x 78 x 50.5 inches) – 2.025Kg (4lb 8oz)
WEIGHT	2.025 Kg (4lb 8oz)
COLOUR	Grey
POWER SUPPLY	9 V ac or dc, 1.3 Amperes. (20 VA Transformer winding)
INPUT CIRCUITS	Typically 110 V ac or dc, 1.4 A.
	For Alarm 12/24V , 1.2/2.4 mA
OUTPUT CIRCUITS	Run and Door 110 V ac or dc, Current limit 1 A
	Signal 12/24 V dc (unsmoothed), 0.5 A continuous, 1 A instantaneous
	Call and position 12/24 V (smoothed), 0.3 A.
ENVIRONMENT	Operating ambient Temperature: 0 to +40 °C.
	Storage ambient Temperature: -10 to + 70 °C
	Humidity ambient: Manufactured to customer requirements. Please specify.
STANDARDS	Operation complies to Lift Directive EN 81/2 1998.
	EMC Emissions comply to EN 12015.
	EMC Immunity complies to EN 12016.
<p>Specifications are subject to change without prior notification.</p> <p>© Stannah Lifts Ltd 1999 – ALL RIGHTS RESERVED.</p> <p>Stannah Lifts Ltd, Anton Mill, Andover, Hampshire, SP10 2NX, England. Tel: (01264) 339090. Fax: (01264) 337942. Email: stannah.co.uk.</p>	

APPENDIX B: NEXUS SPECIFICATION

INSERT TEMPLATE FOR MOUNTING POINTS

APPENDIX C: NEXUS FRONT PANEL ABBREVIATIONS

NEXUS STATUS LEDS

CPU	Microprocessor running ok.
SCAN	Inputs are being scanned and 110vac input present
FAULT	A fault is present on the system
SB	Stuck button on system
RS232	RS232 communication port active
RS485	RS485 communications port active
RS485	RS485 communications port active

POWER AND SAFETY CHAIN

110VAC	Indication that 110 volts AC is present.
110VDC	Indication that 110 volts DC is present.
12VDC	Indication that 12 volts DC is present.
9VAC	Indication that 9 volts AC is present.
ULR	Ultimate Limit fault, when led ON.
AF	Anticreep Feed signal is present in safety chain
G1	Gatelock for door close
G2	Gatelock for door close
G3	Gatelock for door close

LIFT CONTROL INPUTS

UC	When ON, Up run contactor input energised.
DC	When ON, Down run contactor input energised
HSC	When ON, High speed contactor input energised
AC	When ON, Anticreep output energised
ODL	When ON, Main doors are closed
CDL	When ON, Main doors are open
ODLA	When ON, Aux doors are closed
CDLA	When ON, Aux doors are open
UPR	Up proximity vane input ON
DPR	Down proximity vane input ON
ACR	Door zone vane input ON
GCR	Goods control input ON
TRC	Test control input active ON
FMC	Fire control input ON
SDL	Shutdown 1 or 2 ON

CALL AND POSITION INPUTS

1 to 15	Leds used to show lift position and call acceptance for Car, up and down landing buttons. Depending on selection using S button on label.
---------	---

APPENDIX D: Call input and acceptance wiring.

Terminal allocations

The wiring of the call inputs and call acceptance outputs is dependant upon the programmed call handling for the Lift installation. Listed below are the terminal allocations for each configuration.

NOTE: Terminals are numbered from left to right, pin 1 at left most end, when unit viewed from side on.

SINGLE BUTTON COLLECTIVE: MAIN I/O BOARD WIRING INFORMATION.

CALL ACCEPTANCE

1	2	3	4	5	6	7	8		9	10	11	12	13	14	15	16
1	2	3	4	5	6	7	8		1	2	3	4	5	6	7	8
C	C	C	C	C	C	C	C		L	L	L	L	L	L	L	L
L	L	L	L	L	L	L	L		L	L	L	L	L	L	L	L

CALL INPUTS

1	2	3	4	5	6	7	8		9	10	11	12	13	14	15	16
1	2	3	4	5	6	7	8		1	2	3	4	5	6	7	7
C	C	C	C	C	C	C	C		L	L	L	L	L	L	L	L

FULL COLLECTIVE: MAIN I/O BOARD WIRING INFORMATION.

CALL ACCEPTANCE

1	2	3	4	5	6	7	8		9	10	11	12	13	14	15	16
1	2	3	4	5	6	1	2		3	4	5	2	3	4	5	6
C	C	C	C	C	C	U	U		U	U	U	D	D	D	D	D
L	L	L	L	L	L	I	I		I	I	I	I	I	I	I	I

CALL INPUTS

1	2	3	4	5	6	7	8		9	10	11	12	13	14	15	16
1	2	3	4	5	6	1	2		3	4	5	2	3	4	5	6
C	C	C	C	C	C	U	U		U	U	U	D	D	D	D	D

APPENDIX D: Call input and acceptance wiring.

NOTE: Terminals are numbered from left to right, pin 1 at left most end, when unit viewed from side on.

SINGLE BUTTON COLLECTIVE: EXPANSION BOARD WIRING INFORMATION.

CALL ACCEPTANCE

1	2	3	4	5	6	7	8		9	10	11	12	13	14	15	16
9	10	11	12	13	14	15	16		9	10	11	12	13	14	15	16
C	C	C	C	C	C	C	C		L	L	L	L	L	L	L	L
L	L	L	L	L	L	L	L		L	L	L	L	L	L	L	L

CALL INPUTS

1	2	3	4	5	6	7	8		9	10	11	12	13	14	15	16
9	10	11	12	13	14	15	16		9	10	11	12	13	14	15	16
C	C	C	C	C	C	C	C		L	L	L	L	L	L	L	L

FULL COLLECTIVE: EXPANSION BOARD WIRING INFORMATION.

CALL ACCEPTANCE

1	2	3	4	5	6	7	8		9	10	11	12	13	14	15	16
9	10	11	12	13		6	7		8	9	10	7	8	9	10	11
C	C	C	C	C		U	U		U	U	U	D	D	D	D	D
L	L	L	L	L		I	I		I	I	I	I	I	I	I	I

CALL INPUTS

1	2	3	4	5	6	7	8		9	10	11	12	13	14	15	16
9	10	11	12	13		6	7		8	9	10	7	8	9	10	11
C	C	C	C	C		U	U		U	U	U	D	D	D	D	D

Notes: For second expansion board, terminal allocation is the same but floor numbers are for 12 to 16.

C denotes car calls and acceptance illumination.

L or I Denotes landing calls and acceptance illumination.

U denotes up landing calls and acceptance illumination.

D denotes down landing calls and acceptance illumination.

APPENDIX E: Input ratings and description.

NOTE: Terminals are numbered from left to right, pin 1 at left most end, when unit viewed from side on.

MAIN I/O BOARD

ALL INPUTS FOR SINGLE BUTTON COLLECTIVE.

No	INPUT	DESCRIPTION	VOLTAGE	NOTES
1	1	Car Call input floor 1	110v ac/dc	Single Button operation
2	2	Car Call input floor 2	110v ac/dc	
3	3	Car Call input floor 3	110v ac/dc	
4	4	Car Call input floor 4	110v ac/dc	
5	5	Car Call input floor 5	110v ac/dc	
6	6	Car Call input floor 6	110v ac/dc	
7	7	Car Call input floor 7	110v ac/dc	
8	8	Car Call input floor 8	110v ac/dc	
1	9	Landing call input 1	110v ac/dc	Single Button operation
2	10	Landing call input 2	110v ac/dc	
3	11	Landing call input 3	110v ac/dc	
4	12	Landing call input 4	110v ac/dc	
5	13	Landing call input 5	110v ac/dc	
6	14	Landing call input 6	110v ac/dc	
7	15	Landing call input 7	110v ac/dc	
8	16	Landing call input 8	110v ac/dc	

EXPANSION I/O BOARD (If Fitted)

CALL INPUTS FOR SINGLE BUTTON COLLECTIVE.

No	INPUT	DESCRIPTION	VOLTAGE	NOTES
1	1	Car Call input floor 9	110v ac/dc	Single Button operation
2	2	Car Call input floor 10	110v ac/dc	
3	3	Car Call input floor 11	110v ac/dc	
4	4	Car Call input floor 12	110v ac/dc	
5	5	Car Call input floor 13	110v ac/dc	
6	6	Car Call input floor 14	110v ac/dc	
7	7	Car Call input floor 15	110v ac/dc	
8	8			
1	9	Landing call input 9	110v ac/dc	Single Button operation
2	10	Landing call input 10	110v ac/dc	
3	11	Landing call input 11	110v ac/dc	
4	12	Landing call input 12	110v ac/dc	
5	13	Landing call input 13	110v ac/dc	
6	14	Landing call input 14	110v ac/dc	
7	15	Landing call input 15	110v ac/dc	
8	16			

APPENDIX E: Input ratings and description.

MAIN I/O BOARD

CALL INPUTS FOR FULL COLLECTIVE.

No	INPUT	DESCRIPTION	VOLTAGE	NOTES
1	1	Car Call input for floor 1	110v ac/dc	Full collective operation
2	2	Car Call input for floor 2	110v ac/dc	
3	3	Car Call input for floor 3	110v ac/dc	
4	4	Car Call input for floor 4	110v ac/dc	
5	5	Car Call input for floor 5	110v ac/dc	
6	6	Car Call input for floor 6	110v ac/dc	
7	7	Landing UP input 1	110v ac/dc	
8	8	Landing UP input 2	110v ac/dc	
1	9	Landing UP input 3	110v ac/dc	Full collective operation
2	10	Landing UP input 4	110v ac/dc	
3	11	Landing UP input 5	110v ac/dc	
4	12	Landing DOWN input 2	110v ac/dc	
5	13	Landing DOWN input 3	110v ac/dc	
6	14	Landing DOWN input 4	110v ac/dc	
7	15	Landing DOWN input 5	110v ac/dc	
8	16	Landing DOWN input 6	110v ac/dc	

EXPANSION I/O BOARD (If Fitted)

CALL INPUTS FOR FULL COLLECTIVE.

No	INPUT	DESCRIPTION	VOLTAGE	NOTES
1	1	Car Call input floor 7	110v ac/dc	Full collective operation
2	2	Car Call input floor 8	110v ac/dc	
3	3	Car Call input floor 9	110v ac/dc	
4	4	Car Call input floor 10	110v ac/dc	
5	5	Car Call input floor 11	110v ac/dc	
6	6			Not used.
7	7	Landing UP input 6	110v ac/dc	
8	8	Landing UP input 7	110v ac/dc	
1	9	Landing UP input 8	110v ac/dc	Full collective operation
2	10	Landing UP input 9	110v ac/dc	
3	11	Landing UP input 10	110v ac/dc	
4	12	Landing Down input 7	110v ac/dc	
5	13	Landing Down input 8	110v ac/dc	
6	14	Landing Down input 9	110v ac/dc	
7	15	Landing Down input 10	110v ac/dc	
8	16	Landing Down input 11	110v ac/dc	

NOTE: For second Expansion board, terminal allocation is the same but floor numbers are for 12 to 16

APPENDIX E: Input ratings and description.

LIFT CONTROL INPUTS.

No	INPUT	DESCRIPTION	VOLTAGE	NOTES
1	GCR	Goods Control	110v ac/dc	
2	TRC	Test Control Input	110v ac/dc	
3	FMC	Fire Control Input	110v ac/dc	Home to Fire Floor
4	SDL1	Shutdown Lift 1	110v ac/dc	Home to Shutdown 1 Floor
5	SDL2	Shutdown Lift 2	110v ac/dc	Home to Shutdown 2 Floor
6	OL2	Overload Warning 2	110v ac/dc	Bypass Landing calls
7	OL3	Overload Warning 3	110v ac/dc	Does not shut doors or run
8	ALRM	Alarm Input	12v ac/dc	Monitor for Alarm button

LIFT PROXIMITY INPUTS.

No	INPUT	DESCRIPTION	VOLTAGE	NOTES
1	ACR	Door Zone	110v ac/dc	Doors can open.
2	UPR	Up Proximity Relay	110v ac/dc	Up position sequencing
3	DPR	Down Proximity Relay	110v ac/dc	Down position sequencing
4	UPS	Up Short Floor Travel	110v ac/dc	Up travel short floor
5	DPS	Down Short Floor Travel	110v ac/dc	Down travel short floor
6	OVT	Over Temperature input	110v ac/dc	Motor over temp input
7	LTS	Spare Input	110v ac/dc	Clear latch fault input
8	SPA3	Spare Input	110v ac/dc	Not used

RUN, LIMITS AND DOOR EXTENSION INPUTS.

No	INPUT	DESCRIPTION	VOLTAGE	NOTES
1	UC	Up Contactor	110v ac/dc	
2	DC	Down Contactor	110v ac/dc	
3	HSC	High Speed Contact	110v ac/dc	
4	LS	Lag start	110v ac/dc	Used to delay start of lift.
5	RSD	Reset Bottom	110v ac/dc	
6	RSU	Reset Top	110v ac/dc	
7	ULR	Ultimate Limit Relay		
8	DORX	Door Extension	110v ac/dc	

DOOR CONTROL INPUTS.

No	INPUT	DESCRIPTION	VOLTAGE	NOTES
1	DOP	Door Open Pushbutton	110v ac/dc	
2	SE	Safety edge	110v ac/dc	
3	DCP	Door Close Pushbutton	110v ac/dc	
4	DE	Main Door Enable	110v ac/dc	
5	ODC	Door Open Contactor	110v ac/dc	
6	CDC	Door Close Contactor	110v ac/dc	
7	ODL	Door Open Limit	110v ac/dc	
8	C DL	Door Close Limit	110v ac/dc	

APPENDIX E: Input ratings and description.

SAFETY CIRCUIT INPUTS.

No	INPUT	DESCRIPTION	VOLTAGE	NOTES
1				
2				
3				
4	B-	Common Return	110v ac/dc	
5				
6	G3			Manual Doors Car Gate
7				
8	G2	Main Gate Lock relay	110v ac/dc	Manual Doors Lock Ramp
9				
10	G1	Car Gate Relay	110v ac/dc	Manual Doors LBR
11				
12	AF	Safety Gear Switch	110v ac/dc	

POWER SUPPLY INPUTS.

No	INPUT	DESCRIPTION	VOLTAGE	NOTES
1	ST	SAFETY TERMINAL	110v ac/dc	Caution safety chain cable
2				
3	FP-SENSE	12v Common Return		
4	FP+SENSE	12v Supply Monitor	12v dc Feed	Connect to fused supply
5	110Vdc	110v dc Supply Monitor	110v dc	Connect to fused supply
6	110Vac	110v ac Supply Monitor	110v ac	Connect to fused supply
7	B-	Common Return		
8	9Vac/dc	Nexus Power Supply	9v ac/dc	Only connect 9v to Nexus
9	9Vac/dc	Nexus Power Supply	9v ac/dc	
10	FP-	Battery Return		Connect to battery backup
11	S+	Battery Feed	12v dc	Connect to battery backup
12	B-10	Varistor Return		Connect direct to B-

EXPANSION BOARD AUXILIARY DOOR CONTROL INPUTS.

No	INPUT	DESCRIPTION	VOLTAGE	NOTES
1	SEA	Aux Safety Edge input	110v ac/dc	
2	DEA	Aux door enable	110v ac/dc	
3	ODCA	Aux door open contactor	110v ac/dc	
4	CDCA	Aux door close contactor	110v ac/dc	
5	ODLA	Aux open door limit	110v ac/dc	
6	CDLA	Aux close door limit	110v ac/dc	
7	SPA4	Spare input	110v ac/dc	
8	SPA5	Spare input	110v ac/dc	

APPENDIX F: Output ratings and description.

NOTE: Terminals are numbered from left to right, pin 1 at left most end, when unit viewed from side on.

MAIN I/O BOARD

CALL ACCEPTANCE OUTPUTS FOR SINGLE BUTTON COLLECTIVE.

No	OUTPUT	DESCRIPTION	VOLTAGE	NOTES
1	1	Car Call acceptance 1	12v/24vdc	Single Button operation
2	2	Car Call acceptance 2	12v/24vdc	
3	3	Car Call acceptance 3	12v/24vdc	
4	4	Car Call acceptance 4	12v/24vdc	
5	5	Car Call acceptance 5	12v/24vdc	
6	6	Car Call acceptance 6	12v/24vdc	
7	7	Car Call acceptance 7	12v/24vdc	
8	8	Car Call acceptance 8	12v/24vdc	
1	9	Landing call acceptance 1	12v/24vdc	Single Button operation
2	10	Landing call acceptance 2	12v/24vdc	
3	11	Landing call acceptance 3	12v/24vdc	
4	12	Landing call acceptance 4	12v/24vdc	
5	13	Landing call acceptance 5	12v/24vdc	
6	14	Landing call acceptance 6	12v/24vdc	
7	15	Landing call acceptance 7	12v/24vdc	
8	16	Landing call acceptance 8	12v/24vdc	

EXPANSION I/O BOARD (If Fitted)

CALL INPUTS FOR SINGLE BUTTON COLLECTIVE.

No	OUTPUT	DESCRIPTION	VOLTAGE	NOTES
1	1	Car Call acceptance 9	12v/24vdc	Single Button operation
2	2	Car Call acceptance 10	12v/24vdc	
3	3	Car Call acceptance 11	12v/24vdc	
4	4	Car Call acceptance 12	12v/24vdc	
5	5	Car Call acceptance 13	12v/24vdc	
6	6	Car Call acceptance 14	12v/24vdc	
7	7	Car Call acceptance 15	12v/24vdc	
8	8			
1	9	Landing call acceptance 9	12v/24vdc	Single Button operation
2	10	Landing call acceptance 10	12v/24vdc	
3	11	Landing call acceptance 11	12v/24vdc	
4	12	Landing call acceptance 12	12v/24vdc	
5	13	Landing call acceptance 13	12v/24vdc	
6	14	Landing call acceptance 14	12v/24vdc	
7	15	Landing call acceptance 15	12v/24vdc	
8	16			

APPENDIX F: Output ratings and description.

MAIN I/O BOARD

CALL INPUTS FOR FULL COLLECTIVE.

No	OUTPUT	DESCRIPTION	VOLTAGE	NOTES
1	1	Car Call acceptance 1	12v/24vdc	Full collective operation
2	2	Car Call acceptance 2	12v/24vdc	
3	3	Car Call acceptance 3	12v/24vdc	
4	4	Car Call acceptance 4	12v/24vdc	
5	5	Car Call acceptance 5	12v/24vdc	
6	6	Car Call acceptance 6	12v/24vdc	
7	7	Up call acceptance 1	12v/24vdc	
8	8	Up call acceptance 2	12v/24vdc	
1	9	Up call acceptance 3	12v/24vdc	Full collective operation
2	10	Up call acceptance 4	12v/24vdc	
3	11	Up call acceptance 5	12v/24vdc	
4	12	Down call acceptance 1	12v/24vdc	
5	13	Down call acceptance 2	12v/24vdc	
6	14	Down call acceptance 3	12v/24vdc	
7	15	Down call acceptance 4	12v/24vdc	
8	16	Down call acceptance 5	12v/24vdc	

EXPANSION I/O BOARD (If Fitted)

CALL INPUTS FOR FULL COLLECTIVE.

No	OUTPUT	DESCRIPTION	VOLTAGE	NOTES
1	1	Car Call acceptance 7	12v/24vdc	Full collective operation
2	2	Car Call acceptance 8	12v/24vdc	
3	3	Car Call acceptance 9	12v/24vdc	
4	4	Car Call acceptance 10	12v/24vdc	
5	5	Car Call acceptance 11	12v/24vdc	
6	6			Not used.
7	7	Up call acceptance 6	12v/24vdc	
8	8	Up call acceptance 7	12v/24vdc	
1	9	Up call acceptance 8	12v/24vdc	Full collective operation
2	10	Up call acceptance 9	12v/24vdc	
3	11	Up call acceptance 10	12v/24vdc	
4	12	Down call acceptance 6	12v/24vdc	
5	13	Down call acceptance 7	12v/24vdc	
6	14	Down call acceptance 8	12v/24vdc	
7	15	Down call acceptance 9	12v/24vdc	
8	16	Down call acceptance 10	12v/24vdc	

NOTE: For second Expansion board, terminal allocation is the same but floor numbers are for 12 to 16

APPENDIX F: Output ratings and description.

POSITION AND DIRECTION.

No	OUTPUT	DESCRIPTION	VOLTAGE	NOTES
1	RD	Up direction arrow	12v/24vdc	
2	RU	Down direction arrow	12v/24vdc	
3	FP6	Floor position o/p 6	12v/24vdc	
4	FP5	Floor position o/p 5	12v/24vdc	
5	FP4	Floor position o/p 4	12v/24vdc	
6	FP3	Floor position o/p 3	12v/24vdc	
7	FP2	Floor position o/p 2	12v/24vdc	
8	FP1	Floor position o/p 1	12v/24vdc	
9	12v/24v	Feed input.		

SIGNAL OUTPUTS.

No	OUTPUT	DESCRIPTION	VOLTAGE	NOTES
1	FFR	Fire Fighting relay	12v/24vdc	Alarm output for firecontrol
2	CLT	Car light control	12v/24vdc	SPA2
3	ALRT	Alarm seen trigger	12v/24vdc	SPA1
4	AGD	Gong/Chime Down	12v/24vdc	
5	AGU	Gong/Chime Up	12v/24vdc	
6	AD	Arrow Down	12v/24vdc	
7	AU	Arrow Up	12v/24vdc	
8	12V/24V	Feed Input	12v/24vdc	Input

RUN OUTPUTS.

No	OUTPUT	DESCRIPTION	VOLTAGE	NOTES
1	OLW	Overload warning output	12v/24vdc	
2	LIS	Lift in service	12v/24vdc	
3	CDT	Close door trigger	110vac	SPA 4 Trigger for speech
4	ODT	Open door trigger	110vac	SPA3 Trigger for speech
5	AC	Anticreep output	110vac	Lock bypass circuit
6	AF	Feed input for above	110vac	Wire to safety chain
7	HSR	High speed relay	110vac	
8	DRR	Down run relay	110vac	
9	URR	Up run relay	110vac	
10	GR	Feed for run outputs	110vac	Wire to safety chain

DOOR CONTROL OUTPUTS.

No	OUTPUT	DESCRIPTION	VOLTAGE	NOTES
1	DOA	Door open alarm	Volt free contact	For Manual doors
2	DOA	Door open alarm	Volt free contact	
3	DNR	Door nudge relay	110vac	
4	RR	Retiring Ramp	110vac	For Manual doors
5	CDR	Close doors relay	Volt free contact	
6	CDR	Close doors relay		
7	ODR	Open doors relay	Volt free contact	
8	ODR	Open doors relay		

APPENDIX F: Output ratings and description.

EXPANSION BOARD AUXILIARY DOOR CONTROL OUTPUTS.

No	OUTPUT	DESCRIPTION	VOLTAGE	NOTES
1				
2				
3				
4				
5	CDRA	Aux door close output	Volt free contact	
6	CDRA	Feed for aux door close	Volt free contact	
7	ODRA	Aux door open output	Volt free contact	
8	ODRA	Feed for aux door open	Volt free contact	

APPENDIX G: NEXUS SPECIFICATION

Key wiring diagram in place of this page

APPENDIX H: Dimensions for UPR, DPR and ACR.

The Nexus lift controller has been designed such that any input must be present for at least 0.08 seconds before it is registered as a valid input. This time delay is to negate any spurious spikes or blips, which could cause inaccurate signals to be seen by the controller.

The following chart shows the distance travelled into a slowing vane on high speed before the processor registers the input from the opto-switch.

LIFT SPEED	FORMULA	DISTANCE
1.0 M/S	1000 /12.5	80 mm
0.9 M/S	900/12.5	72 mm
0.8 M/S	800/12.5	64 mm
0.63 M/S	630/12.5	51 mm
0.5 M/S	500/12.5	40 mm
0.4 M/S	400/12.5	32 mm
0.3 M/S	300/12.5	24 mm
0.15 M/S	150/12.5	12 mm

The chart shows that the longest distance travelled into the slowing vane on high speed is 80 mm at a lift speed of 1.0 M/S.

Based on these calculations all slowing vanes should be cut to a length of 115 mm, which will account for any lift speed up to and including 1.0 M/S.

The floor level stopping vanes (UPR & DPR) should be cut to a length of 115 mm, which allows a nominal levelling speed and advanced door opening, if required.

The door zone vane (ACR) should be cut to a length of 250 mm.

Document prepared by Mr A. Mitchell.

APPENDIX I: Short floor vane Arrangement.

Travelling up: When the lift is travelling up it will increment the floor position when UPR turns ON.

If there is a requirement to stop, the lift will slow to the floor.

If there is NOT a requirement to stop and then the UPS input turns ON, the floor position will increment when the UPR, DPR and ACR inputs are seen to be ON.

If there is a requirement to stop the lift at the new floor position the lift will go into slow speed and stop at floor level.

If the UPS input is present as the lift starts to run up from a stationary position, the lift will increment the floor position.

If there is a requirement to stop at the new floor position, the lift will run in slow speed until UPS turns OFF, and UPR, DPR and ACR are turn ON.

If there is not a requirement to stop the lift will run in high speed to the next call.

Travelling down: As above except lift will decrement the floor position when DPR turns ON and ignore DPR and UPR when DPS is ON.

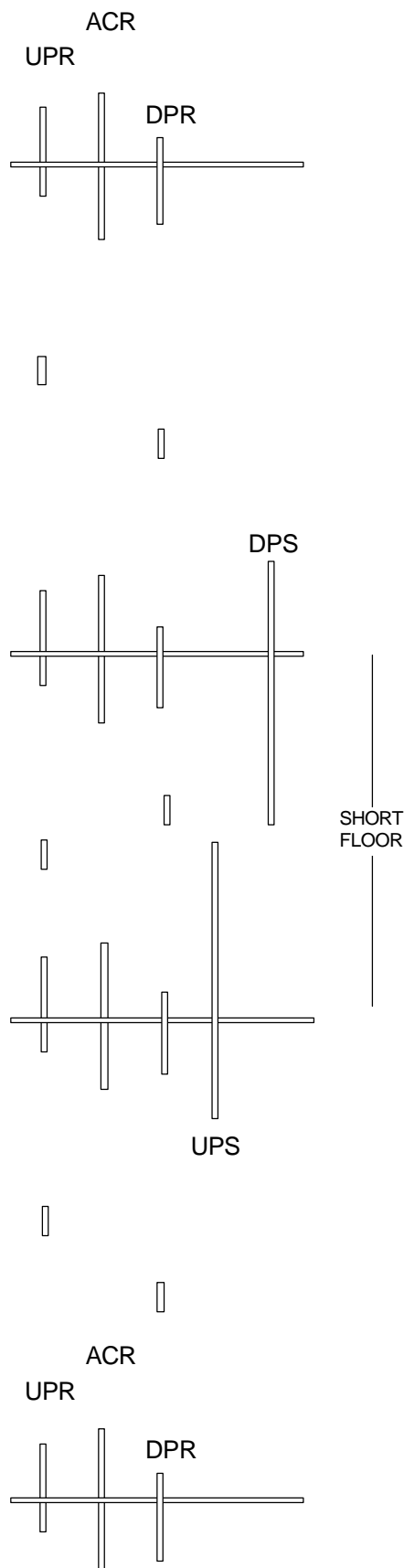

APPENDIX J: Circuit for double door access.

Lift pushbutton signals

Nexus controller inputs

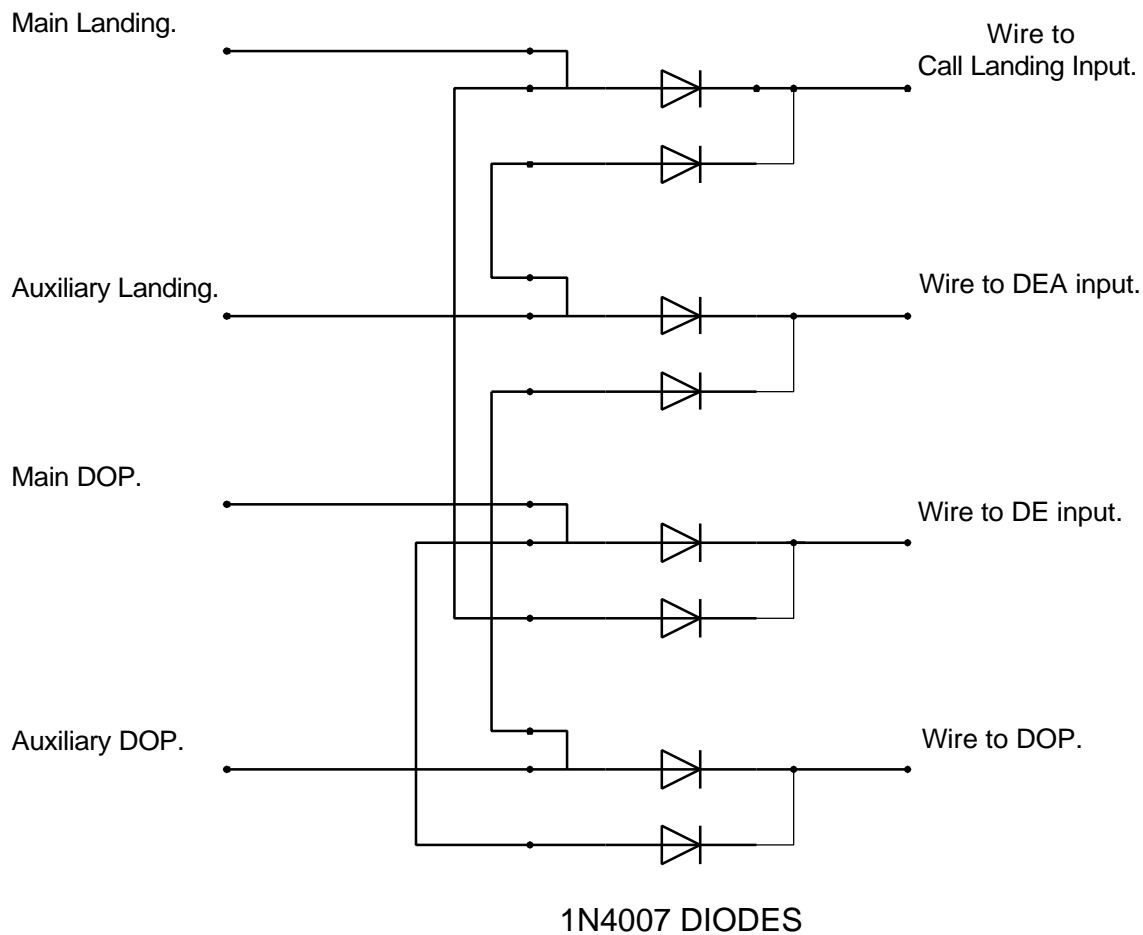

APPENDIX K: NEXUS SPECIFICATION

INSERT MENU DETAILS

FAULT MESSAGE DISPLAY	FAULT DESCRIPTION	POSSIBLE CAUSE
F:00 NFF: NO FAULTS LOGGED,	There are not faults logged.	Memory has been cleared by user.
F:01 SCF: SAFETY CIRCUIT FAULT,	There is a break in the Safety Circuit chain,	No voltage at ST point of safety chain.
F:02	Not used see lock fault F10.	Not used, as per original fault log.
F:03 DJC: MAIN DOOR CLOSE FAULT,	The main doors failed to close in the programmed time	Check door gear or for obstructions
F:04 DCA: AUX DOOR CLOSE FAULT,	The auxiliary doors failed to close in the programmed time	Check door gear or for obstructions
F:05 DJO: MAIN DOOR OPEN FAULT,	The main doors failed to open in the programmed time	Check door gear or for obstructions
F:06 DOA: AUX DOOR OPEN FAULT,	The auxiliary doors failed to open in the programmed time	Check door gear or for obstructions
F:07 DNR: DOOR NUDGE ACTIVATED,	The door nudge was activated.	Obstruction to door movement.
F:08 COC: CALLS CANCELLED,	Calls were cancelled.	Lift failed to run to calls or close doors.
F:09 LSO: LIFT STOP, NO DOOR ZONE,	Lift stopped outside door zone.	Break in run circuit while lift running.
F:10 GLH: G1 LOCK TRIPPED IN HIGH SPEED	G1 Lock tripped while in high speed.	Doors opened while lift running in highspeed
F:10 GLH: G2 LOCK TRIPPED IN HIGH SPEED	G2 Lock tripped while in high speed.	
F:10 GLH: G3 LOCK TRIPPED IN HIGH SPEED	G3 Lock tripped while in high speed.	
F:11 GLL: G1 LOCK TRIPPED IN LOW SPEED	G1 Lock tripped while in low speed.	Doors opened while lift running in low speed
F:11 GLL: G2 LOCK TRIPPED IN LOW SPEED	G2 Lock tripped while in low speed.	
F:11 GLL: G3 LOCK TRIPPED IN LOW SPEED	G1 Lock tripped while in low speed.	
F:12 OLW: OVERLOADED LIFT,	Lift overloaded.	Overload level 3 shutdown condition
F:13 TRC: LIFT ON TEST CONTROL,	Lift on test control, TRC = OFF.	Lift on car top control.
F:14	There is no fault F:14.	
F:15 FMC: FIREMAN'S CONTROL ON,	Fireman's control activated.	Fire control activated.
F:16 URS: TOP RESET ACTIVE,	UP terminal floor reset activated	Lift out of position check UPR vanes
F:17 DRS: BOTTOM RESET ACTIVE,	Down terminal floor reset activated	Lift out of position check DPR vanes
F:18 USL: UP LIMIT BROKEN,	Lift stopped by UP stop limit.	Lift overrun, check vane settings.
F:19 DSL:DOWN LIMIT BROKEN,	Lift stopped by DOWN stop limit.	Lift overrun, check vane settings.
F:20 LTF: LIFT RAN THROUGH FLOOR,	Lift travelled through floor.	Check vane and stop delay.
F:21 URN: UC NOT ENERGISED,	UC contactor not energised.	UC input not seen within programmed delay.
F:22 DRN: DC NOT ENERGISED,	DC contactor not energised.	DC input not seen within programmed delay.
F:23 CDN: CDC NOT ENERGISED,	CDC not energised.	CDC input not seen within delay.
F:24 CAN: CDCA NOT ENERGISED,	CDCA not energised.	CDCA input not seen within delay.
F:25 ODN: ODC NOT ENERGISED,	ODC not energised.	ODC input not seen within delay.
F:26 OAN: ODCA NOT ENERGISED,	ODCA not energised.	ODCA input not seen within delay.
F:27 DPO: DOOR PUSH OPEN, STUCK IN,	Main door open push stuck in.	Check push button for sticking or misuse.
F:28 DPA: AUX PUSH OPEN, STUCK IN,	Auxiliary door open push stuck in.	Check push button for sticking or misuse.
F:29 RES: LIFT RESET ON POWER UP,	Power up caused lift to reset.	If frequent, check electrical supply for noise

FAULT MESSAGE DISPLAY

FAULT DESCRIPTION

POSSIBLE CAUSE

F:30 RSH: STARTS PER HOUR EXCEEDED,	Lift exceeded rated starts per 15 minute.	Check traffic requirements.
F:31 JTT: JOURNEY TIME EXCEEDED,	Lift journey timer tripped.	Check run circuit and vanes.
F:32 PIA: I/O BOARD FAULT,	Minor fault detected with unit hardware.	Nexus internal fault detected.
F:32 PIA: I/O BOARD FAULT,	Fatal fault detected with unit hardware.	Nexus internal fatal fault detected.
F:33 DPX: FAULT ON DUPLEX LINK,	Communication problem on duplex comms link.	Check terminations or cable routing.
F:34 DPL: CORRUPTED DUPLEX LINK,	Excessive communication errors on duplex comms link.	Check terminations or cable routing.
F:35 RAM: CORRUPT MEMORY,	CPU, RAM memory fault.	Check power source for electrical noise.
F:36 ULR: ULTIMATE LIMIT BROKEN,	Lift over ran the ultimate limit.	Check setting of vanes and limits.
F:37 HSC: HSC NOT ENERGISED,	HSC contactor failed to energise.	HSC input not seen within delay.
F:37 HSC: HSC NOT RELEASED,	HSC contactor failed to release.	HSC input not turned OFF within delay.
F:38 PS1: 110vac SUPPLY LOST,	Failure of the 110v ac Supply.	Check supply wiring and fuses.
F:39 PS2: 110vdc SUPPLY LOST,	Failure of the 110v dc Supply.	Check supply wiring and fuses.
F:40 PS3: FP FEED SUPPLY LOST,	Failure of the FP Feed.	Check supply wiring and fuses.
F:41 PS4: AF SIGNAL NOT PRESENT,	Failure of the AF Signal feed.	No voltage at AF point of safety chain.
F:42 ALR: ALARM PUSH OPERATED.	Alarm push operated for more than 3 seconds.	
F:43 SBF: STUCK BUTTON,	Button ON for more than set time.	Check for sticking buttons or misuse.
F:44 LIM: POSITION CURRENT LIMIT,	Over current condition on a unit output.	Check load and wiring for short circuits.
F:44 LIM: CALL ACC 1-8 CURRENT LIMIT,	Over current condition on a unit output.	Check load and wiring for short circuits.
F:44 LIM: CALL ACC 9-16 CURRENT LIMIT,	Over current condition on a unit output.	Check load and wiring for short circuits.
F:44 LIM: EXP 1 O/P1 CURRENT LIMIT,	Over current condition on a unit output.	Check load and wiring for short circuits.
F:44 LIM: EXP 1 O/P2 CURRENT LIMIT,	Over current condition on a unit output.	Check load and wiring for short circuits.
F:44 LIM: EXP 2 O/P1 CURRENT LIMIT,	Over current condition on a unit output.	Check load and wiring for short circuits.
F:44 LIM: EXP 2 O/P2 CURRENT LIMIT,	Over current condition on a unit output.	Check load and wiring for short circuits.
F:45 RLL: RE-LEVEL TIMEOUT,	Anticreep ran for more than time limit.	Check run circuit, vanes and Hydraulics.
F:46 BWN: POWER BROWN OUT,	Recovered from power brown out.	Check power source for noise.
F:47 OVT: OVER_TEMP SHUTDOWN,	Motor over temperature shutdown input.	Check motor cooling and lift use.
F:48 OL2: BYPASS LANDING CALLS,	Lift overloaded, landing calls will be bypassed.	Overload 2 call bypass, check lift use

NOTES:

1. Faults are only logged if the unit operates in a different manner to the programmed parameters.
That is: If the unit has not been programmed to open it's doors at a floor, it will not open the doors and will NOT log a fault, as no fault has occurred.
2. If the contactor delay time is programmed to be too short, UC, DC, ODC, CDC, or HSC faults will be logged. Even though the circuit works. The contactor delay times COT: Contact Delay and CRT: Contact release delay, must be programmed for longest possible delay. That is, for an output to propagate through the circuit to the contactor wired to the relevant input.

SET AND VIEW REGISTER MESSAGES

FP: FLOOR POSITION 01
 GCR: GOODS CONTROL
 FMC: FIRE CONTROL
 DOP: OPEN PUSH
 DCP: CLOSE PUSH.
 DOA: AUX OPEN
 DORX: DOOR EXTEND
 OL2: CALL BYPASS
 OL3: OVERLOAD
 SLD1: SHUTDOWN 1
 SDL2: SHUTDOWN 2
 ALR: ALARM INPUT
 HOM: HOME IN 5s
 SAFETY: 00000000B
 DOORS I/P: 00000000B
 RUN I/P: 00000000B
 PROXIMITY: 00000000B
 LIFT CTRL: 00000000B
 CALL 1-8: 00000000B
 CALL 9-16: 00000000B
 EXP1 I/P1: 00000000B
 EXP1 I/P2: 00000000B
 EXP2 I/P1: 00000000B
 EPX2 I/P2 : 00000000B
 DOOR O/P: 00000000B
 RUN O/P: 00000000B
 SIGNAL O/P: 00000000B
 POSITION: 00000000B
 ACK 1_8: 00000000B
 ACK 1_16: 00000000B
 EXP1 O/P1: 00000000B
 EXP1 O/P2: 00000000B
 EXP2 O/P1: 00000000B
 EXP2 O/P2: 00000000B

DESCRIPTION OF FUNCTION

The Floor position can be modified using this screen
 Control of the Goods control input (GCR) is possible using this screen.
 Control of the Fire control input (FMC) is possible using this screen.
 Control of the Door open button (DOP) is possible using this screen.
 Control of the Door close button (DCP) is possible using this screen.
 Control of the Auxiliary Door open button (DOP) is possible using this screen.
 Control of the Extend Door open button (DORX) is possible using this screen.
 Control of the Overload 2 input (OL2) for landing call by pass is possible using this screen.
 Control of the Overload 3 input (OL3) for shut down of lift is possible using this screen.
 Control of the Shutdown 1 (SDL1) is possible using this screen.
 Control of the Shutdown 2 (SDL2) is possible using this screen.
 Control of the Alarm input (ALRM) is possible using this screen.
 Lift will home to homing floor in 5 seconds time when this input set to ON. **DOES NOT WORK.**
 Allows Safety inputs to be viewed but not modified.
 Allows Door inputs to be viewed but not modified.
 Allows Run inputs to be viewed but not modified.
 Allows Proximity to be viewed but not modified.
 Allows Lift control inputs to be viewed but not modified.
 Allows Call inputs 1 to 8 can be viewed but not modified.
 Allows Call inputs 9 to 16 can be viewed but not modified.
 Allows Expansion board 1 input group 1 to be viewed but not modified.
 Allows Expansion board 1 input group 2 to be viewed but not modified.
 Allows Expansion board 2 input group 1 to be viewed but not modified.
 Allows Expansion board 2 input group 2 to be viewed but not modified.
 Allows Door outputs to be viewed but not modified.
 Allows Run outputs to be viewed but not modified.
 Allows Signal outputs to be viewed but not modified.
 Allows Position outputs to be viewed but not modified.
 Allows Call acceptance outputs 1 to 8 to be viewed but not modified.
 Allows Call acceptance outputs 9 to 16 to be viewed but not modified.
 Allows expansion board 1 outputs 1 to be viewed but not modified.
 Allows expansion board 1 outputs 2 to be viewed but not modified.
 Allows expansion board 2 outputs 1 to be viewed but not modified.
 Allows expansion board 2 outputs 2 to be viewed but not modified.

APPENDIX N: LIST OF PROGRAMMABLE PARAMETERS

PROGRAM MESSAGES	DEFAULT	MIN	MAX	DESCRIPTION OF PROGRAM MESSAGE.
SIT: SITE No: L000001,	L000001			Site number for lift. This will be the JOB number.
LFT: LIFT No: 00,	1	1	99	Lift number. For multiple lifts on a site each will be programmed with a lift number.
PIC: PROG TYPE SIMPL,	SIMPLEX			Type of program fitted: simplex, Duplex (Multi lift).
VER: VERSION 01.31,	1.31			Version number of program fitted to unit.
SBC:SB, COLLECTIVE,	YES	NO	YES	If selected, Lift will operate as a Single Button collective.
FDC: FULL COLLECTIVE,	NO	NO	YES	If selected, Lift will operate as a Full collective.
HDC: DOWN COLLECTIVE,	NO	NO	YES	If selected, Lift will operate as a DOWN collective.
LUC: UP COLLECTIVE,	NO	NO	YES	If selected, Lift will operate as a UP collective.
NFL: No OF FLOORS,	3	1	15	Programmed for the number of floors.
RSD: DOWN RESET,	1	1	1	Programmed for the bottom reset floor. Default is position 1..
RSU: TOP RESET,	3	1	15	Programmed for the top reset floor. Default is position 5.
FLO: FLOOR O/P	1 / FLOOR	BINARY	GRAY	Floor display output format.
RLL: RELEVEL,	YES	NO	YES	To disable Anticreep fit link LK6, next to IC13 socket, and selected to be OFF, on menu.
RL1: RELEVEL INT,	5 SEC	5 SEC	20 SEC	Initial relevel delay: Programmed delay before Lift relevers.
RL2: RELEVEL OPEN,	10 SEC	1 SEC	10 SEC	Programmed delay before lift relevers, if doors are open.
RL3: RELEVEL LIM,	8 SEC			Time limit for anticreep to be ON.
RL4: RELEVEL MAX ,	5	1	10	Maximum number of relevers allowed at any one floor.
RL5: RELEVEL RST,	10 MIN	10 MIN	120 MIN	Time after exceeding downwards relevel limit before lift will attempt to relevel down again
HOM: AUTO HOMING,	YES	NO	YES	Enable automatic Homing.
HTT: HOMING TIMER,	15 MIN	1 MIN	60 MIN	Set for time before homing occurs.
HTF: HOMING FLOOR,	1	1	15	Set for floor Lift will run to when homing.
MND: MANUAL DOOR,	NO	NO	YES	Set to yes if Manual doors fitted.
ADO: ADV OPEN,	YES	NO	YES	Set to yes if advanced door open required.
DJT: DOOR MOTION,	10 SEC	5 SEC	15 SEC	Set for door opening and closing time.
DOT: OPEN TIME,	6 SEC	1 SEC	30 SEC	Set to the main door open pause time.
DHT: EXD OPEN,	20 SEC	5 SEC	60 SEC	Set for the main door extended open time.
DDT: REVERSE DLY,	0.2 SEC	0.1 SEC	0.9 SEC	Set for the Main door quick reverse delay.
AUX: AUX DOORS,	NO	NO	YES	Set if auxiliary doors fitted.
DJA: AUX MOTION,	10 SEC	5 SEC	15 SEC	Set for the Auxiliary door opening and closing time.
DOA: AUX OPEN,	6 SEC	1 SEC	30 SEC	Set for the Auxiliary door open pause time.
DHA: AUX EXD OPEN,	20 SEC	5 SEC	60 SEC	Set for the Auxiliary door extended open time.
DDA: AUX REV DLY,	0.2 SEC	0.1 SEC	0.9 SEC	Set for the auxiliary door quick reverse.
PFL: FLR LOCKOUT,	NO	NO	YES	set to YES to inhibit main and auxiliary doors opening at the same floor
DNR: DOOR NUDGE,	NO	NO	YES	Set to YES to enable door nudge.
DNO: DOOR OPS,	10	1	10	Set for the number of door ops before door nudge starts.

APPENDIX N: LIST OF PROGRAMMABLE PARAMETERS

PROGRAM MESSAGES	DEFAULT	MIN	MAX	DESCRIPTION OF PROGRAM MESSAGE.
CDD: LOCK TEST DLY,	5 SEC	1 SEC	20 SEC	Set for delay before locks are checked.
COT: CONTACT DLY,	0.9 SEC	0.1 SEC	1 SEC	Set for time for contactors to make after being energised
CRT: CONTACT REL,	0.9 SEC	0.1 SEC	1 SEC	Set for time for contactors to release after being energised.
FMR: FIRE RESET,	YES	NO	YES	Set to YES for Lift to run to fire floor upon Fireman's control turning ON.
FMS: FIRECONTROL,	NO	NO	YES	Set to YES if Lift is a firefighting Lift.
MFR: FIRE FLOOR,	1	1	15	Set for floor that Lift will run to when Fireman's control turns ON.
SDL1: SHUTDOWN 1,	1	1	15	Set to floor that Lift will run to when shutdown 1 turns ON.
SDL2: SHUTDOWN 2,	1	1	15	Set to floor that Lift will run to when shutdown 2 turns ON.
AST: START DELAY,	1 SEC	1 SEC	9 SEC	Set for delay before Lift runs.
LRT: STOP DELAY,	0.1 SEC	0.1 SEC	0.8 SEC	Set for delay before lift stops, used for levelling.
RSH: START / HOUR,	23	1	99	Set for number of starts allowed with a 15 minute period.
JTT: JOURNEY TIME,	45 SEC	60 SEC	180 SEC	Set for maximum allowable travel time.
OTM: O/T MAX TIME	20 SEC			
AGT: GONG TIMER,	CONT	1	9	Set for continuous or instantaneous, in tenth of a second
CCT: CANCEL TIMER,	2 MIN	1 MIN	10 MIN	Set for time before calls are automatically cancelled.
CZT: CALL RST TIME,	4 MIN	1 MIN	10 MIN	Set for time that lift will shutdown due to a call cancel shutdown.
SBT: STUCK BUTTON,	30 SEC	10 SEC	60 SEC	Set for time that a call button can be continuously ON.
TRC: TRC RESET,	NO	NO	YES	Set to YES, if Lift is to reset to bottom floor after Test control turns OFF.
TCO: FLASH ON TEST,	YES	NO	YES	Set to YES if position indicator is to flash when Lift not in normal service.
CLD: CAR LAMP DELAY,	2 MIN	1 MIN	60 MIN	Delay before car lights are turned OFF.
EX1: EXTEND1 BRD,	NO	NO	YES	The unit will automatically display YES, if the board is present.
EX2: EXTEND2 BRD,	NO	NO	YES	The unit will automatically display YES, if the board is present.
EX3: EXTEND3 BRD,	NO	NO	YES	The unit will automatically display YES, if the board is present.

APPENDIX O: INSTRUCTIONS FOR CHANGING PROGRAM MEMORY

Safety first:

1. Ensure Lift programmable parameters and door options have been recorded and are up to date.
2. Set Lift to a safe condition and isolate control panel from all power feeds.

Changing program memory:

1. Open the Nexus Lift Controller front panel by releasing the retaining screw, located near the power supply inputs.
2. The program memory chip is located beneath the display module, release the display module by undoing the two M3 nuts either side of the display module. The display module can be supported by its cable but it must not be unduly stretched or twisted.
3. The program memory chip is mounted in a socket and is labelled 'NEXUS VER 1.3x', the version number may have changed. Note the orientation of the chip. The orientation of the chip is denoted by a NOTCH at one end.
4. Remove the chip by carefully 'prizing' it out of the socket. Care must be taken not to damage any adjacent component or the circuit board. Once the chip has been removed it should be kept in a safe place until the lift has been tested. It should then be discarded.
5. Fit the replacement chip in the correct orientation ensuring that the legs do not bend.
6. Inspect the chip for bent legs.
7. Refit the display module and secure with the two M3 nuts. Washers are not fitted to the display module.
8. Close the Nexus Lift Controller unit front panel.
9. Apply power to the unit and check the programmable parameters, if these have changed reprogram unit to original values. See section 6 for information on how to program the unit.
10. Updating of the Lift software is now complete.

END OF INSTRUCTIONS.