

Waiver:

This data sheet is for guidance only and must not be used for proper working drawings. Please contact Stannah Lifts for particular details before proceeding. Owing to our policy of continual improvement we reserve the right to alter specifications and dimensions without prior notice.

For guidance only

THE STANNAH STAIRISER CR

Curved Rail
Wheelchair Platform Stairlift
Parking Options

Stannah

Parking Options

- ◆ The stairlift is normally parked at the lower level.
- ◆ Parking can be in-line with the travel but where possible the lift should be parked away from the staircase.
- ◆ Parking off the staircase is achieved by turning the platform through 90° or 180° once it has traversed the bottom step of the staircase.
- ◆ Consideration should be given to allow adequate space at the landings for users to be able to comfortably access & egress from the lift platform.
- ◆ For in-line parking of the platform a turning distance of 1500mm is recommended.
- ◆ If lower landing space is limited, steep start rail or side load platform options can be considered. Refer to Information Sheet ACL 510 for details of *Steep Start*.

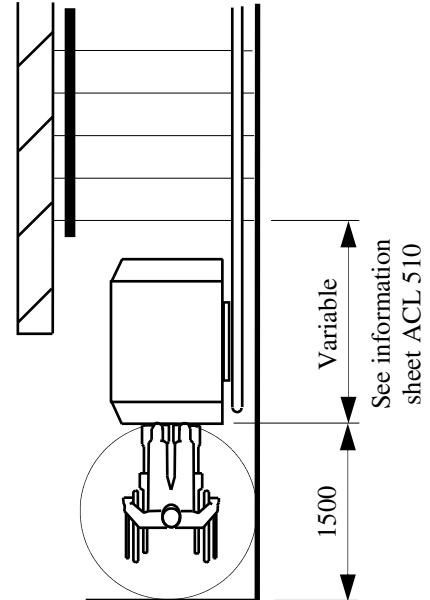

In Line Parking

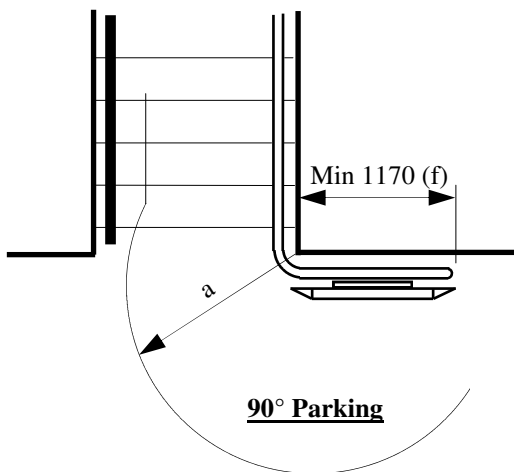

a = 1146mm Support Pillar Fixed
1084 Wall Mounted

— Handrail
= Lift Rail

- ◆ Top Landing Access - Sufficient area is required on the top landing for a wheelchair user to exit the lift platform.
- ◆ Top Landing Parking - The platform can be parked at the top of the lift travel. This is not recommended unless it is impractical to park at the bottom level. In such conditions, clearance requirements may apply - refer to information sheet ACL 511 *Building Regulations*.
- ◆ The minimum parking space (dimension 'f' see sketches) is based on end ramp lengths of 200mm. For 150mm end ramps, 'f' reduces to 1070mm.

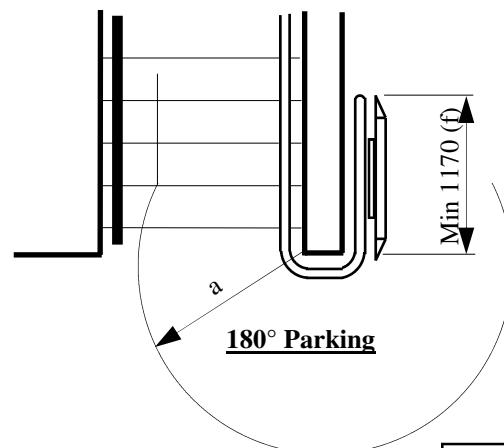

INFORMATION SHEET
No. ACL 512
09.08.18