

**MIDLIFT XL PLUS
MAINTENANCE GUIDE**

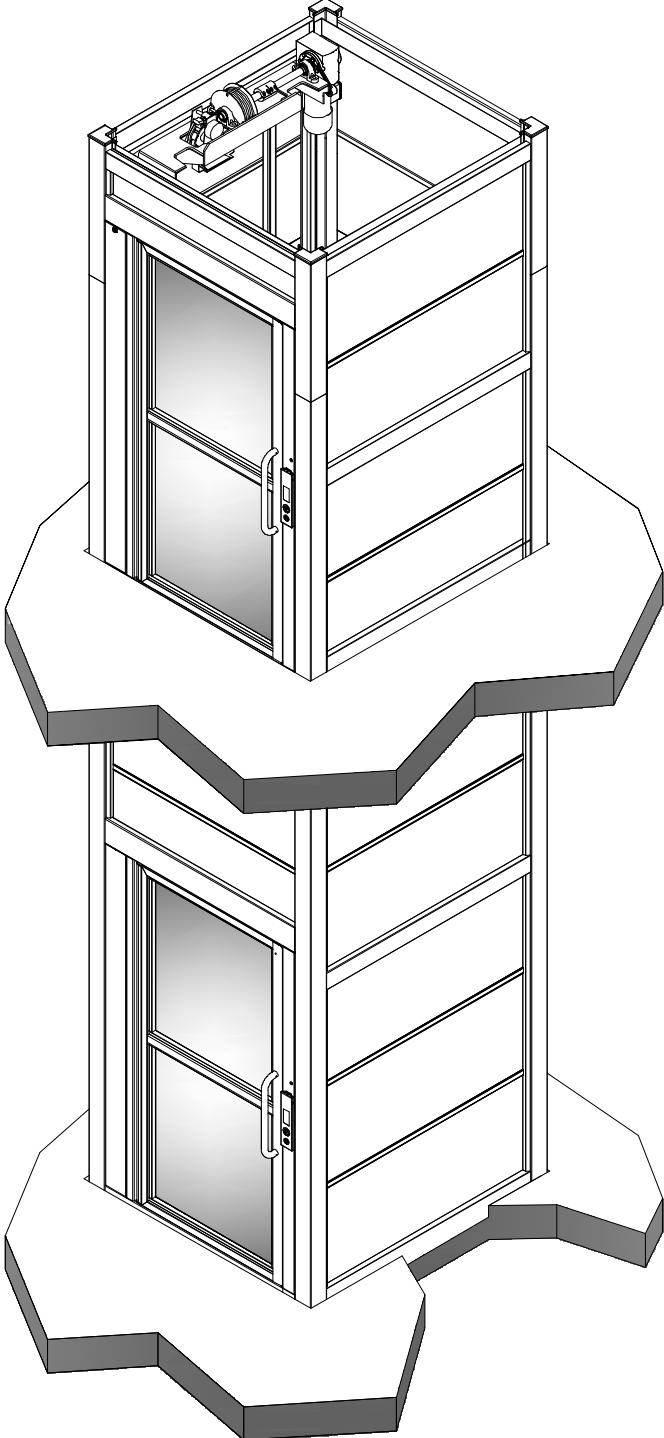

CONTENTS LIST

1	INTRODUCTION	4
2	SAFETY	4
3	CLEANING	4
4	LIFT ACCESS AND PROCEDURES	4
4.1	Cabin Access	4
4.2	Cabin operating panel (COP) removed	4
4.3	Upper floor landing controls	4
4.4	Ceiling removed	5
4.5	COP and rear wall removed	5
4.6	Overspeed governor tests	5
4.7	Brake assembly	5
4.8	Load weighing device – Rated load setup	5
4.9	Load weighing device – Calibration	5
5	SERVICING	5
6	CUSTOMER COMMUNICATIONS	5
7	TOOLING REQUIREMENT	6
8	MAINTENANCE BREAKDOWN	6
8.1	Essential requirement / Visual checks	6
8.2	Phase 1	6
8.3	Phase 2	7
8.4	Phase 3	7
8.5	Phase 4	7
8.6	5 year check	7
8.7	Additional checks	7
9	MAINTENANCE INSTRUCTION – ESSENTIAL MAINTENANCE	9
9.1	Smoothness of ride	9
9.2	Cabin lighting	9
9.3	Floor covering	9
9.4	Name plate	10
9.5	Car fixtures	10
9.6	Car walls	10
9.7	Floor levels	10
9.8	Emergency equipment	10
9.9	Safety edges	11
9.10	Light Curtains	11
9.11	Control panels	11
9.12	Brake operation	12
9.13	Door operation	12
9.14	Landing door locks and beaks	12
9.15	Indicators (DDU's and push buttons etc...)	12
9.16	Visual inspection/light clean	13
10	MAINTENANCE INSTRUCTION – PHASE 1	13
10.1	Risk assessment and general lift check	13
10.2	Car overload	13
10.3	Manual release	14
10.4	Rope connections and wear/stretch	14
10.5	Earth bonding, insulation and electrical	15
11	MAINTENANCE INSTRUCTION – PHASE 2	15
11.1	Roof top	15
11.2	Upper shaft work	15
11.3	Drive shaft bearings	16
11.4	Ultimate limit switch	16
11.5	Safety gear and overspeed governor	17
11.6	Encoder and timing belt	17
11.7	Guides and fixings	18
11.8	Trailing cable and chain	18
11.9	Sling and car fixtures	19
11.10	Gearbox/motor	19
12	MAINTENANCE INSTRUCTION – PHASE 3	19
12.1	Counterweight	19

12.2	Pit buffer	20
12.3	Tension Pulley.....	20
12.4	Cabin floor	21
12.5	Pit clean.....	21
13	MAINTENANCE INSTRUCTION – PHASE 4.....	21
13.1	Brake lining.....	21
13.2	Thorough clean	22
14	5 YEAR MAINTENANCE CHECKS.....	22
14.1	Gearbox/motor detailed check	22
14.2	Earth bonding, insulation and electrical visual	22
14.3	Safety gear and overspeed governor (Full safety activation required)	23
15	ADDITIONAL CHECKS	23
15.1	Autodialer	23
15.2	Telephone	24
15.3	Intercom	24
15.4	Power door operator	24
15.5	Fire alarm shut down.....	24
15.6	UPS	25
16	APPENDIX A.....	26
16.1	Cabin operating panel (COP) removed.....	26
16.2	Upper floor landing controls	27
16.3	Ceiling removed - Important note: persons are not permitted to stand on car roof	28
16.4	COP and rear wall removed.....	29
17	APPENDIX B.....	30
17.1	Brake lining.....	30
17.2	Overspeed governor activation tests – for contracts with remote test control OSG activation button only (see 17.3 for contracts without remote OSG activation)	31
17.3	Overspeed governor activation tests – for contracts without remote test control OSG activation button only (see 17.2 for contracts with remote OSG activation)	32
17.4	Overspeed lift	33
17.5	Set the lift to run at 80.0 Hz.....	34
17.6	Re set the lift to run at 50.0 Hz	34
17.7	Overload controller calibrations.....	35
17.8	Overload alarm setup.....	35
17.9	Safety chain switch locations	36
18	DOCUMENT HISTORY	38

1 INTRODUCTION

This maintenance guide is to help provide understanding of the correct maintenance schedule.

Your Platform Lift has been manufactured and installed to comply with the Essential Safety Requirements of the Machinery Directive 2006/42/EC and a correct maintenance schedule will ensure that the lift will be kept in optimum condition.

This schedule has been designed for use by approved engineers/technicians who have completed the recognised training course.

2 SAFETY

As stated it is imperative that any work carried out the lift is performed by suitably trained technicians. When completing any component replacement, ensure that the lift is isolated from the mains electrical supply. This can be achieved using the mains isolation, usually situated within a 5m radius of the upper floor entrance.

If there is any doubt that a lift cannot be left in safe condition, then the customer and supervisor are to be consulted, advising that the lift may be removed from service. A report should be included in this procedure advising on the full remedial work. The ultimate decision of continued use rests with the owner, but should the owner ignore the advice to switch off, the branch manager should be informed.

3 CLEANING

As part of all maintenance checks to be complete on the lift, there will be a requirement of some level of cleaning. The following shows area of cleaning required and recommended cleaning procedures.

Paint finishes – These should be cleaned with a damp cloth using an aerosol type of furniture polish.

Stainless steel – This should be cleaned with a soft cloth soaked in light oil (“3 in 1” or “Johnson’s baby oil”) and then wiped off with a dry lint-free cloth.

Vinyl skin plate or laminate boards – This should be cleaned with a soft cloth using an aerosol type of furniture polish.

Mirrors or glass – These should be cleaned with a soft cloth and any glass cleaning product.

Note: The inside of the liftwell enclosure can be cleaned only by a competent lift maintenance engineer by using a suitable step ladder located inside the cabin and working through the hinged-down cabin ceiling.

Platform Flooring – This should be cleaned with a damp cloth and a mild detergent. Ensure that excess water is squeezed out prior to cleaning.

4 LIFT ACCESS AND PROCEDURES

For the various maintenance checks different levels of lift access will be required. These levels of access are listed below and can be displayed in more detail later within this document.

4.1 Cabin Access

Cabin access is the process of entering the lift to ride up and down completing simple routine checks.

4.2 Cabin operating panel (COP) removed

Behind the COP lays the load weighing device and the main lift controller. (*16.1 Cabin operating panel (COP) removed, pg 26*).

4.3 Upper floor landing controls

There are two areas where these controls may be located either in an external controller or within the upper landing door. (*16.2 Upper floor landing controls, pg 27*).

4.4 Ceiling removed

Behind the ceiling lays the cabin lighting and terminal rail for the light curtains. The ceiling must also be removed to access all items within the top of the shaft. **Important note: Persons are not permitted to stand on the car roof.** (16.3 *Ceiling removed pg 28*).

4.5 COP and rear wall removed

To access such items as the safety gear, door ramps and encoder the whole rear panel must be removed. (16.4 *COP and rear wall removed pg 29*).

4.6 Overspeed governor tests

To complete a test on the safety gear and overspeed governor, a safe working procedure has been drawn up. (17.2 & 17.3 *Overspeed governor activation tests, pg 31/31*).

4.7 Brake assembly

As part of the brake assembly, the brake lining will need to be checked, either through suspicion of brake wear, or as part of the annual service checks (17.1 *Brake lining, pg 30*).

4.8 Load weighing device – Rated load setup

To complete various tests within the maintenance schedule it is sometimes necessary to alter the rated load setup on the load weighting device (17.8 *Overload alarm setup, pg 35*).

4.9 Load weighing device – Calibration

If for any reason the load weighing device is not working in the correct manner, it may be necessary to re calibrate the unit (17.7 *Overload controller calibrations, pg 35*).

5 SERVICING

There will be 4 annual services consisting of various maintenance checks. Full instructions for all checks can be found within this document including diagrams where necessary. It has been assumed that all persons carrying out these checks will have prior servicing knowledge and be comfortable with basic lift maintenance.

The annual schedule is split into two areas. These will be essential checks (checks that must be completed at every visit) and phased checks (checks completed annually). Phased checks are broken down into four areas.

To ensure that the maintenance visit remains as efficient as possible the 4 phases will consist of the 4 different areas of lift access. These phases have been clearly marked on the log card for ease of use by the engineer.

In addition to the essential and phase checks, it will be necessary for the engineer to complete additional supplementary checks. These will become apparent due to added options on the lift and checks that fall out of the annual category (more than 1 year per check).

6 CUSTOMER COMMUNICATIONS

It is very important to talk to the customer about the lift, whilst not being an expert in the field, on occasions they may know about their specific lift better than the engineers. Listen to them and address the points raised or at least allay their fears in a sensitive way. It is rare that the passengers complain unnecessary; however it is even rarer that they will describe it to you in engineering terms.

Although the service of the lift is within the responsibility of the service branch and engineer in question, the overall responsibility of the lift lies with the customer. Thus taking the lift out of service will be the final decision of the customer. For this reason, where appropriate the engineer will have the responsibility to convince the customer of the necessity to take the lift out of service.

7 TOOLING REQUIREMENT

- General fitters tools plus the following more specialised items,
- Feeler gauge
- Torque wrench
- Multi-meter
- Mega meter
- Labelled electrical shorting wires
- XLplus maintenance keys
- Secondary safety brackets (6203018 x 2)

8 MAINTENANCE BREAKDOWN

8.1 Essential requirement / Visual checks

- Smoothness of ride (*pg 9*)
- Cabin lighting (*pg 9*)
- Floor covering (*pg 9*)
- Name plate (*pg 10*)
- Car fixtures (*pg 10*)
- Car walls (*pg 10*)
- Floor levels (*pg 10*)
- Emergency equipment (*pg 10*)
- Safety edges (*pg 11*)
- Light Curtains (*pg 11*)
- Control panels (*pg 11*)
- Brake operation (*pg 12*)
- Door operation (*pg 12*)
- Landing door locks and beaks (*pg 12*)
- Indicators, DDU's and push buttons etc... (*pg 12*)
- Visual inspection/light clean (*pg 13*)

8.2 Phase 1

- a) Risk assessment (*pg 13*)
- b) Car overload (*pg 13*)

- c) Manual release (*pg 14*)
- d) Rope Connections and wear/stretch (*pg 14*)
- e) Earth bonding, insulation and electrical visual check (*pg 15*)

8.3 Phase 2

- f) Roof top (*pg 15*)
- g) Upper shaft work (*pg 15*)
- h) Drive shaft bearings (*pg 15*)
- i) Ultimate limit (*pg 16*)
- j) Safety gear and overspeed governor (*pg 17*)
- k) Encoder and timing belt (*pg 17*)
- l) Guide and fixings (*pg 18*)
- m) Trailing cable and chain (*pg 18*)
- n) Slings and car fixtures (*pg 19*)
- o) Gearbox/motor (*pg 19*)

8.4 Phase 3

- p) Counterweight (*pg 19*)
- q) Pit buffer (*pg 20*)
- r) Tension pulley (*pg 20*)
- s) Cabin Floor (*pg 21*)
- t) Pit clean (*pg 21*)

8.5 Phase 4

- u) Brake lining (*pg 21*)
- v) Thorough clean (*pg 22*)

8.6 5 year check

- Motor and gear box detailed check (*pg 22*)
- Earth bonding, insulation and electrical visual check (*pg 22*)
- Overspeed governor and safety gear (*pg 23*)

8.7 Additional checks

- Autodialer (*pg 23*)

- Telephone (*pg 24*)
- Intercom (*pg 24*)
- Power door operator (*pg 24*)
- Fire alarm shut (*pg 24*)
- UPS (*pg 25*)

9 MAINTENANCE INSTRUCTION – ESSENTIAL MAINTENANCE

As discussed earlier within this document, any engineer completing the service can be assumed to have had the relevant training and have a suitable knowledge of lift technology. Where further instruction is required, this will be contained in this section of the guide.

As part of the maintenance guide a detailed instruction to of the required standard will be given, if for any reason an area of the lift falls short of this required standard, this part of the guide will also state clearly the corrective action expected of the engineer.

9.1 Smoothness of ride

- Required standard

Whilst travelling to top floor and back there must be no knocks, scrapes, groans, vibrations etc... There is to be minimum vibration with no jolts or juddering and a smooth speed change over.

- Required action

The cause of any unusual noise and vibration must be investigated and if not cured immediately, then reported to a supervisor with details of suggested remedial work. Vibration sources may indicate bearing failure on a high speed shaft; therefore it is imperative it is investigated.

A poor quality ride may also be down to the quality of guides and this can be solved by dressing the guides.

9.2 Cabin lighting

- Required standard

There must be no sign of damage, lighting equal, retaining clips in place (where used) and diffusers (where used) free from cracks or damage.

If the lift is not in use, the cabin lights should switch off after approximately 3 minutes.

- Required action

If the required components are to hand and the work to restore lighting is possible, remedial work is to be complete and supervisor to be informed. If repair work is not possible and the lift is in an unsafe working condition the customer must be informed of the removal from service until the required corrective work is complete.

9.3 Floor covering

- Required standard

Floor covering to be secure, flat and without distortion and with no tripping hazards.

- Required action

If a tripping hazard cannot be made safe, then consult customer and report to supervisor that the lift may have to be removed from service, with details of suggested remedial work.

Note: more injuries are caused by tripping than lift component failure.

9.4 Name plate

- Required standard

Name plate must be securely fixed and clearly show place of manufacture, CE mark, Lift job number and product name (XL Plus).

Also clearly within the cabin should be the lifts working load. For a standard XL Plus lift, this will be 400kg. If in doubt of the working load ask.

- Required action

It is legally required to have above details indicated. If this is not in place consult with customer and supervisor about the possibility of taking the lift out of service.

9.5 Car fixtures

- Required standard

The security of handrails and mirrors should be in good condition with no sharp edges.

- Required action

Make safe any condition likely to cause harm.

9.6 Car walls

- Required standard

All walls should be secure and free from any damage. Pay particular attention to glass panels to check for any cracks or scratches.

- Required action

If there are any gaps in the car walls or damage to the walls that cannot be repaired immediately, then consult customer and report to supervisor that the lift may have to be removed from service, with details of suggested remedial work.

9.7 Floor levels

- Required standard

As part of EN81-41 2009, the lift must stop within ± 10 mm of floor level.

- Required action

If floor levels are not within the required tolerance, remedial action must be taken. If floor levels cannot be attained, then an immediate report to supervisor is required, with suggested remedial works. If floor levels required cannot be achieved due to older or inadequate equipment, make note on report.

To reset the floor levels reference the XLplus wiring diagram usually contained within the upper landing controller.

9.8 Emergency equipment

- Required standard

Alarm must work and be audible to others with lift electrical supply off. Emergency lighting must work when electrical supply to the lift is isolated. This can be achieved using the lift isolator switch situated within a 5m radius of the upper floor.

All stop switches must work correctly. All stop switches are positioned within the safety chain and when operated will remove all calls and prevent the lift from moving. The four stop switches in question are in the cabin, the pit, the test control (landing control panel) and the landing control panel itself.

- Required action

It is unsafe to leave a lift with no form of emergency communication. If the alarm device cannot be made to work, then consult customer and report to supervisor that lift may have to be removed from service, with details of suggested remedial work.

If any of the stop switches are not operational perform any remedial work necessary. If still not operational inform the customer and supplier that the lift must be taken out of service.

9.9 Safety edges

- Required standard

Mechanical safety edges are installed on the XL Plus; these are situated at the top and bottom of each door aperture on the cabin. Activation of any of the mechanical safety edges must bring the lift to an immediate stop and drop the lift call. Every safety edge must move freely and spring-return to be flush with the cabin floor or roof. Every safety edge must be free of debris and must not be in contact with any other part of the lift (for example, the sling/cabin corners near the end of the safety edges).

- Required action

Any debris must be removed, and free movement of every safety edge must be verified. Any safety edge malfunction (e.g. lift continues to move, call is not dropped or safety edge binds) requires the lift to be taken out of service immediately and reported to the customer and supervisor with recommendations for remedial action.

9.10 Light Curtains

- Required standard

The light curtains are situated at the sides of each door aperture on the cabin. Operation of the light curtain must bring the lift to a controlled stop and remove the lift call. The voice enunciator should inform the user 'Light ray activated, please keep clear of the entrances'.

- Required action

Light curtain failure requires the lift to be taken out of service immediately and report to the customer and supervisor with recommendations for remedial action. If an error is detected within the voice enunciator, inform the customer and supervisor of any remedial work required and the recommendation of the lift to be taken out of service.

9.11 Control panels

- Required Standard

There are two areas to be checked, both the control unit behind the COP (*4.2 Cabin operating panel (COP) removed, pg 4*) and the controls at the upper floor (*4.3 Upper floor landing controls, pg 4*). Contactors and relays when energised should not buzz or be excessively noisy. There must be no indications of excess contact wear, dust underneath relay or flash markings around contactors. Fuse holders must be intact with no damage. Check fuse rating and remove any discarded/used components or shorting wires. All PCB connections must be of sound nature and there must be no visible damage to the board.

- Required action

If a new contactor, PCB or relay is required, record manufacturer, type number, coil voltage, contact arrangement and inform supervisor immediately. If new fuses required, record rating and physical dimension.

If it is not possible to leave the lift in a safe working order, inform the customer and supervisor and advise the lift should be taken out of service.

9.12 Brake operation

- Required standard

After running the lift for the first 2-3 journeys it will become apparent the brakes are working correctly. The lift must start and stop smoothly with out any vibrations or unexpected noises. An indication of correct brake operation will be indicated by a smooth ride. With the upper landing control access removed the brake operation will be audible when the motor starts and stops.

- Required Action

If there is any cause for concern regarding the brake then a thorough investigation of the brake must be made (*13.1 Brake lining, pg 21*). If on inspection of the lining, an immediate correction cannot be achieved, the customer and supervisor must be informed of remedial action and for the lift to be taken out of service.

9.13 Door operation

- Required standard

The door operation is to be as smooth and as quiet as possible. There must be no vibration, juddering or rumbling at any stage of the door cycle. Speed changes in door travel are to be smooth and door closers must be able to close doors from any stopped position.

- Required action

Adjust doors and door closers as necessary to achieve correct operation. This will include altering the speed settings to ensure door closes smoothly and with the correct speed. If there is excessive damage to the door or door closer which are not immediately resolvable make note of required part numbers and inform customer and supervisor on possible lift shut down.

9.14 Landing door locks and beaks

- Required standard

On the first 2-3 journeys of the lift ensure that on reaching floor level the required door opens easily and there is no catching or rubbing of the lock. Once the door has closed ensure the lock comes into operation smoothly and ensure each of the required doors locks correctly. Once outside the lift ensure that no doors are able to be opened when lift is not at required floor level. This test **MUST** be complete at every door as this is a severe safety risk. Ensure that when doors are not closed (i.e. door beaks are not engaged), lift operation is not possible. If the lift is in motion, the opening of the door (with door release key) should stop the lift.

- Required action

If there is no smooth operation of any lock, examine thoroughly to check there is any remedial work that can be carried out (application of lubrication and removal of debris). If there is any issue with lift, lock or beak operation that cannot be resolved immediately, the lift **MUST** be taken out of service immediately. Record component manufacture and part number and inform customer and supervisor.

9.15 Indicators (DDU's and push buttons etc...)

- Required standard

Ensure that all call station and control panel push button halos work correctly. These should light up when a call is put in and stay lit until floor level is reached or call is removed.

Regarding DDU's, all LED's within the dot matrix should be operational. Floor level should also be indicated at the required floor level and when the lift is operational an arrow should indicate lift direction.

- Required action

If it is not possible to fix any of the faulty components, then make a note of type and manufacture and inform supervisor on required remedial work.

9.16 Visual inspection/light clean

- Required standard

It is essential that all areas are visually inspected. This is best done whilst carrying out a light clean. This will also reduce the burden of the thorough clean (*13.2 Thorough clean, pg 22*).

- Required action

Any fault observed is to be rectified. Always repair, adjust, lubricate and clean as a first option. If it is not possible to rectify the fault, inform the customer and supervisor about remedial work and possible lift shut down.

10 MAINTENANCE INSTRUCTION – PHASE 1

10.1 Risk assessment and general lift check

Ensure assessment is still relevant, if hazard has been addressed or new hazard has been identified record as such on assessment. Record that assessment has been reviewed by dating and signing.

As in some instances, the finishing of the lift build may not tie in exactly with the lift handover date. For this reason it is essential that a general lift check is complete as these lifts may have been sat for prolonged periods of time in undesirable conditions.

10.2 Car overload

- Required standard

The first item to check will be to check the load weighing device is set up correctly. Firstly remove the COP (*4.2 Cabin operating panel (COP) removed, pg 4*) and check the weight shown when the car is empty and when there is a known weight in the car. The load weighing controller will be positioned on top of the cabin controller.

To test the car overload is functional; the working load must be changed on the load weighing device (*4.8 Load weighing device – Rated load setup, pg 5*). Set the alarm to approximately 50kg so that the weight of a nominal lift engineer should trip the alarm.

Once this value has been set, stand in lift and attempt to travel upwards. Lift should not move and the overload alarm 'OL' should be displayed on the DDU. Voice enunciation unit will repeat 'Lift overload, would the last passenger please leave the car'. Step out of the cabin, log a call to the next floor and close lift door. Lift should be operational and travel to the required floor.

ON COMPLETION OF OVERLOAD TEST, ENGINEER MUST RE-SET ORIGINAL OVERLOAD VALUE!

- Required action

If the load weighing device is not functional or the device is not calibrated correctly, assess if there is any immediate remedial solution (*4.9 Load weighing device – Calibration, pg 5*). If not, then record manufacturer and part number and inform the supervisor and customer of remedial action and that the lift **MUST** be taken out of service immediately.

10.3 Manual release

- Required standard

It is essential that the manual release for the lift is in sound condition. The manual release procedure should be both displayed clearly within the upper floor controller and in the customers user guide. Follow these instructions ensuring that the system works smoothly and that power is removed from the lift.

- Required action

If the release system is not working correctly and any immediate remedial work cannot be complete, inform the customer and supervisor on future work required and that the lift should be taken out of service.

10.4 Rope connections and wear/stretch

- Required standard

All rope connections must be checked, counterweight, sling and overspeed governor. These connections MUST be of quality nature and secured with a double nut and split pin. Also check rope grips are tight, with the saddle section sitting against the working side of the rope.

Any springs used must have no damage present and be even in compression. Check there is no twisting present in ropes and that any steel work supporting a rope connection must be clear of damage or stress.

Determination when the ropes should have to be discarded must be either,

- According to DIN 15 020, 6 broken wires within a length of 6 x d (36mm overspeed governor and 30mm suspension ropes)
- As specified by supplier, with a reduction of 6% (0.36mm overspeed governor and 0.3mm suspension ropes)

Rope plate should be clearly visible at the rope connection point on the sling pick up beam (*Figure 1 - Rope data plate*).

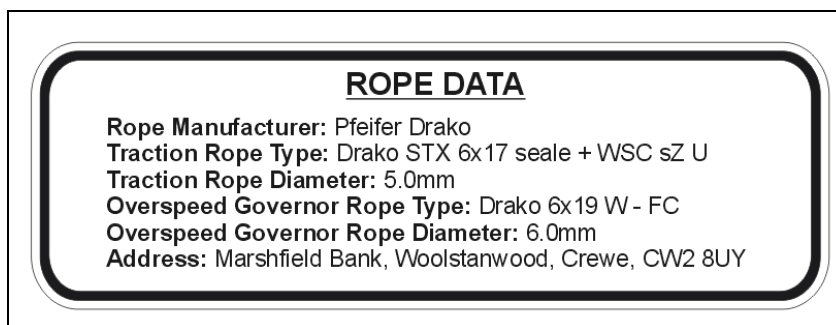

Figure 1 - Rope data plate

Finally, check for rope stretch. The ultimate limit switch should operate before the counterweight comes into contact with the pit buffer.

- Required action

If there are any nuts, rope grips or split pins absent replace if possible and make note on log card. Clear any light corrosion on terminations. If any spring, eyebolts etc... are damaged make note of manufacture and part number and inform supervisor and customer on required remedial work.

If any ropes are not to the required standard, terminals are pulling through steel work or connections have excessive corrosion the customer and supervisor must be informed that the lift will need to be taken out of service immediately.

If counterweight comes into contact with pit buffer before the ultimate limit switch operates, it is possible to remove the counterweight packers situated at the bottom of the counterweight. If all packers are removed and problem still occurs, inform customer and supervisor that lift should be taken out of service and suspension ropes should be replaced.

10.5 Earth bonding, insulation and electrical

- Required standard

Ensure that all earth bonds are present and that any terminations are secure.

- Required action

If a lift fails to be sufficiently earthed, this will result in a substantial risk to the user. If immediate earth bonding cannot be achieved then the lift must be taken out of service and the customer and supervisor is to be informed on the future remedial work.

11 MAINTENANCE INSTRUCTION – PHASE 2

11.1 Roof top

- Required standard

Important note: Persons are not permitted to stand on the car roof. On access of the ceiling (4.4 Ceiling removed, pg 5), check all light fittings and check any loose electrical terminations or signs of overheating. The engineer must be able to access roof top and replace roof top with ease and ceiling must be secure once returned to normal operating position.

- Required action

If any terminals are loose, re tighten and assess the cause. If there is any damage to any component, record manufacturer and part number and inform supervisor and customer of any remedial work required. If there is any issue with ceiling access, carry out any remedial work required and inform supervisor and customer if any further remedial work is required.

11.2 Upper shaft work

- Required standard

Important note: Persons are not permitted to stand on the car roof. On access of the upper shaft work (4.4 Ceiling removed, pg 5), firstly check the traction sheave to ensure there is no indication of cracking and the keyway has no signs of any movement. Ropes must be sitting at the same depth within grooves and there must be no signs of fluting or riffling.

Check all fixings, guides, sheave guard, overspeed governor and horizontal member. Look for any unexpected debris. Ensure ropes pass through bedplate without clashing with any of the metal work.

- Required action

If there is any damage, looseness in keyway or excessive groove wear, inform supervisor and customer immediately and advise on required remedial work. Assess whether to advise customer on possible lift shut down.

Re-tighten any loose fixings and if there is any unexpected debris found around bedplate, investigate both. If there is any clash with ropes and metal work, carry out any immediate remedial work. If not resolvable, inform supervisor and customer on further remedial work required.

11.3 Drive shaft bearings

- Required standard

Important note: Persons are not permitted to stand on the car roof. Access to the upper shaft work is gained by removing the cabin (4.4 *Ceiling removed*, pg 5)

The main drive shaft support bearings (2 off), located on the bedplate at the top of the shaft, need to be checked for re-lubrication. The bearings are considered to be lubricated for life, but due to differing operating conditions (temperature, vibration, loads etc) they need to be checked to ensure the moving elements of the bearing are lubricated. Firstly, check for excessive noise and vibration while running the lift (remove the motor access panel, located in the upper landing controller, for a clearer examination of the noise). Also, assess the bearings for general wear/degradation and check for excessive grease seeping out around the bearing seals (a small amount is acceptable and will not require attention).

Note: Do not attempt to tighten the bearing collar fixings. Attempts to tighten the fixings could result in deformation of the collar. If it is suspected that the shaft has moved in the bearings, first check that the fixings securing the bearing housings to the bedplate are secure. Following this, technical assistance should be sought due to the specific procedure required to refit the bearings to the shaft.

- Required action

If it is determined that the bearings need relubricating, isolate the power to the lift and gain access to the upper shaftwork (4.4 *Ceiling removed*, pg 5). Using a grease gun and SKF LGWA 2, LGMT 2, LGMT 3 or equivalent grade grease, slowly press in the lubricant into the bearing via the grease nipple located on top of each housing. A flexible extension hose may be required to access the grease nipples (dependant on headroom). Stop pressing the grease into the bearing as soon as fresh grease starts escaping out of the seal. Avoid excess pressure as this can damage the seals.

If the remedial work cannot be completed, or the bearings need replacing, inform the customer and supervisor that the lift will need to be taken out of service immediately and advise on the work required.

11.4 Ultimate limit switch

- Required standard

The ultimate limit is located on the lift sling. Call the lift up to upper landing using upper landing call station and on arrival of lift remove COP and rear walls (4.5 *COP and rear wall removed*, pg 5).

Using the push-pull switch located on the din rail assembly within the upper control unit, switch the lift to slow speed by pushing the switch in. Use the test control (4.3 *Upper floor landing controls*, pg 4) to operate the lift upwards at slow speed. Lift should stop before clashing with bedplate at approximately 50mm above floor level. When the lift has come to a halt, use the test controls to operate the lift downwards, the lift should not move as the ultimate limit switch will be engaged.

To move the lift downwards, link out G2A to G3 on the controller. Once the ultimate limit pin has moved away from the ultimate limit ramp, reset switch 'A' and remove link from G2A to G3 (Figure 2 - *Ultimate limit switch*).

- Required action

If lift comes to a halt before the ultimate limit stops the lift, look the following areas.

- If the counterweight is coming to rest on the buffer before the switch activate, check rope stretch (10.4 *Rope connections and wear/stretch*, pg 14).
- If the sling clashes with the bedplate before the switch activates. Check the position of the ultimate limit ramp.
- If the switch pin is activating but not cutting power to the motor, check wiring and carry out any immediate remedial work.

If the ultimate limit switch is still not functional record manufacturer and part number and inform customer and supervisor on further remedial work and recommend on lift shut down.

It is of up most importance to remove this link once check is complete!

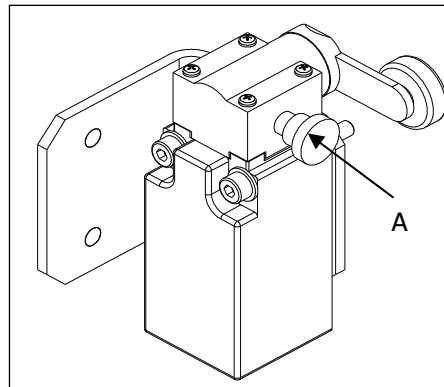

Figure 2 - Ultimate limit switch

11.5 Safety gear and overspeed governor

- Required standard

Before activating the safety gear, verify that they are set up correctly on the guides and there is a gap of 2.0mm between the safety gear and the back of the guides (*Figure 3 - Safety gear setup*).

At full speed, activation of the overspeed governor (*4.6 Overspeed governor tests, pg 5*) must cut power to the motor and safety chain at G2. Full safety gear activation does not need to be complete in the annual check. This can be complete in the 5 year check.

Once engaged, enter the lift and check behind the rear wall (*4.5 COP and rear wall removed, pg 5*) to see that the safety gear on each side has began to engage. These should not be fully engaged at this stage as the motor will have cut movement of the lift before full engagement.

- Required action

If for any reason the safety gear has not engaged, investigate possible cause. This may be due to a linkage error at any point between the overspeed activation to the safety gears themselves. If only one of the safety gears are engaged, ensure that these are set up correctly (*Figure 3 - Safety gear setup*). Whilst the safety gear activation plate 'A' is lined up in the middle of the access slot, the safety gear roller 'B' should be set up in the centre of each of the safety gears.

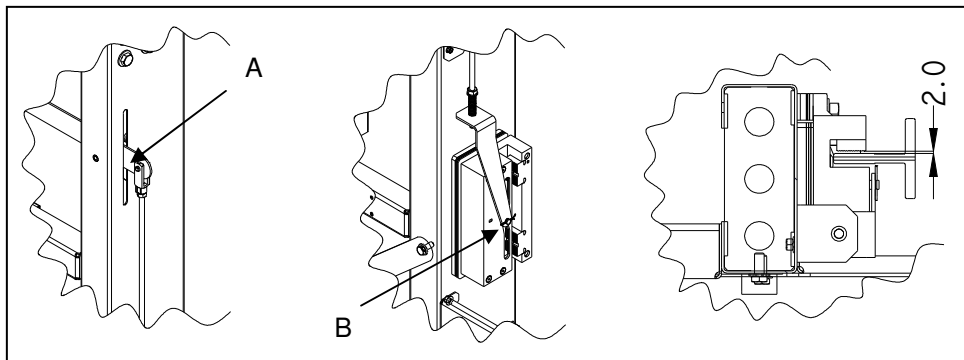

Figure 3 - Safety gear setup

11.6 Encoder and timing belt

- Required standard

The general function of the encoder and timing belt will have been assessed in the checking of the floor level. If floor levelling is correct, check all fixings are secure and belt is running smoothly within pulleys.

Ensure that timing belt brackets are fixed securely and the encoder cable is clear from moving parts and free from damage.

- Required action

Tighten any loose fixings and carry out any immediate repair work. If there is any excessive damage to any component record manufacturer and part number and inform customer and supervisor on further remedial work.

11.7 Guides and fixings

- Required standard

With COP and rear wall removed (*4.5 COP and rear wall removed, pg 5*), travel the whole length of the shaft checking all counterweight and car guide fixings are secure. Check for any excessive damage to guides and that all joints are of quality nature.

With the rear wall removed check the thickness of the slider inserts connecting the sling to the guides (*Figure 4 - Car slider inserts*). The correct thickness should be 9.7mm. The minimum thickness of this insert should be 6.7mm (a reduction of 3.0mm).

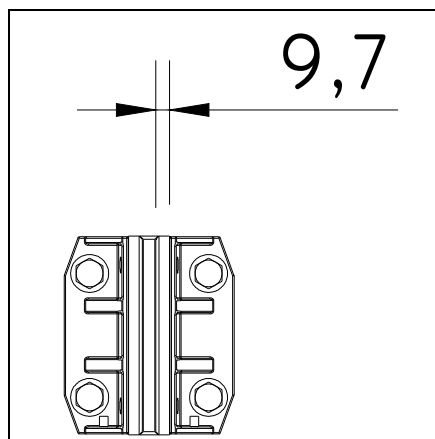

Figure 4 - Car slider inserts

- Required action

Tighten any loose fixings and replace where necessary. Investigate cause for missing fixings or excessive wear and make note. If there is any excessive damage to any guide, inform customer and supervisor on remedial work and possibility that lift will need to be taken out of service.

Dress guides where necessary.

If for any reason the slider inserts are below the minimum 6.7mm then new inserts must be ordered and replaced when possible. Inform the customer and supervisor on the possibility of taking the lift out of service when looking at lift cabin clearances.

11.8 Trailing cable and chain

- Required standard

Chains and cable must have no twisting or kinks and all anchorage points must be secure. There must be no surface wear, cracks or splits on any point of the cable and they must run clear of all fixed parts of the lift installation. Access to the cables can be made through the rear wall of the cabin (*4.5 COP and rear wall removed, pg 5*)

- Trailing cable and chain – Required action

If new cables or chains are required make note of type and length and inform customer and supervisor on remedial work.

11.9 Sling and car fixtures

- Required standard

With COP and rear wall removed (*4.5 COP and rear wall removed, pg 5*), check all fixings are in place and secure. Ensure all contact washers are in places and locking nuts are in place at the bottom of the cabin uprights. Check for damage or excessive wear to sling.

- Required action

Tighten any loose fixings, replace where necessary and investigate cause for missing fixings. If it is not possible to replace missing fixings or there is any excessive damage to the sling, inform customer and supervisor on remedial work and possibility that lift will need to be taken out of service.

11.10 Gearbox/motor

- Required standard

Important note: persons are not permitted to stand on car roof. Gearbox/motor can be accessed through manual release access panel (*4.3 Upper floor landing controls, pg 4*) and through cabin ceiling (*4.4 Ceiling removed, pg 5*). Check torque arm is secure and general appearance of unit is good. Check for oil leaks in and around gearbox/motor. Check for any unexpected noises or vibrations on gear unit, motor and surrounding areas. Check to see if fan is working quietly and is drawing air over the motor. Look for any discolouration and any extreme temperatures, indicating over heating.

- Required action

The cause of any overheating / vibrations must be investigated, inform customer and supervisor on any remedial work. If oil levels are low, investigate cause. If problem cannot be fixed inform customer and supervisor on any remedial work and if the lift will need to be taken out of service. If oil leak fixed, top up oil with Synthetic oil type Telium VCF 320 or equivalent.

12 MAINTENANCE INSTRUCTION – PHASE 3

12.1 Counterweight

- Required standard

Before entering the pit, ensure the pit stop is activated. On completion of test ensure pit stop is de-activated.

All fixings on the counterweight and guard should be secure and present. Both should be clear from damage. Only a quick examination of the rope connections is required as the full maintenance check will be complete at a different phase (*10.4 Rope connections and wear/stretch, pg 14*).

Whilst in the pit check the counterweight sliders (*Figure 5 - Counterweight slider*). The original thickness of the slider should be 4.00 and this should not be less than 2.0mm.

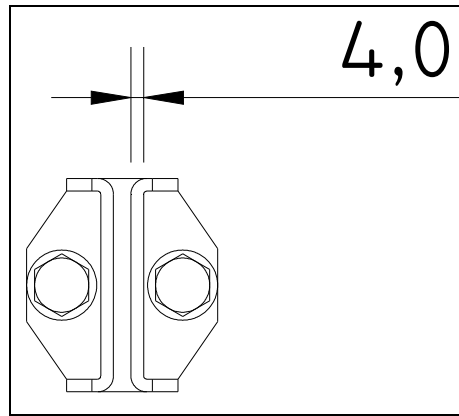

Figure 5 - Counterweight slider

- Required action

Tighten any loose fixings and replace where necessary. Investigate cause for missing fixings and make note. If the guard has signs of any marks, investigate the cause, this may be due to the sling clashing with the guard or the guard clashing with the counterweight. If unsolvable inform customer and supervisor on remedial work and possibility that lift will need to be taken out of service.

12.2 Pit buffer

- Required standard

The buffers must be checked for excess damage and loose fixings. Before entering the pit, ensure the pit stop is activated. On completion of test ensure pit stop is de-activated.

- Required action

Tighten any loose bolts and take manufacturer and part number if there is excess damage to buffer. Inform supervisor and customer on further remedial work required.

12.3 Tension Pulley

- Required standard

Take lift to top floor and return to ground floor leaving the car at top floor. Enter the pit using the door release key and activate the pit stop.

Check tension pulley for any debris and loose fixings. Also check tension pulley sits within tension indicator (*Figure 6 - Tension pulley setup*). Activate switch, de-activate pit stop and return to cabin. Access control panel (*4.2 Cabin operating panel (COP) removed, pg 4*) and check safety chain, chain should be lit to G1 only and feed from G1A to G1B will be lost. Return to ground floor and de-activate tension pulley switch.

- Required action

Tighten any loose bolts and investigate any cause of debris. Investigate any cause for lost tension within governor rope and complete any immediate remedial work available. If tension cannot be reached within rope lift MUST be taken out of service and the customer and supervisor must be informed of future remedial work.

If and part

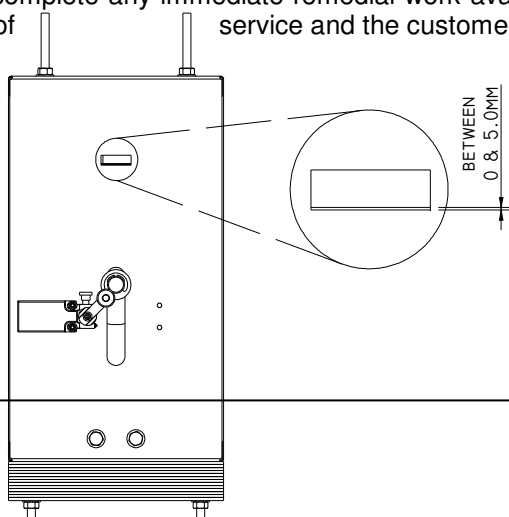

tension pulley switch needs replacing, record manufacturer number and inform customer and supervisor on remedial necessary. Lift MUST be taken out of service.

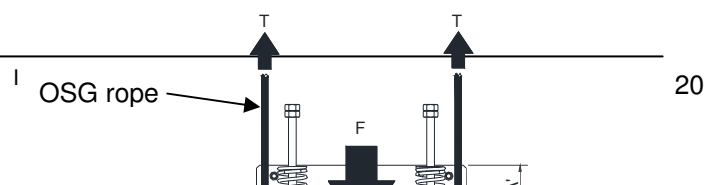

Figure 6 - Tension pulley setup

Figure 6 shows the working of the tension pulley. Beneath the front plate (removed for clarity in right hand image) two compression springs apply a downwards force (F) onto the pulley, this in turn places tension (T) into the governor rope (i.e. the more the springs are compressed or the smaller dim 'A' becomes, the more tension is placed in the rope). The top of the pulley bracket must lie within the tension indicator slot to ensure correct tension in the rope.

12.4 Cabin floor

- Required standard

Bring the cabin to approximately 2000mm above floor level and open door using lock release key. On entering the cabin press the pit stop switch to stop lift car movement. Remove the fixing screws from the underside of floors. Exit pit and move cabin down to 300mm above floor level. Remove cabin floor from car and check component integrity. Flooring should be free from damp patches, cracks or excessive wear.

- Required action

If any damage is identified cabin floor must be replaced. Inform customer and supervisor on remedial access and advise that lift should be taken out of service.

12.5 Pit clean

- Required standard

Before entering the pit, ensure the pit stop is activated. Ensure pit is clear from dust and debris, ensuring pit stop is de-activated on completion of clean.

13 MAINTENANCE INSTRUCTION – PHASE 4

13.1 Brake lining

- Required standard

As well as brake functionality, the actual brake lining must be checked for excessive wear. Access the brake (4.5 COP and rear wall removed, pg 5) and check the brake lining gap and also for any excessive wear (0 Brake assembly, pg 5).

- Required action

If the air gap within the brake requires adjusting, this can be adjusted until it is acceptable. If for any reason the brake cannot be brought up to a suitable standard the customer and supervisor must be informed on lift shut down.

13.2 *Thorough clean*

- Required standard

Within the thorough clean it gives the engineer both a perfect chance to give everything within the lift a visual inspection and also visually bring the lift up to the required standard.

14 5 YEAR MAINTENANCE CHECKS

14.1 *Gearbox/motor detailed check*

- Required standard

In addition to the standard annual check a 5 year may be required. This will involve checking the backlash and thrust of the motor. For this check the load must be removed from the motor by following these steps.

- Place packer beneath counterweight.
- Bring cabin to top floor using test control. Activate slow speed on nearing the top as counterweight will come to rest on packer.
- Access the rear wall of cabin (*4.5 COP and rear wall removed, pg 5*)
- Using block and tackle, connect from the lifting bar to the sling and take the tension off the ropes.
- Use secondary safety brackets to fix sling back to shaft.
- Remove motor coupling from motor shaft.
- ENSURE LOAD IS TAKEN ON BLOCK AND TACKLE AND SAFETY BRACKETS.

With the load removed a standard check on the backlash and thrust.

- Required action

If the thrust or backlash falls out of the required standard then a new motor/gearbox must be ordered and the customer and supervisor must be informed that the lift should be taken out of service.

14.2 *Earth bonding, insulation and electrical visual*

- Required standard

Ensure lift is first isolated and then check that metalwork enclosing live components, lift framework, lift carriage and cabin metalwork is earth bonded to the main earthing terminal by earth protective conductors and of a value not greater than **0.5Ω**.

Power circuits (select 500v test on meter). Turn off landing control station RCD. Test insulation to earth from both the L & N terminals on the RCD 'supply' side. **Value should be greater than 5MΩ?**

Power circuits (select 500V test on meter). Turn off carriage mains isolation switch & unplug PL26 from the trailer PCB. Test insulation to earth from both L & N terminals on the disconnected plug. **Value should be greater than 5MΩ?**

Check to see if RCD is present and operational and observe if the mains and control circuit voltage are within the required tolerance (Mains $240 \pm 14.5V$, control circuit $27 \pm 3Vdc$).

- Required action

If a lift fails to be sufficiently earthed or safety insulated, this will result in a substantial risk to the user. If immediate earth bonding cannot be achieved then the lift must be taken out of service and the customer and supervisor is to be informed on the future remedial work.

Where there is a discrepancy in voltage recordings, an investigation must be complete on probable cause. Dependant on whether a solution can be found, it may be advised that the lift should be taken out of service. The customer and supervisor should be informed of future remedial work.

If a new RCD or any other electrical component is required, record manufacturer, type number and inform customer and supervisor immediately.

14.3 Safety gear and overspeed governor (Full safety activation required)

- Required standard

Before activating the safety gear, verify that they are set up correctly on the guides and there is a gap of 2.0mm between the safety gear and the back of the guides (*Figure 3 - Safety gear setup*).

To achieve full safety gear activation, a link must be place between G2 to G2A. This will prevent the safety gear monitor switch from cutting power to the lift.

At full speed, activation of the overspeed governor (*4.6 Overspeed governor tests, pg 5*) must bring the lift to an immediate stop.

Once engaged, enter the lift and check behind the rear wall (*4.5 COP and rear wall removed, pg 5*) to see that both sets of safety gear have engaged and that the lift car is secure.

- Required action

If for any reason the safety gear has not engaged, investigate possible cause. This may be due to a linkage error at any point between the overspeed activation to the safety gears themselves. If only one of the safety gears are engaged, ensure that these are set up correctly (*Figure 3 - Safety gear setup*). Whilst the safety gear activation plate 'A' is lined up in the middle of the access holes, the safety gear roller 'B' should be set up in the centre of each of the safety gears.

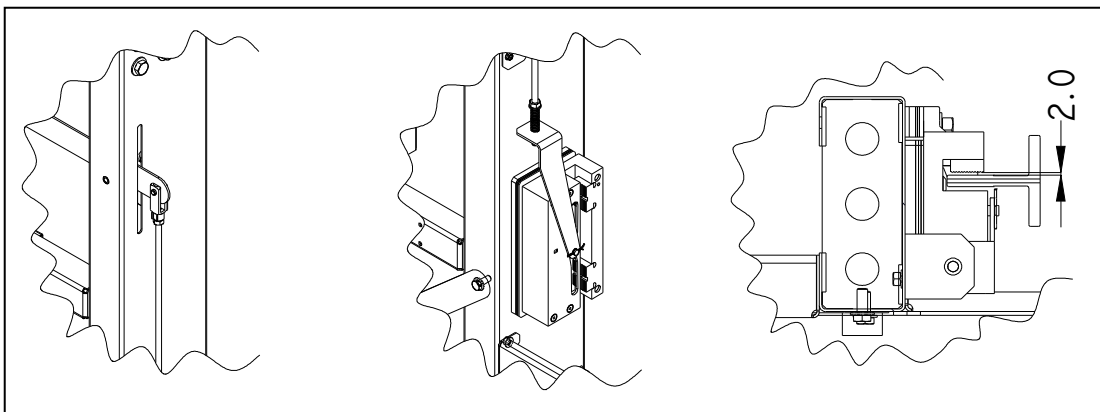

Figure 7 - Safety gear setup

15 ADDITIONAL CHECKS

15.1 Autodialer

- Required standard

The autodialer must dial out correctly, and both the microphone and the speaker must be clear to the user and the operator. Before testing the autodialer, acquire the programmed number and inform the operator about the following test.

If autodialer is installed with induction loop, perform all the necessary tests to ensure system is working correctly.

- Required action

Carry out any immediate remedial work required, wiring or re-programming the unit. Access can be gained through the COP (4.2 Cabin operating panel (COP) removed, pg 4). If further work is required, inform supervisor and customer and record any manufacturer details and part numbers necessary.

15.2 Telephone

- Required standard

The telephone must be free from damage and clear at both ends of the line.

- Required action

Carry out any immediate remedial work required, wiring or re-programming the unit. Access can be gained through the COP (4.2 Cabin operating panel (COP) removed, pg 4). If further work is required, inform supervisor and customer and record any manufacturer details and part numbers necessary

15.3 Intercom

- Required standard

The intercom must connect correctly, and both the microphone and the speaker must be clear to the user and the operator. Before testing the intercom, inform operator of the subsequent test.

- Required action

Carry out any immediate remedial work required. Access can be gained through the COP (4.2 Cabin operating panel (COP) removed, pg 4). If further work is required, inform supervisor and customer and record any manufacturer details and part numbers necessary

15.4 Power door operator

- Required standard

The door operation is to be as smooth and as quiet as possible. There must be no vibration, juddering or rumbling at any stage of the door cycle. Doors are to come to halt at open and closed points quietly and not slam into uprights. Speed changes in door travel are to be smooth and happen at the correct part of the door travel.

- Required action

Adjust doors and door closers as necessary to achieve correct operation. This will include altering the speed settings to ensure door closes smoothly and with the correct speed.

If there is excessive damage to the door or door closer which are not immediately resolvable make note of required part numbers and inform customer and supervisor on possible lift shut down.

Details on the operator setup can be found in the electrical manual, this should be stored in the upper landing control panel (4.3 Upper floor landing controls, pg 4).

15.5 Fire alarm shut down

- Required standard

If selected this option will ensure the lift is brought down to ground floor on the input of the building fire alarm. Once at ground the lift should announce that the user can exit the lift using the ground floor button. At this point the only function still effective will be the operation of the ground floor button situated in the cabin.

- Required action

If for any reason this function does not work as described, carry out any immediate remedial or inform the supervisor and customer on any future work required.

15.6 UPS

- Required standard

With power cut to lift, the cabin must be able to run down to ground floor powered by the UPS. Different levels of emergency power may be supplied at the UPS, from only completing one journey to ground floor or completing numerous journeys. Check lifts documentation for this information

- Required action

If for any reason this function does not work as described, carry out any immediate remedial or inform the supervisor and customer on any future work required.

16 APPENDIX A

16.1 Cabin operating panel (COP) removed

- Using 'COP ACCESS' key, unlock control panel.
- Pull panel towards user.
- Lift panel off pivot bar to remove being careful not to damage controller or cables.
- Follow instruction in reverse order to return control panel to normal state.
- Ensure lock is secure and cables are free when replacing panel.

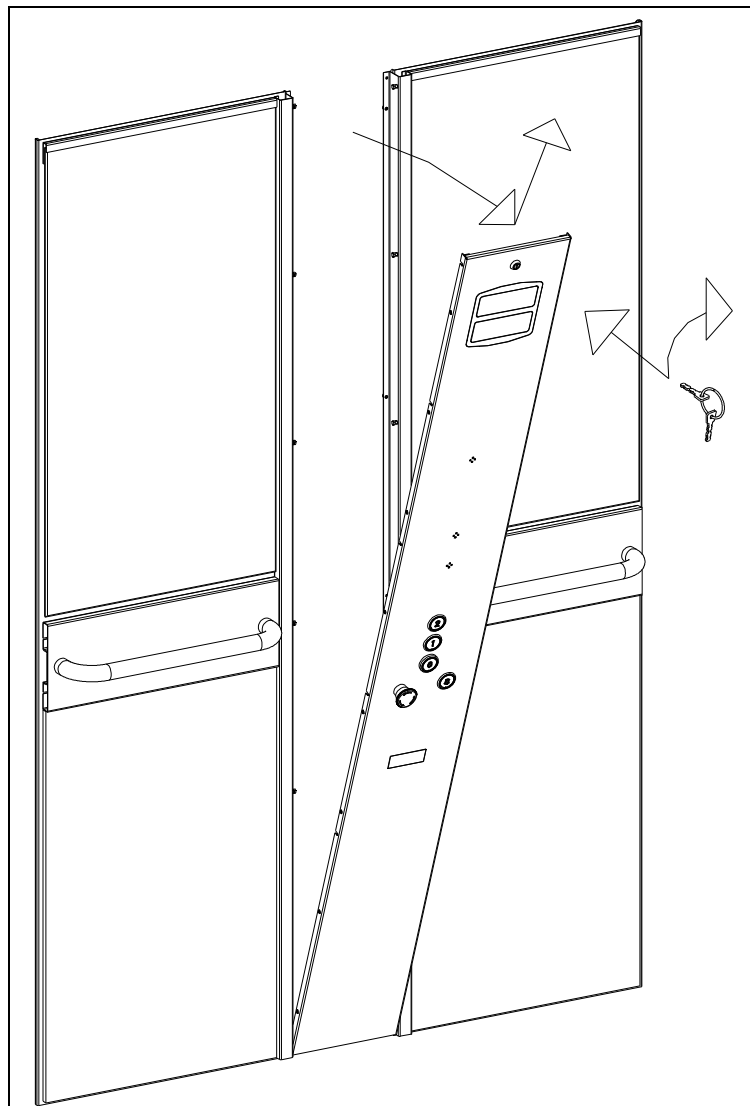

Figure 8 - COP access

16.2 Upper floor landing controls

- Using 'UPPER FLOOR LANDING CONTROL ACCESS' key, unlock access panel.
- Pull panel towards user.
- Lift panel upwards to remove.
- Follow instruction in reverse order to return panel to normal state.

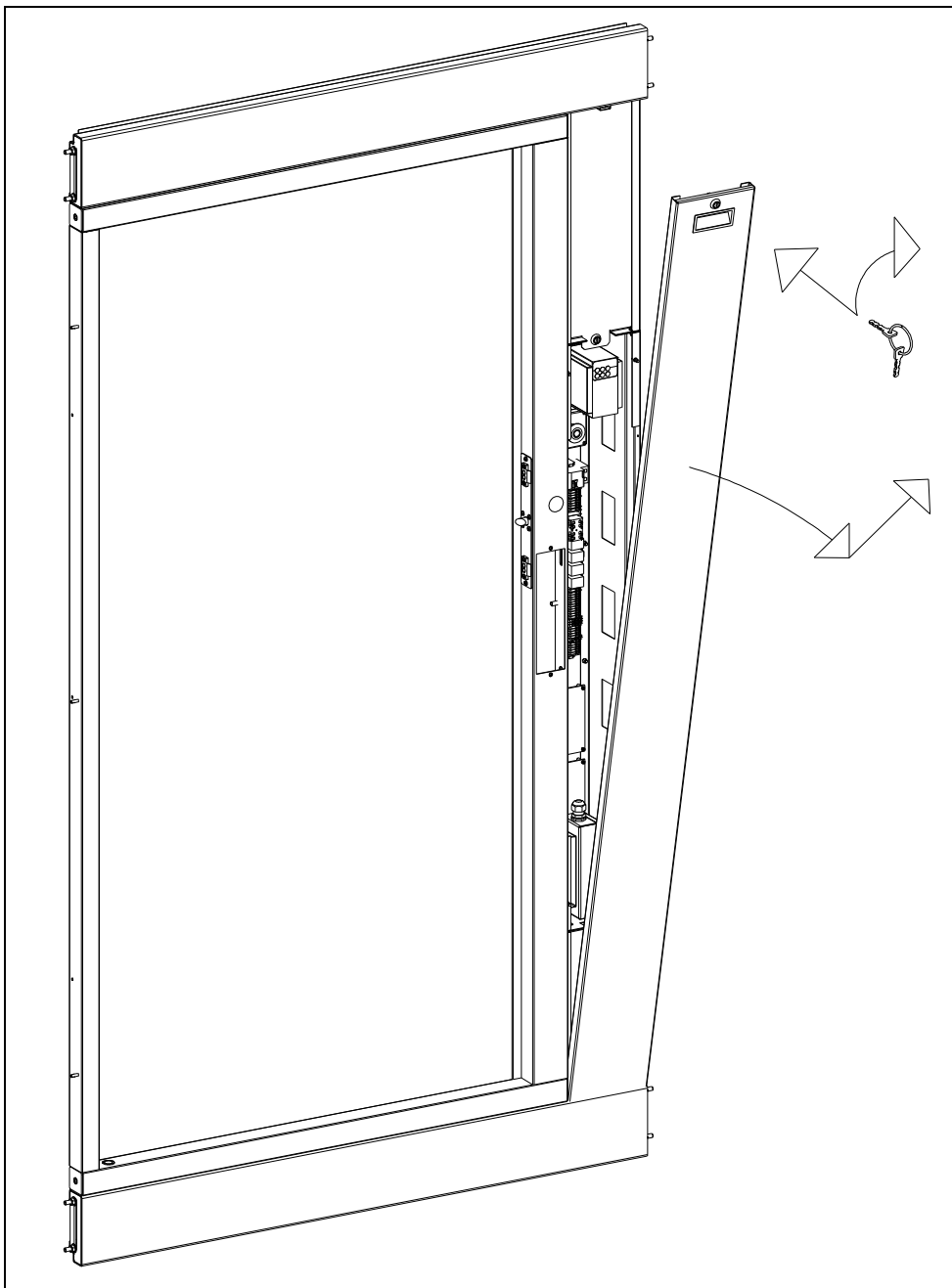

Figure 9 - Upper floor landing controls

16.3 Ceiling removed - Important note: persons are not permitted to stand on car roof

- Using 'CEILING ACCESS' key, unlock ceiling panel.
- Pull ceiling downwards to access (suction cups maybe be required to release).
- Swing ceiling downwards until hanging vertically.
- Follow instruction in reverse order to return ceiling to normal state.
- Ensure lock is secure and ball clips in corners are engaged.
- If access is required above the lift car simple remove centre board and top sling brace. There will be no fixings to remove from the centre board.
- ENSURE CEILING DOES NOT TWIST WHEN LOWERING!

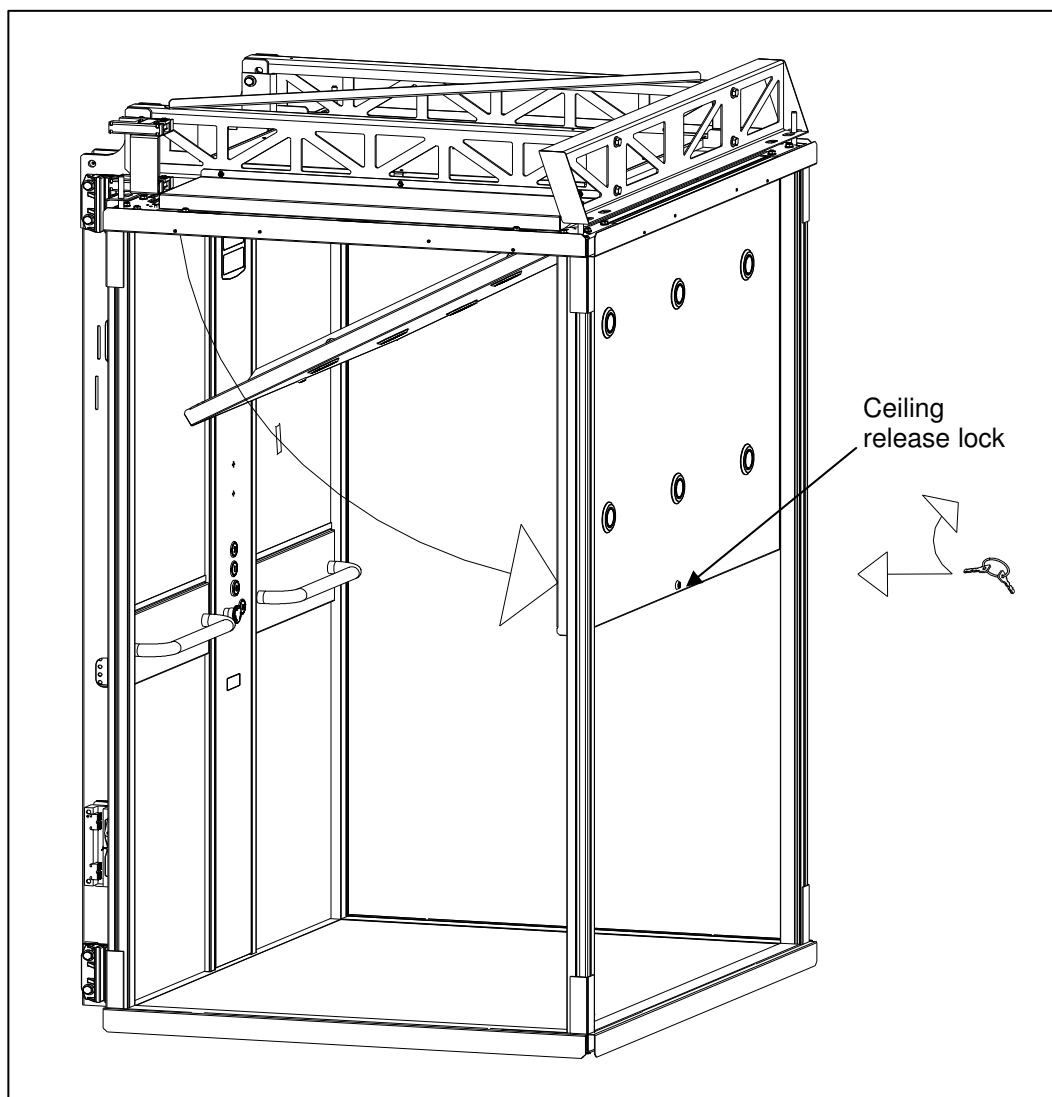

Figure 10 - Ceiling removed

16.4 COP and rear wall removed

- To access behind the rear wall, firstly the COP must be removed (*4.2 Cabin operating panel (COP) removed, pg 4*)
- Once removed the COP trim can be taken out (*Figure 11 - COP trim being removed*). Fixings on the trim's can easily be accessed.
- Using a suitable rated set of suction cups, lift the mirror upwards and remove. The weight of the individual mirror is approximately 7kg.
- Remove upper mirror channel.
- In the last stage the whole wall can be taken out in one assembly. Shown below is a wall from a custom cabin (wallboard, dado rail and handrail).
- Lift the wall upward and out of the aluminium extrusion.
- Pull wall assembly towards user and drop down out of top aluminium extrusion.
- To reassemble wall and COP reverse instruction.

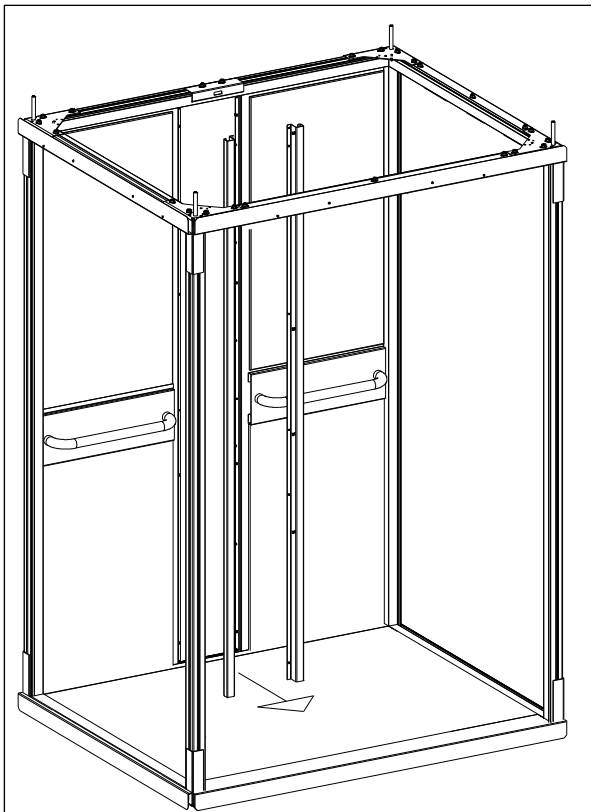

Figure 11 - COP trim being removed

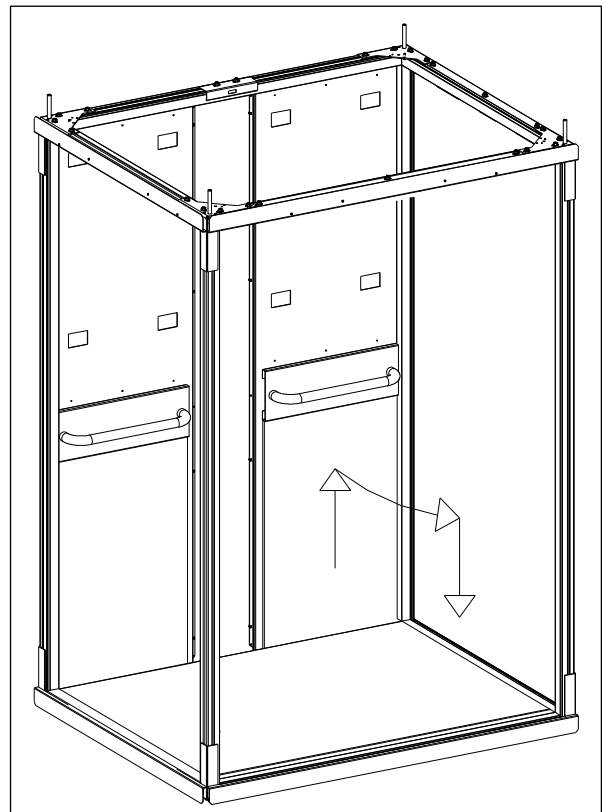

Figure 12 - Rear wall being removed

17 APPENDIX B

17.1 Brake lining

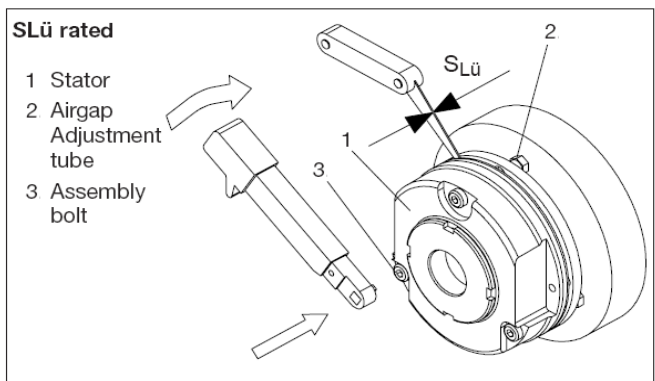
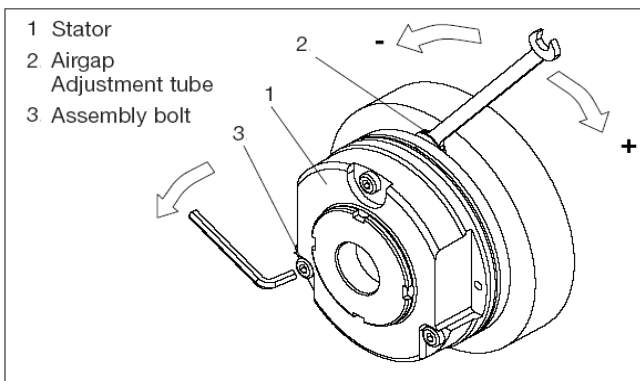
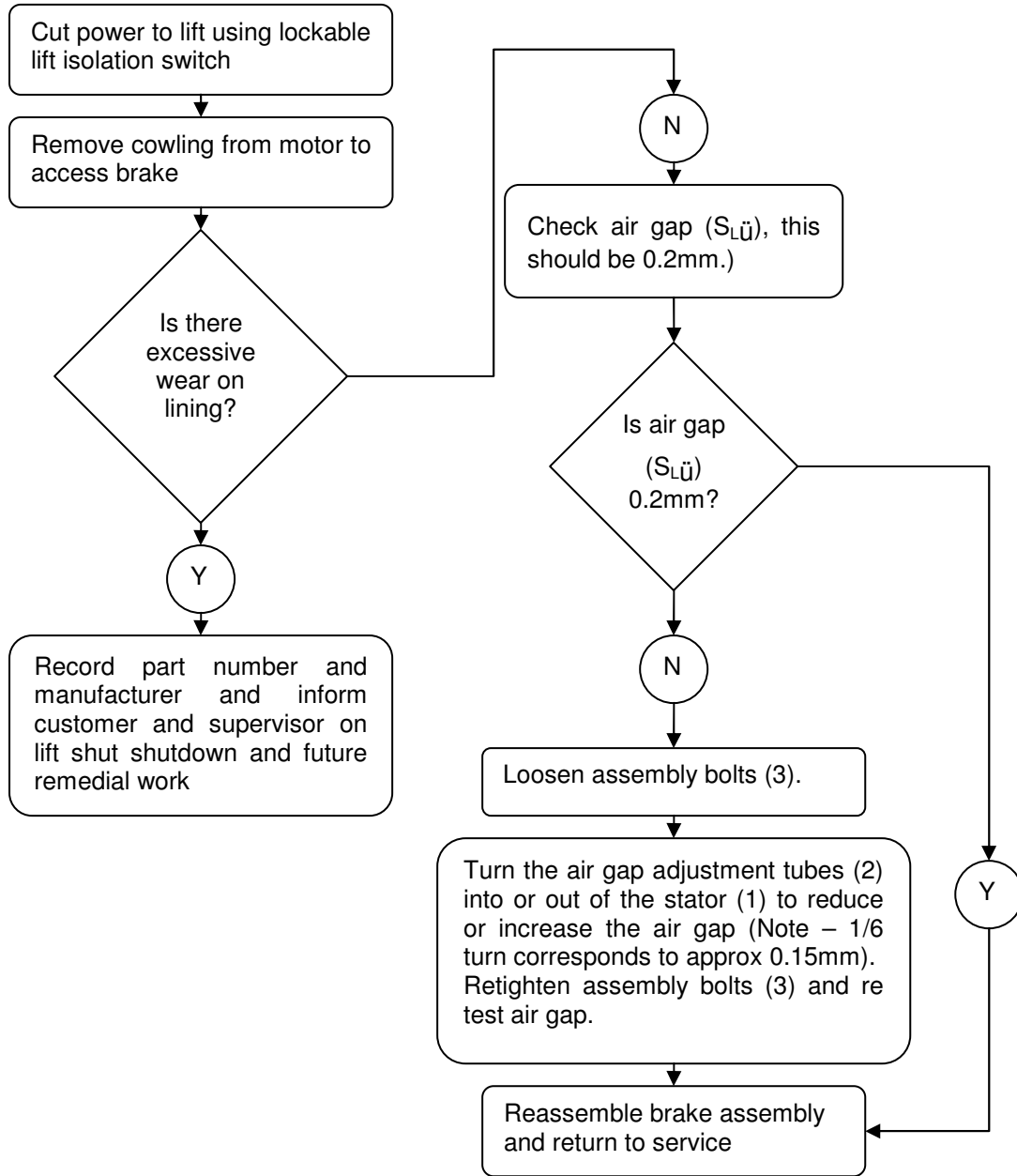
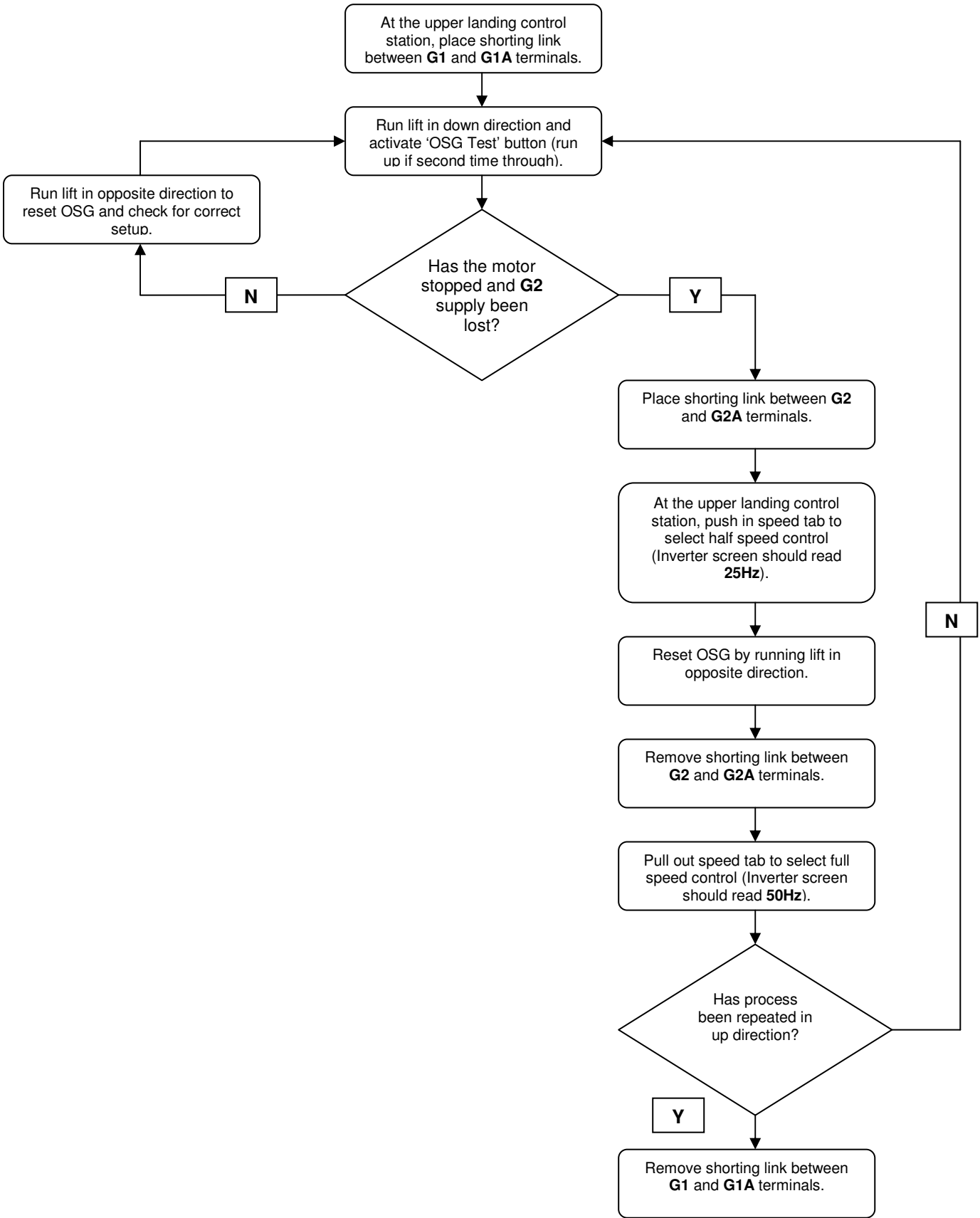
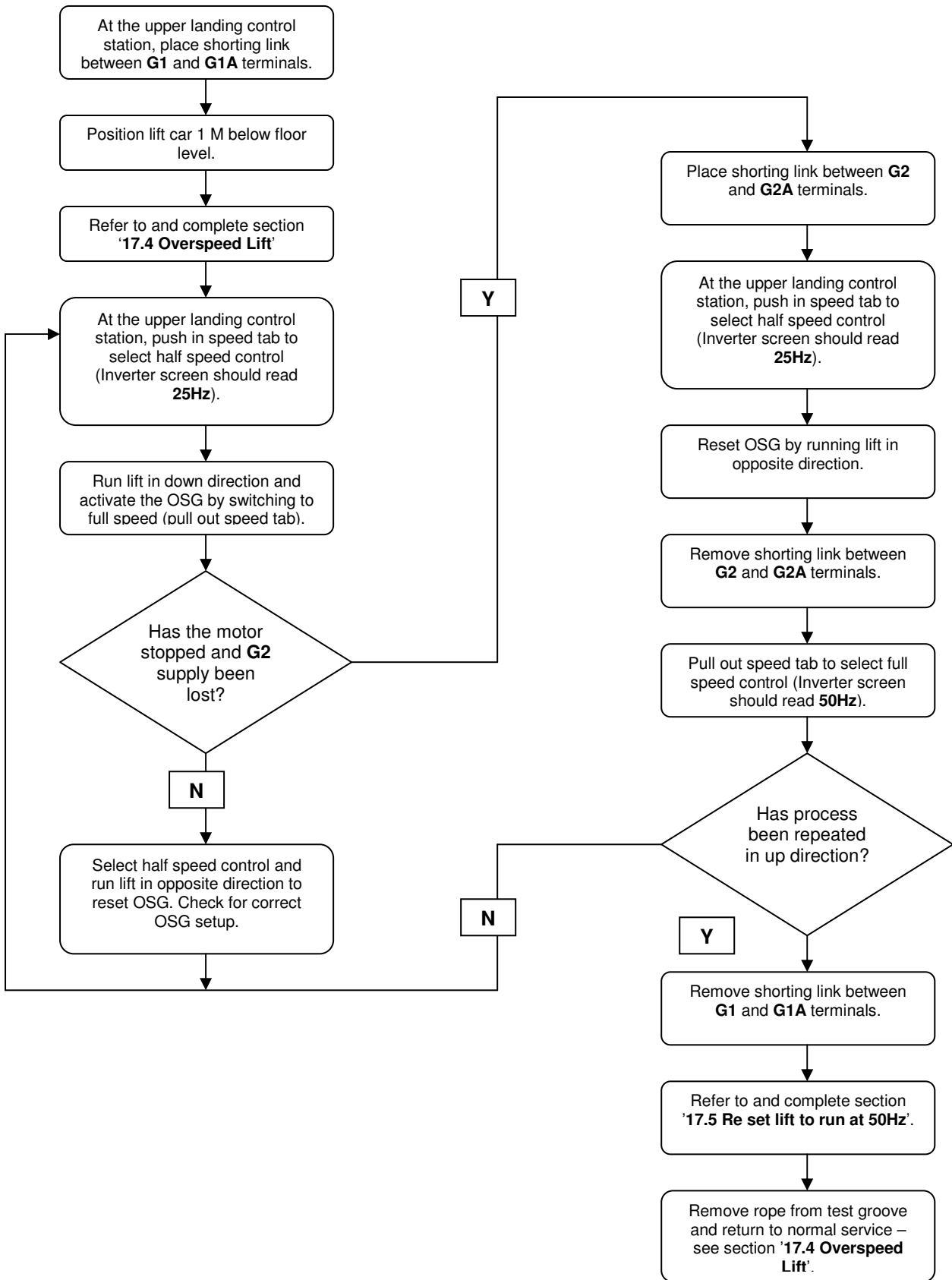

Figure 13 - Brake assembly

17.2 Overspeed governor activation tests – for contracts with remote test control OSG activation button only (see 17.3 for contracts without remote OSG activation).



17.3 Overspeed governor activation tests – for contracts without remote test control OSG activation button only (see 17.2 for contracts with remote OSG activation) .



17.4 Overspeed lift

Depending on when the lift was installed, an overspeed governor test switch may be present. This switch can be used to activate the overspeed governor remotely (from the test controls box within the upper landing controller)

Access the upper landing controller and check the test controls box located near the bottom of the electrical enclosure. If there is a button marked 'OSG test' then the lift has been fitted with remote activation.

To activate the overspeed governor using this button, simply drive the lift in the required direction and press and hold the 'OSG test' button until safety gear activates (Ensure that G1 – G1A has been linked out).

If the lift is not fitted with the remote activation then follow the flow diagram below to activate the overspeed governor manually.

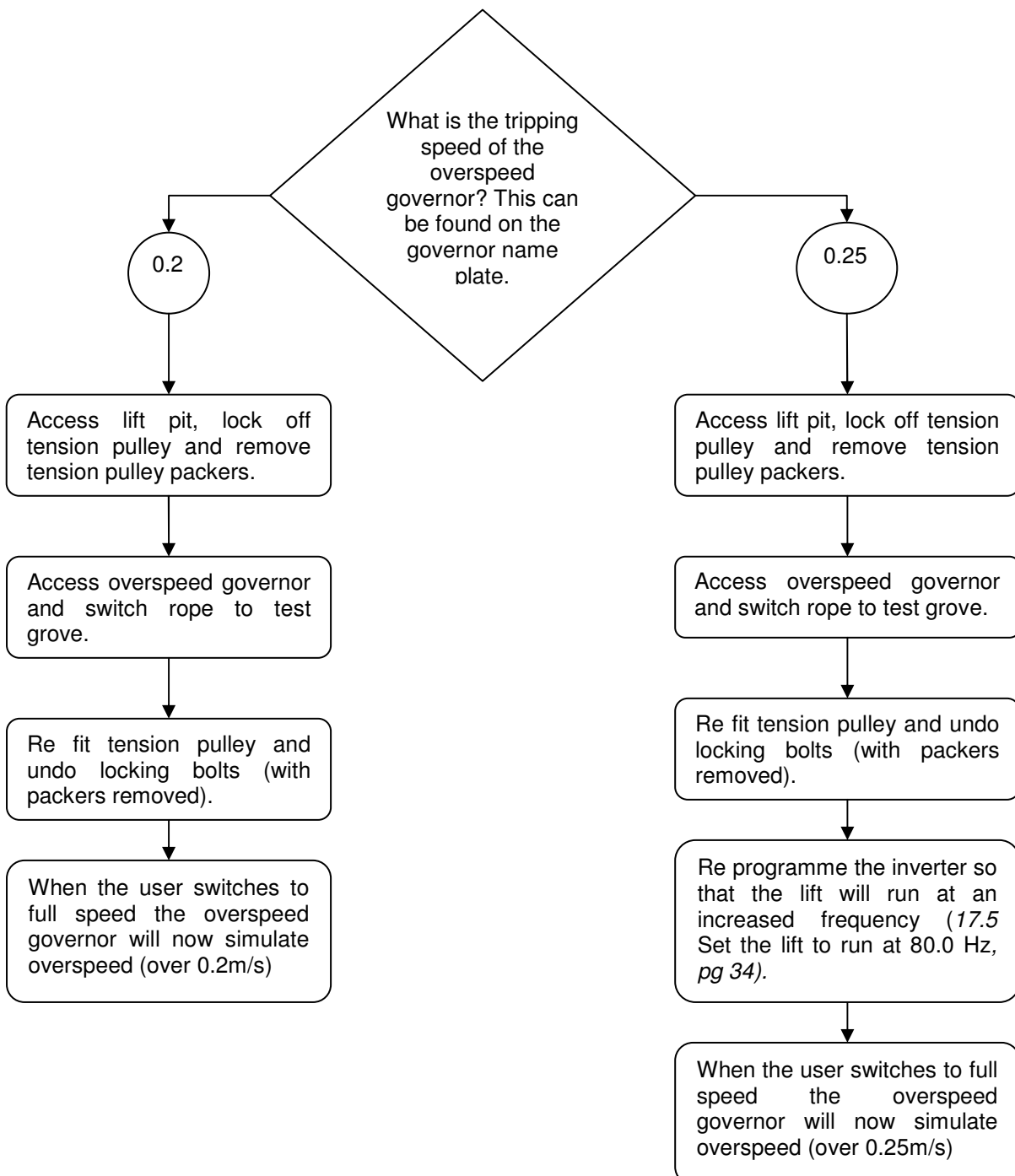

17.5 Set the lift to run at 80.0 Hz

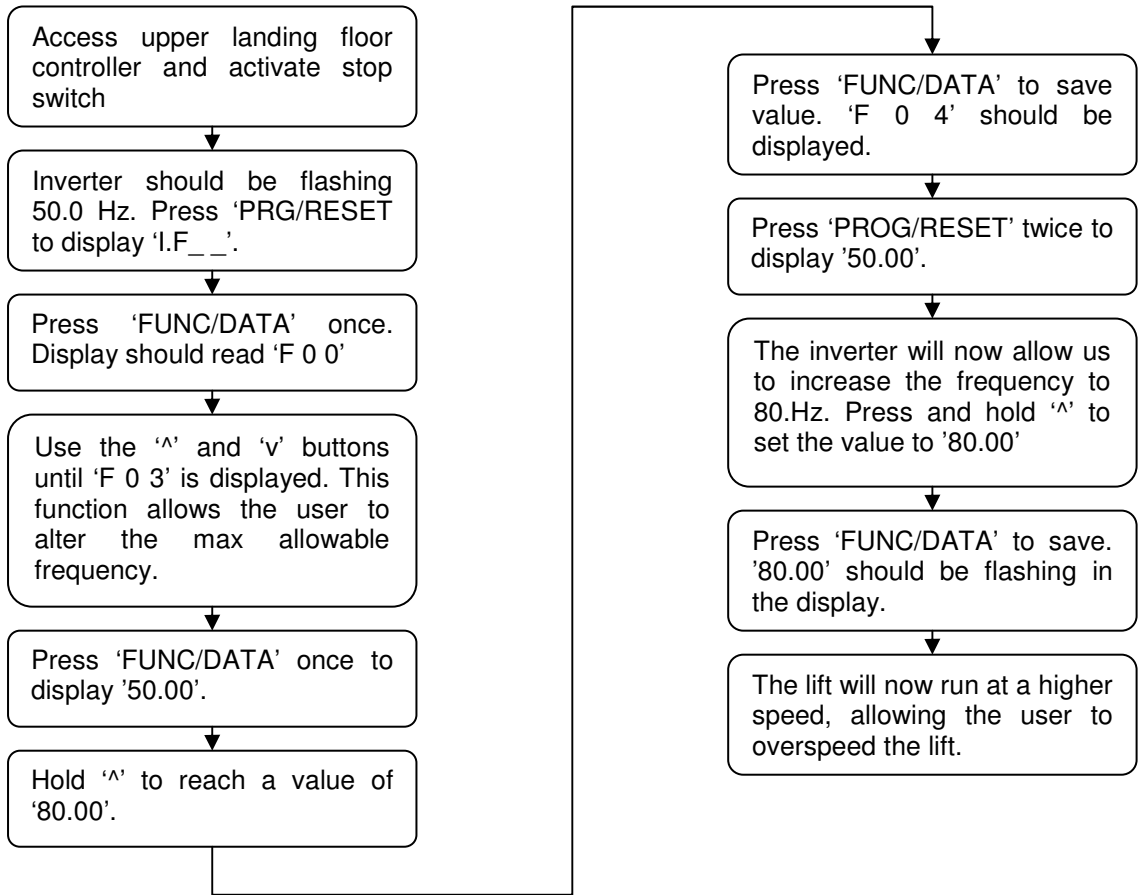

17.6 Re set the lift to run at 50.0 Hz

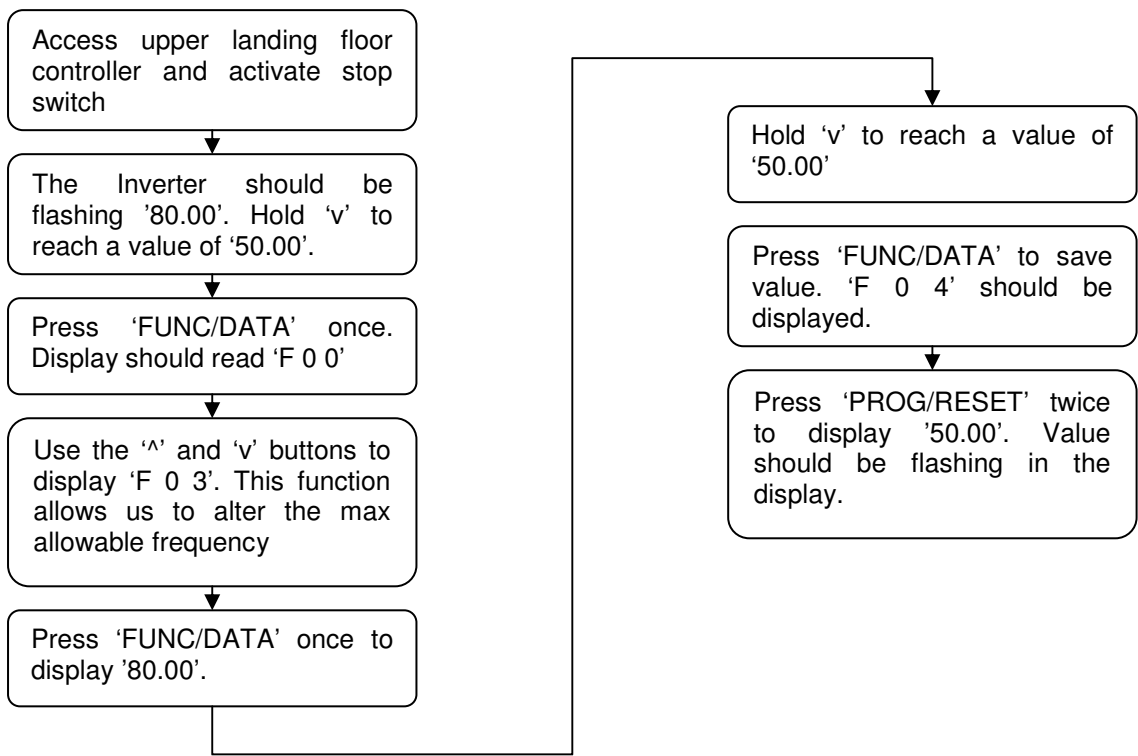

17.7 Overload controller calibrations

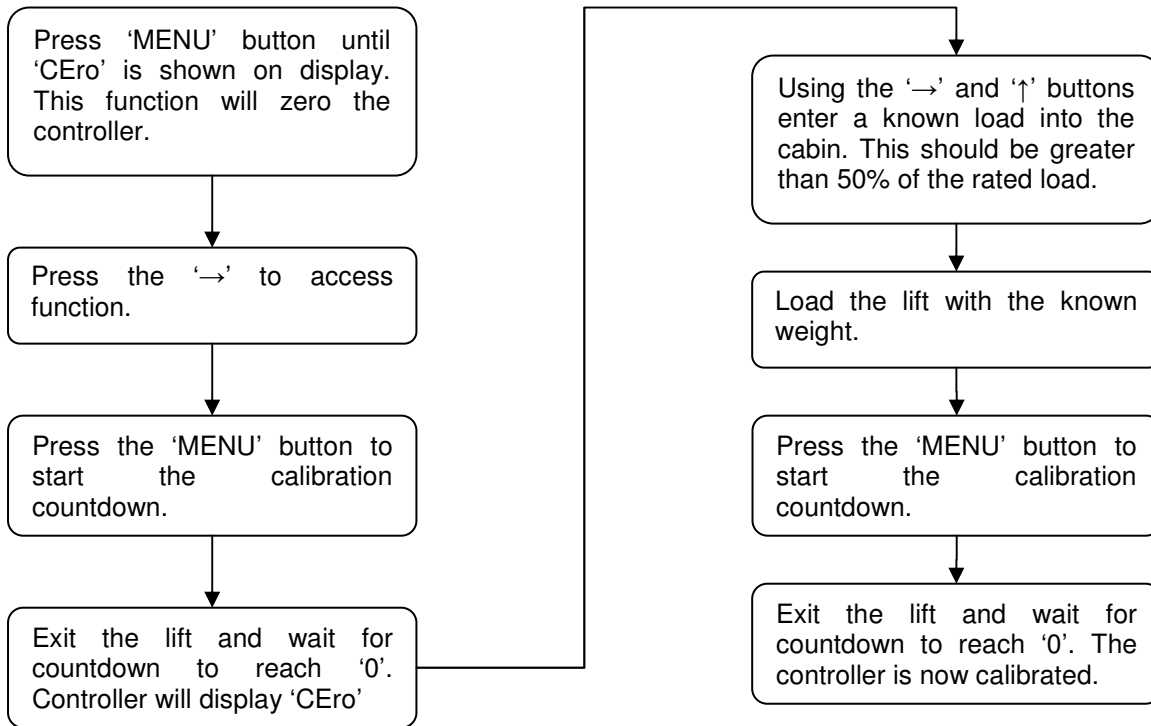

17.8 Overload alarm setup

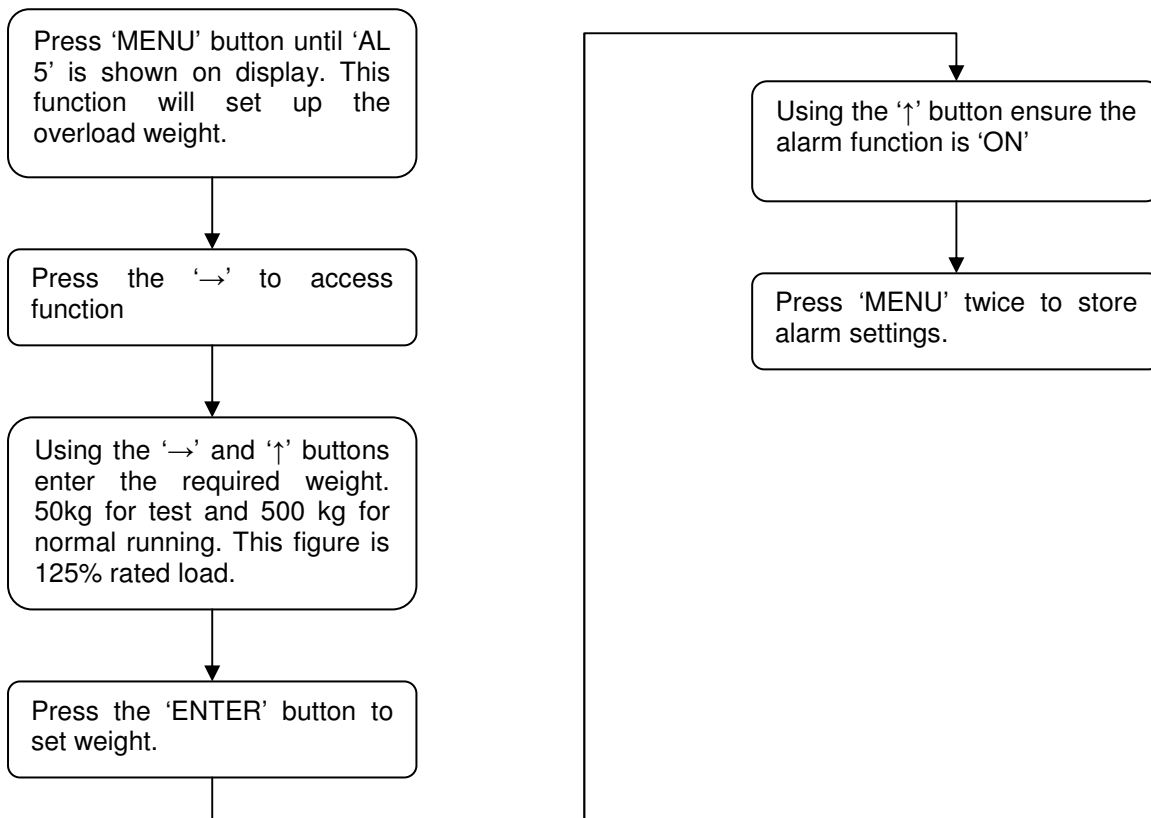

17.9 Safety chain switch locations

G1	Shutdown keyswitch	Main entrance landing station
G1A	Overspeed governor switch	Mounted on the overspeed governor
G1B	Overspeed governor rope switch	Mounted on the tension pulley assembly (pit)
G1C	Pit stop switch	Mounted on the base plate assembly (pit)
G1D	Test controls stop switch	Located in the upper landing control box
G1E	Landing controller stop switch	Located in the upper landing control box
G2	Hand-winding manual release switch	Located in the upper landing control box
G2A	Safety gear monitor switch	Mounted on the inside of each sling upright
G3	Ultimate limit switch	Mounted on the outside of one sling upright
G4	Carriage stop switch	Mounted on the COP within the cabin
G5	Landing door beak contacts	Between the door and frame at each landing
G6	Solenoid lock switches	Mounted on each solenoid lock (at each landing)
G7	Solenoid feed monitor	G7 terminal can be found on carriage control PCB
G7A	Invertor alarm / fault	Located in the upper landing control box
G7B	Cabin floor safety edge	Mounted on the entrance side of the floor assembly
G7C	Cabin roof safety edge	Mounted on the entrance side of the roof assembly
G8	Ceiling safety switch	Mounted on theslam side of the ceiling assembly

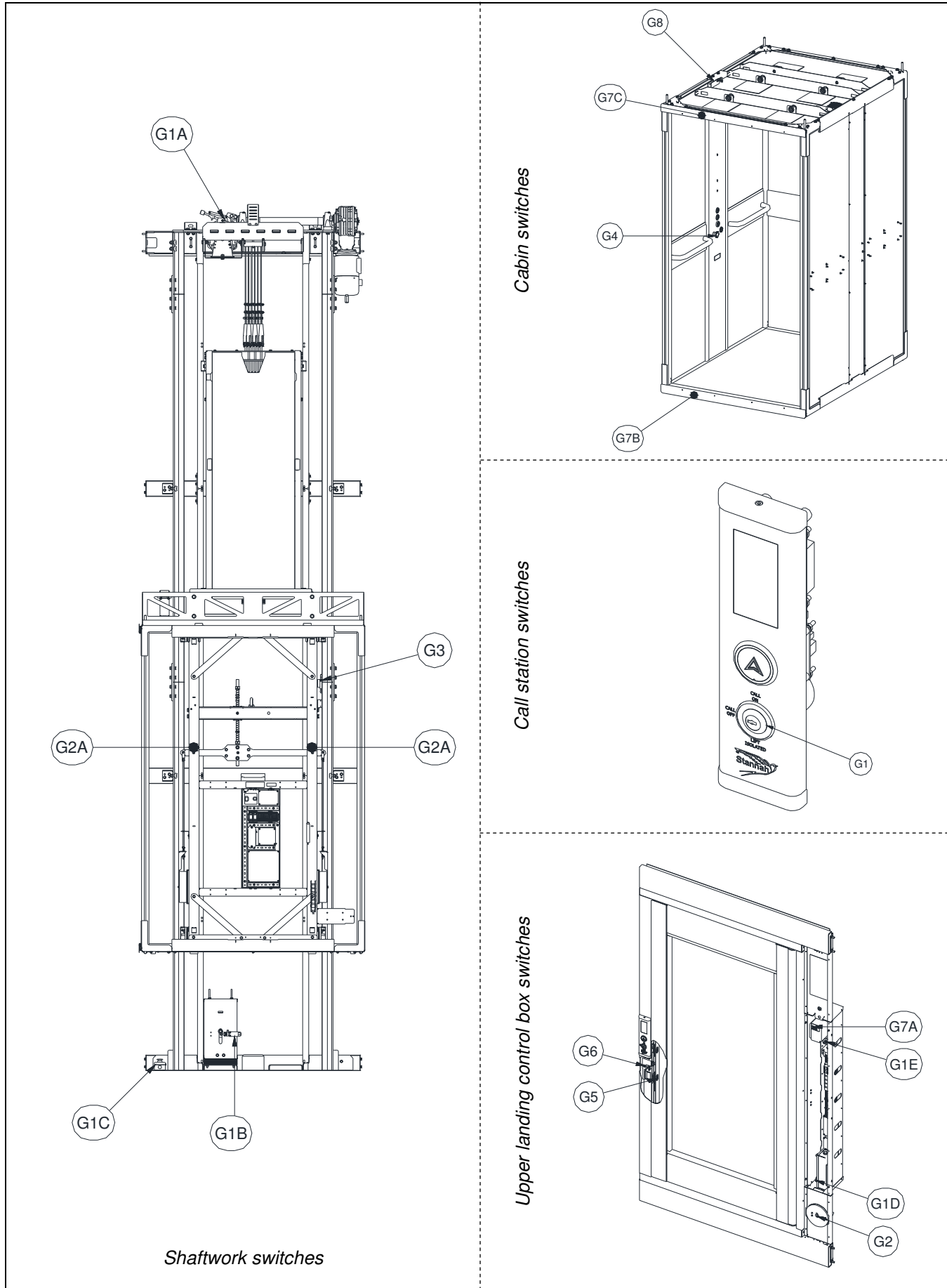

18 DOCUMENT HISTORY

Issue	Name	Changes	Date
Issue 6	R Christopher	Update to mechanical safety edge required standards and actions. Document history section added.	12 Feb 2021