

# Loads & Fixings (6m to 12m Travel)

Position	X (KN)	Y (KN)	Z (KN)	Comments
A	0	+/-0.7	0	Door threshold fixing at each entrance
B	+2.3	+/-0.6	0	Guide side top fixing
C1	+/-3.0	0	0	Guide side landing fixing
C2	+/-3.3	+/-0.8	0	Guide side intermediate landing fixing
D1	-3.1	+/-0.8	+7.2	Floor loads, guide side
D2	0	0	+7.2	Floor loads, opposite guide side
E	0	0	+10.0	Vertical load at the base of each car guide
F	0	0	+7.2	Vertical load at the base of each counterweight guide
G	0	0	+17	Vertical load at each car buffer
H	0	0	+26	Vertical load at the counterweight buffer

**Notes:**

- Details provided apply to indoor applications, travel between 6m & 12m, where all specified fixings can be made directly into solid substrate or structural members. The table & sketches show all loads from the lift.
- Loads**  
Loads from the lift occur in all 3 axes (X, Y & Z). All values stated in the table are per position indicated in the sketches. All loads stated are for 'worst case' conditions (of load & travel). Where applicable, an impact factor of 2 has been accounted for. Loads G & H are not concurrent. Loads stated are those in fixings at applicable positions.
- 2a. Horizontal plane fixings**  
Fixings at lettered positions (A, B, C1 & where applicable, C2) are compulsory. Forces apply in directions indicated in the table. Positive directions shown in the sketch 'Positive axes'. Fixings C2 are only required when the distance between floors is greater than 3.0m. Pitch between C fixings to be maximum 3.0m, minimum 1.5m.
- 2b. Vertical plane fixings**  
Fixings at D1 & D2 are compulsory. Fixings at D1 & D2 are made (vertically) into floor & are subject to loads in the X, Y & Z axes, as shown in the table. Loads in the Z axis at D1 & D2 are point loads due to structure weight.
- The lift well must not be situated above a space accessible to persons.
- It shall be the customer's responsibility to ensure suitability of the building structure for the applied loads, both in terms of strength, & also suitability of the fixings proposed. If any doubts exist, it is advised that a structural engineer is consulted.
- All dimensions in mm unless otherwise stated.
- This information sheet specifies loads for lift travels between 6m & 12m; for lower travels see separate datasheet.
- Provisions for securing the lift must be flush with the lift aperture and of sufficient thickness/depth to accommodate the appropriate fixing. Exact positions and types of fixings will be detailed on a site specific builders work drawing.

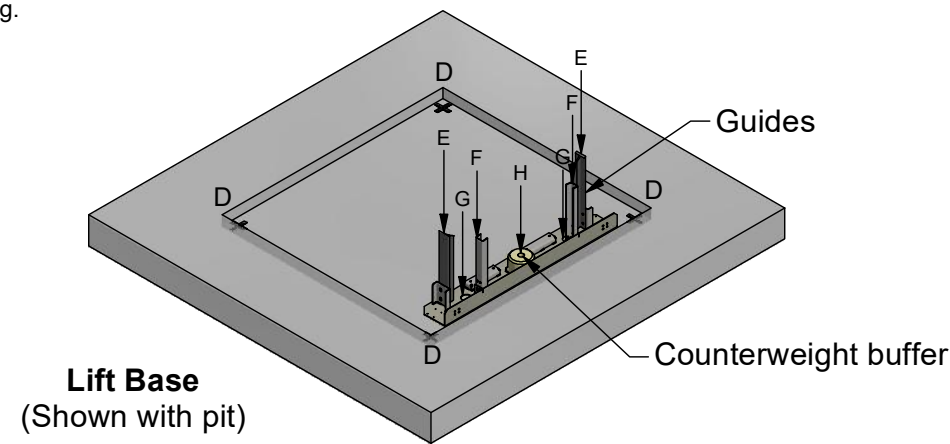
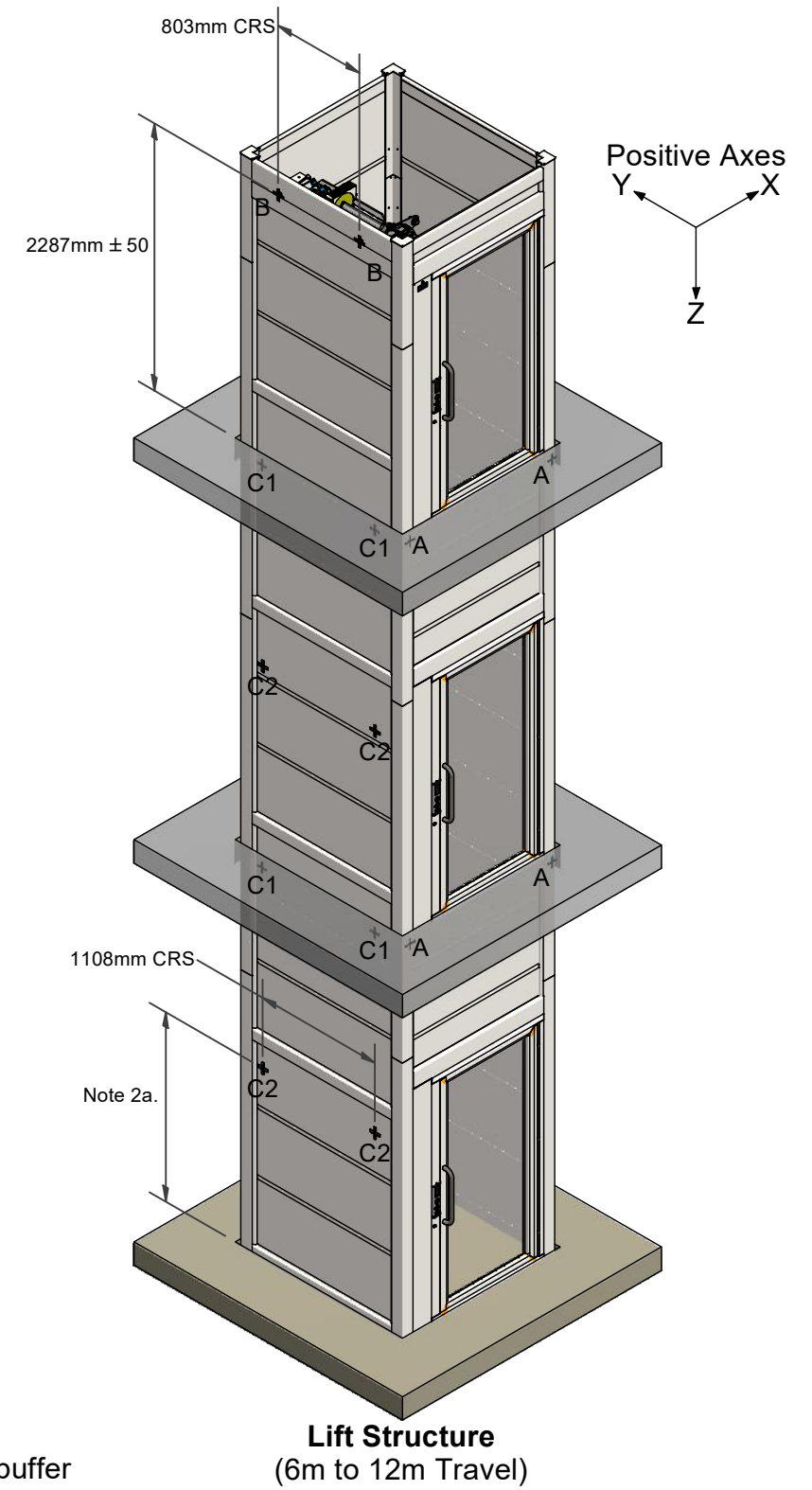

FIXING TYPES USED		
FIXING POSITION	MATERIAL	COMMENTS
A, B, C	Concrete	M12 studding ste into hilti HY70 resin with minimum embedment of 90mm.
A, B, C	Timber	10mm coach screws into timber beam with minimum depth 70mm.
A, B, C	Steel	M12 studding drilled and tapped into a steel plate of thickness 8mm.
D	Concrete	10mm expandable anchor with minimum depth 120mm.

**Waiver**

The data sheet is for guidance only & must not be used for proper working drawings. Please contact us for particular details before proceeding. Owing to our policy of continual improvement, we reserve the right to alter specifications & dimensions without prior notice.