

MIDILIFT USER HANDBOOK

IMPORTANT

Before using your Stannah Midilift platform lift, please ensure that you read and familiarise yourself with these instructions.

Stannah

CONTENTS

Introduction	3
Safety Instructions	6
Midilift GL/SL Platform Lift	8
Midilift SLplus Cabin Lift	14
Midilift XLplus Cabin Lift	20
Lift Features	26
Lift Care	28
Troubleshooting	29
Warranty Promise	30

INTRODUCTION

Important — please read

Thank you and congratulations on purchasing a Stannah Midilift platform lift.

Before using your lift, you should read this User Handbook to provide an understanding of the correct and safe use of the lift.

Your platform lift has been designed and manufactured in the UK. It has been installed and UKCA marked in compliance with the Supply of Machinery (Safety) Regulations 2008 (2008 No. 1597) and complies to the relevant parts of Lift Standard BS81-41:2010.

It is important that you arrange for the lift to receive regular inspection and servicing by a competent person at intervals at least every six months, after the guarantee period. A Service Log Card supplied by the Service branch will be completed after each service visit. Failure to ensure servicing is carried out could lead to unreliable or unsafe operation.

For all enquiries regarding servicing, please contact your local Stannah Service Branch.

For your records:



INTRODUCTION

LIFT SAFETY—YOUR RESPONSIBILITIES

Am I legally obliged to have my lift maintained?

Yes. The general duties imposed by The Health and Safety at Work etc Act 1974 supported by Provision and Use of Work Equipment Regulations 1998 (PUWER) regulations 5 & 10 mean that you are obliged to keep your lift in safe working order. This means you must arrange for regular maintenance of your lift.

Am I legally obliged to have my lift Thoroughly Examined?

Yes. Regulation 9 of the Lifting Operations and Lifting Equipment Regulations 1998 (LOLER) requires that a lift undergoes an inspection/thorough examination by a competent person at regular intervals (twice a year for passenger lifts, once for goods lifts or according to the lifts' situation) and applies to all lifts and lifting equipment used at work.

I have a lift in my building. What do I need to do?

You should arrange for the lift to be maintained (regularly serviced and kept in good repair) and, if the lift is in a place of work, thoroughly examined at intervals in line with legislation.

What is the difference between 'Maintenance' and 'Thorough Examination'?

Maintenance is the regular servicing of the lift, encompassing the routine adjustment to components, replacement of worn or damaged parts, topping up of fluids and so on, and should be carried out by an experienced and competent lift company, such as Stannah Lift Services. Maintenance is carried out to ensure the lift runs efficiently and safely.

Thorough Examination is the systematic and detailed visual inspection of the lift and all its associated equipment and would usually be carried out by a third party, or an appointed 'competent person'. Thorough Examination provides a good check that maintenance is being carried out properly. It focuses entirely on the safety of the equipment.

Authoritative guidance on Thorough Examination as required by Lifting Operations and Lifting Equipment Regulations 1998 (LOLER) can be found in The Guidelines for Supplementary Testing of In-Service Lifts published by SAFed. Thorough Examination may also be referred to as Form 54 or F54 inspection – the code given to the form prescribed by repealed Factories Acts. Although no longer prescribed, the term remains in use. Other common terms used are: periodic inspection, statutory inspection (because it is required by law) or insurance inspection (inspections were often on behalf of insurance companies).

Do I have a responsibility for trapped passengers?

Advice on this can be sought from your local Stannah Service Branch.

INTRODUCTION

PRODUCT LIFE EXPECTANCY

Product life expectancy depends largely on the environment, usage and the undertaking of proper scheduled maintenance. Our platform lift products are designed and life tested for a full life cycle of 10 years without major intervention. In most cases, we would expect our lifts to last far beyond this, providing they are properly cared for and maintained.

We have a number of platform lifts on our service portfolio that were installed from the late 1990s. The earliest of platform lifts installed are approaching 20 years in service.

Actual life expectancy of a lift depends on a number of factors, including:

- The load the lift actually carries on each journey
- The actual lift travel, as this determines the journey time and hence wear on the drive system
- The number of floors served by the lift
- The level of usage of the lift and whether this changes over time
- The environmental conditions that it operates within*
- The quality of the servicing and maintenance

We ensure that spare components are available for at least 10 years following the installation of any lift but many will be available far beyond this. There are a number of component parts that may require replacement during its life cycle and you will be advised of this as part of your lift servicing schedule.

*On the external option there is a five year anti-corrosion warranty (please see the warranty section).

SAFETY INSTRUCTIONS

- The lift must not be overloaded. The maximum rated load is displayed in the cabin, on the operating panel.
- The Midilift is a vertical platform lift intended primarily for the transportation of people with impaired mobility, including wheelchair users, the elderly, parents with pushchairs etc. The Midilift is designed to carry the majority of Type A and B wheelchairs, but not Type C wheelchairs or electric scooters due to their weight and size.
- A Midilift may also be used for the occasional transportation of light goods e.g.: stationery, luggage etc. subject to the lift/building owner carrying out a risk assessment.
- Like all vertical platform lifts, the Midilift is not designed to move large numbers of people quickly and frequently. The maximum recommended usage, or duty rating, for the Midilift is:

Midilift SL & SLplus	Hydraulic Models	0.08m/s maximum 20 journeys per hour
Midilift SL & SLplus	Hydraulic Models	0.15m/s maximum 30 journeys per hour
Midilift XLplus	Traction Drive	0.15m/s maximum 40 journeys per hour

- The emission sound pressure level for lift users is not expected to exceed 70dB(A).
- Children should not be allowed to tamper or play with the lift.
- The lift shall not be used for fire fighting or evacuation during fire.
- Check that doors are free from obstruction when opening.
- No goods or materials to be placed on or near the lift power pack unit. Access to this unit is required for lift service/maintenance and in the event of an emergency.
- A 'Lock Release' key will have been left by our installers, it is for use by trained lift engineers only - **do not attempt to use it yourself.**

Whenever a landing door is unlocked with the carrier not stationary or not at the level of the landing then persons on the landing will be at risk. It is therefore essential that any emergency door keys supplied are kept securely and only provided to a fully trained and authorised person (for example a trained lift engineer), who have the knowledge to use the key safely to open the door and to check the door has satisfactorily locked after it has been closed.

- Daily checks should be carried out by a person who is competent to do so to ensure that:
 - landing doors cannot be opened when the platform is not at the same level and;
 - the platform cannot travel without the doors closed and locked.

SAFETY INSTRUCTIONS

- If the lift is to be unused for an extended period of time it should be switched off when positioned at the lower level, via the isolation keyswitch. Ensure that all doors are securely locked.
- You should not attempt to dismantle or remove any parts of the platform lift. Such work should be entrusted only to competent personnel with the relevant expert knowledge and training.

MIDLIFT GL/SL PLATFORM LIFT

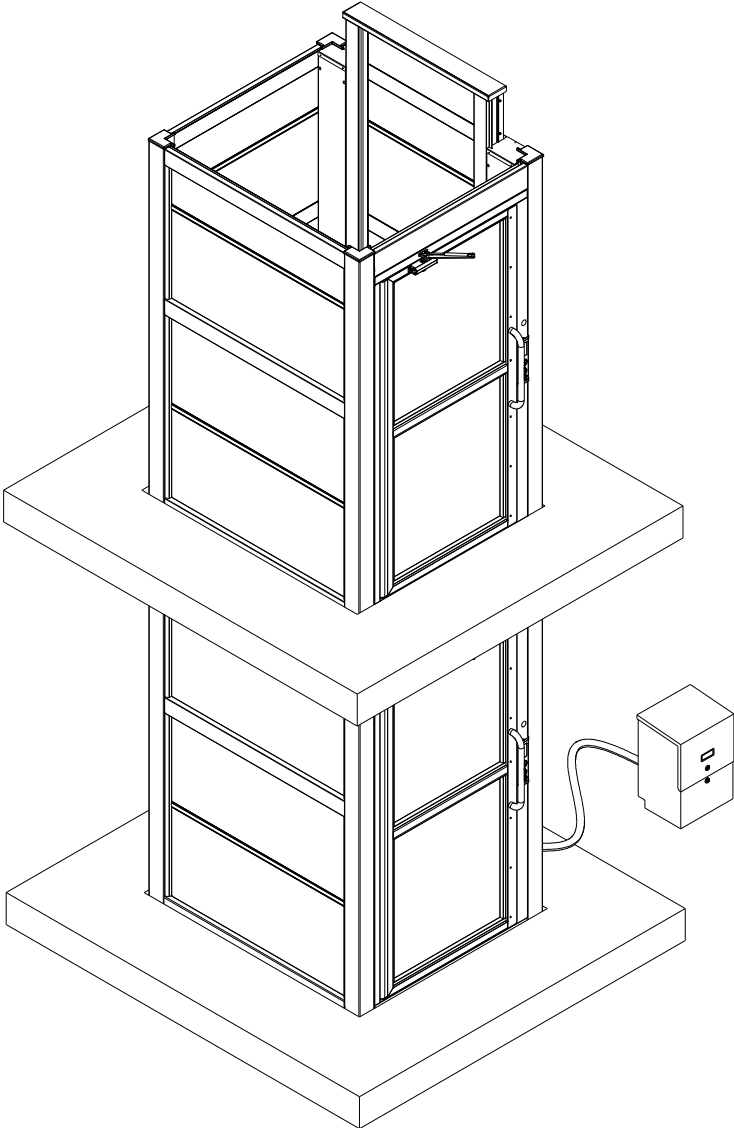

MIDILIFT GL/SL PLATFORM LIFT

A Midilift vertical platform lift is intended primarily for the transportation of people with impaired mobility, including wheelchair users, the elderly, parents with pushchairs etc. The Midilift is designed to carry the majority of Type A and B wheelchairs, but not Type C wheelchairs or electric scooters due to their weight and size.

The Midilift SL has a full height door on all levels (model shown to the left). The Midilift GL has a half height gate at the top landing but has no other operational differences.

LIFT OPERATION FROM THE LANDING

- On any entrance to the lift you will find a landing control faceplate (below).
- Digital display and keyswitch are optional parts but every landing will have a button for calling the lift and unlocking the door.
- As the button is pressed, the light around it will illuminate acknowledging its activation.
- If the lift is at the same level, the door will unlock allowing the user to manually open the door and enter the lift.
- If the lift is at a different level, the button will remain illuminated and the lift called to the landing that the button is pressed. When the platform arrives, the door will unlock allowing the user to manually open the door and enter the lift.

KEYSWITCH OPERATION

- At the lowest level, the keyswitch can be used to isolate the lift. By turning the keyswitch to the 'X' position the whole lift can be isolated to stop it being used.*
- Turn the keyswitch to '1' to enable the lift again and allow five seconds for the lift to reset.
- If the keyswitch has an '0' position then this can be used to only isolate the button at that landing. This option means that the lift can be only be accessed by those with the key.

'X'	- Isolate lift
'0'	- Isolate button only
'1'	- Lift operational



* This is the preferred method for turning the lift off. In this state the batteries on the lift will continue to be charged and lift use disabled. This is not the case if the lift is isolated at the main power source. Loss of power will mean that the lift will continue to operate in battery back up mode.

MIDLIFT GL/SL PLATFORM LIFT

LIFT OPERATION FROM THE PLATFORM

Operating Console



Stop Button

Digital display

Operating buttons

Alarm button

Intercom microphone

- When the lift door is closed and locked, the lift is ready to move.
- Operate the button of the level that you wish to travel to. Lift movement will be announced via the voice unit and an arrow displayed on the console.
- During lift travel, be aware of moving parts around you and ensure that any loose items and passengers are away from the sides of the moving platform.
- Upon reaching the floor, the door will unlock for 5 seconds giving opportunity to exit the lift.
- If the door should lock again simply press the floor button relating to the floor you are at and it will unlock again.
- Operation of the stop button will stop all lift movement. To release the stop, twist it clockwise until it has released.



In the event of experiencing difficulty in the lift, help can be alerted by continuously pressing the yellow alarm button. This action will ring the intercom handset elsewhere in the building, when answered, 2 way communication is possible and the button can be released. **

*** Intercom is the standard communication supplied with the lift. In some situations an automatic dialling system may be in place. If so, instructions are provided on the console and over the speaker. The system will dial predetermined phone numbers to put you in contact with a rescue service.*

MIDILIFT GL/SL PLATFORM LIFT

SAFETY EDGES

The platform lift has two safety edges fitted to protect the user from moving parts of the lift.

- Safety edge fitted around the platform floor. If depressed while travel in the up direction, the lift will stop and only continue when the obstruction is cleared.
- Safety edge fitted above the operating panel. If depressed while travel in the up direction, the lift will stop and only continue when the obstruction is cleared.
- Neither edges operate when the lift is travelling in the down direction.

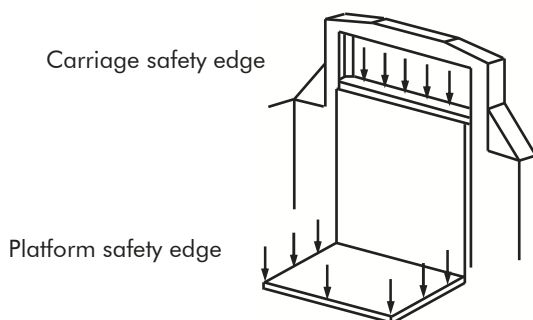

IN THE EVENT OF POWER LOSS TO THE LIFT

During power loss, the lift will revert to a battery back up supply fitted on the lift. This battery will maintain the power to the platform lighting, buttons, digital display and door locking. If fully charged it will do this for 1 hour. During power loss, the lift can only travel in the down direction.

In the event of power failure, during use:

- Push the lowest floor button and continuously hold it until the lift stops at the lowest landing.
- The door will unlock and the user can exit the lift.
- Turn the landing keyswitch to the 'Lift Off' position until power is reinstated.

MIDLIFT GL/SL PLATFORM LIFT

EMERGENCY RELEASING PASSENGERS

FOR USE BY TRAINED AND AUTHORISED PERSONNEL ONLY

! Opening of doors introduces risks. Emergency unlocking should be undertaken only in exceptional circumstances and by suitably trained and authorised persons. To be used only in an emergency by trained and authorised persons who have had instructions. It can be dangerous for any other person to attempt this procedure.

A manually operated hydraulic valve (located on the power pack) permits the platform, even in the case of **total** power failure, to be lowered in an emergency to the lower level where the passengers can be evacuated.

Lift Lowering Procedure

1. Switch OFF the lift mains electrical supply.
2. Ensure the lift doors are closed and locked.
3. Using the key provided, unlock and remove the lid on the power pack enclosure to enable access.
4. Locate the **RED** manual lowering knob on the manifold block. This knob can be pulled, pushed or turned to operate depending on the unit supplied.
5. Inform the trapped passengers within the lift that you are about to lower the platform and request they remain clear of the platform edges.
6. Operate the red manual lowering knob to lower the platform. The platform will stop when the knob is released. Release the knob when the lift platform is touching the lower level floor.
7. Replace and lock the power pack enclosure lid.
8. With the lift at floor level, remove the door lock cover.
9. Using the door lock release key, insert the key and turn 90° until the latch releases the door lock.
10. Whilst holding the lock open with the key, manually open the platform lift door to release the passengers.
11. Once the lift is vacated, leave the platform lift mains electrical supply switched off, close and lock the platform lift door and telephone your local service branch.
12. Ensure and prove that the doors are closed and locked.

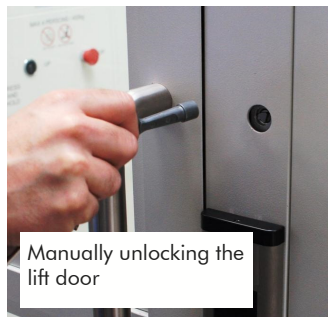

This page has been intentionally left blank.

MIDLIFT SLPLUS CABIN LIFT

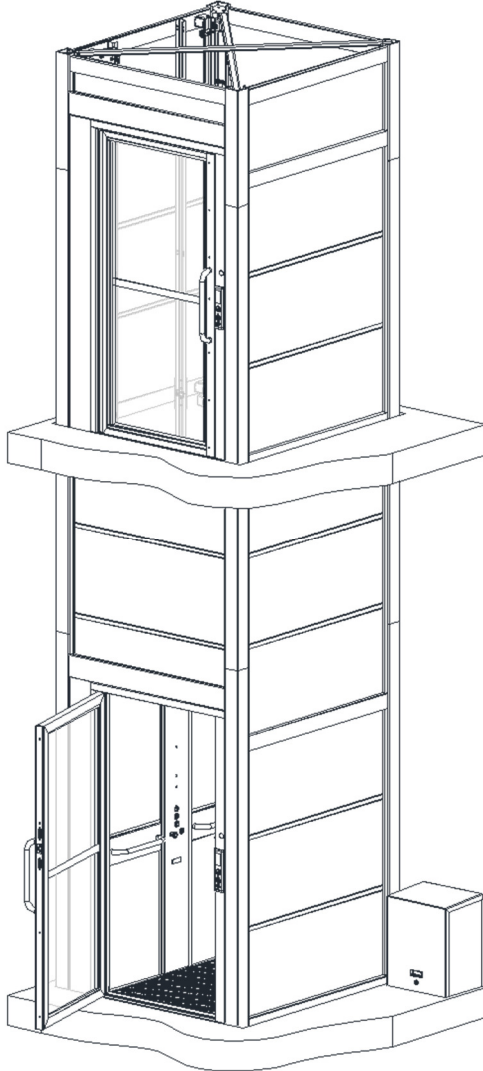

MIDLIFT SLPLUS CABIN LIFT

The Midilift SLplus is a hydraulic cabin platform lift for the moving of persons between a number of levels. Its operation differs from a standard passenger lift in that it is limited in speed to 0.15m/s.

LIFT OPERATION FROM THE LANDING

- As you approach any entrance to the lift you will find a landing control faceplate.
- These faceplates may differ slightly from this picture. Digital display and keyswitch are optional parts but every landing will have a button for calling the lift or unlocking the door.
- As the button is pressed, the light around it will illuminate acknowledging its activation.
- If the lift is at the same level, the door will unlock allowing the user to manually open the door and enter the lift.
- If the lift is at a different level, the button will remain illuminated and the lift called to the landing that the button is pressed. When the platform arrives, the door will unlock allowing the user to manually open the door and enter the lift.

KEYSWITCH OPERATION

- At the lowest level, the keyswitch can be used to isolate the lift. By turning the keyswitch to the 'Lift off' position the whole lift can be isolated to stop it being used.*
- Turn the keyswitch to 'On' to enable the lift again and allow five seconds for the lift to reset.
- If the keyswitch has an 'Off' position then this can be used to only isolate the button at that landing. This option means that the lift can be only be accessed by those with the key.

'Lift Off'	- Isolate lift
'Off'	- Isolate button only
'On'	- Lift operational

Digital Display Unit

Call Button

Keyswitch



** This is the preferred method for turning the lift off. In this state the batteries on the lift will continue to be charged and lift use disabled. This is not the case if the lift is isolated at the main power source. Loss of power will mean that the lift will continue to operate in battery back up mode.*

MIDLIFT SLPLUS CABIN LIFT

LIFT OPERATION FROM THE CABIN

- When the lift door is closed and locked, the lift is ready to move.
- Standing in front of the console, press the button for the level that you wish to travel to. The button will illuminate. Lift movement will be announced via the voice unit and an arrow displayed on the console.
- During lift travel, be aware of moving parts around you and ensure that any loose items and passengers are away from the sides of the moving platform.
- Upon reaching the destination floor, the door will unlock for five seconds giving opportunity to exit the lift.
- If the door should lock again simply press the floor button relating to the floor you are at and it will unlock again.
- Operation of the stop button will stop all lift movement. To release the stop, twist it clockwise until it has released.



In the event of experiencing difficulty in the lift, help can be alerted by continuously pressing the yellow alarm button. This action will ring the intercom handset elsewhere in the building, when answered, two-way communication is possible and the button can be released. **

*** Intercom is the standard communication supplied with the lift. In some situations an automatic dialling system may be in place. If so, instructions are provided on the console and over the speaker. The system will dial predetermined phone numbers to put you in contact with a rescue service.*

MIDILIFT SLPLUS CABIN LIFT

SAFETY EDGES

The cabin lift has safety edges fitted to protect the user from moving parts of the lift. The protection is provided by 2 different methods:

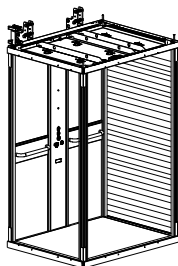

Light curtain protection

This is provided by sensors fitted on the vertical plane of the lift entrances. If interrupted during travel, the lift will stop moving until the obstruction is cleared. This is also indicated by the lift voice advising the user to move away from the obstruction.

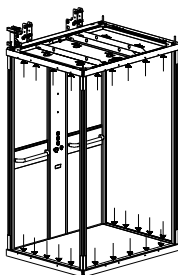

Mechanical safety edge

This is provided by a metal strip at the bottom and top of the lift entrance. If depressed during lift travel the lift will stop moving until the obstruction is cleared.

IN THE EVENT OF POWER LOSS TO THE LIFT

During power loss the lift will revert to a battery back up supply fitted on the lift. This battery will maintain the power to the emergency lighting, buttons, Digital display and door locking. If fully charged it will do this for one hour.

During power loss the lift can only travel in the down direction.

In the event of power failure during use:

- Place a call to the lowest landing.
- The door will unlock and the user can exit the lift.
- Turn the landing keyswitch to the 'Lift Off' position until power is reinstated.

MIDLIFT SLPLUS CABIN LIFT

EMERGENCY RELEASING PASSENGERS

FOR USE BY TRAINED AND AUTHORISED PERSONNEL ONLY



Opening of doors introduces risks. Emergency unlocking should be undertaken only in exceptional circumstances and by suitably trained and authorised persons. To be used only in an emergency by trained and authorised persons who have had instructions. It is dangerous for any other person to attempt this procedure.

MANUAL LOWERING OF THE CABIN

There are two manually operated valves (located on the power pack) that permit the cabin to be lowered to the lowest entrance even during total power failure. Following this any trapped passengers can be released.

Lift Lowering Procedure

1. Switch OFF the lift mains electrical supply.
2. Ensure the lift doors are closed and locked.
3. Using the key provided, unlock and remove the lid on the power pack enclosure to enable access.
4. Locate the **2 RED** manual lowering knobs within the enclosure. These knobs can be pulled, pushed or turned to operate depending on the unit supplied.
5. Inform the passengers in the lift that you are going to lower the cabin and request they stay clear of the sides. (Safety edges are inoperative during this operation)
6. Operate both red manual lowering knobs at the same time to lower the cabin. The cabin will stop if either knobs are released. Release the knobs when the cabin is touching the lower level floor.
7. Replace and lock the power pack enclosure lid.
8. With the lift at the lowest floor level, locate the manual release lock for the door.
9. Using the door lock release key, insert the key and turn 90° until the latch releases the door.
10. Whilst holding the lock open with the key, manually open the platform lift door to release the passengers.
11. Once the lift is vacated, leave the platform lift mains electrical supply switched off, close and lock the platform lift door and telephone your local service branch.
12. Ensure and prove that the doors are closed and locked.

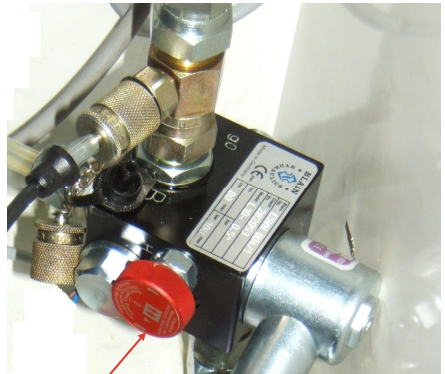

The RED manual lowering knobs will be positioned closely together and will both look like the picture shown above.



Manually unlocking the lift door

This page has been intentionally left blank.

MIDLIFT XLPLUS CABIN LIFT

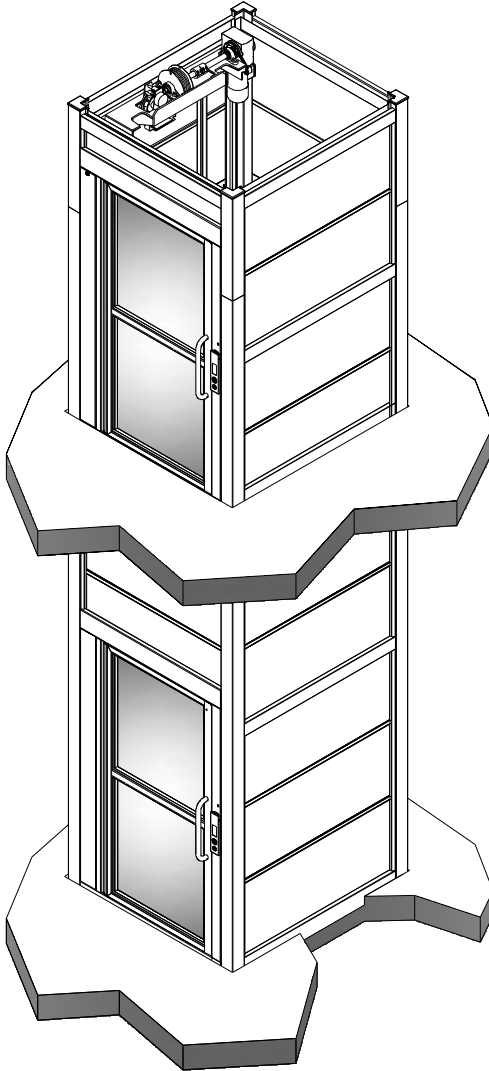

MIDILIFT XLPLUS CABIN LIFT

The Midilift XLplus is a traction cabin platform lift driven from a motor at the top landing. Its operation differs from a standard passenger lift in that it is limited in speed to 0.15m/s.

LIFT OPERATION FROM THE LANDING

- As you approach any entrance to the lift you will find a landing control faceplate.
- These faceplates may differ slightly from the picture below. Digital display and keyswitch are optional parts but every landing will have a button for calling the lift or unlocking the door.
- As the button is pressed, the light around it will illuminate acknowledging its activation.
- If the lift is at the same level, the door will unlock allowing the user to manually open the door and enter the lift.
- If the lift is at a different level, the button will remain illuminated and the lift called to the landing that the button is pressed. When the platform arrives, the door will unlock allowing the user to manually open the door and enter the lift.

KEYSWITCH OPERATION

- At the lowest level, the keyswitch can be used to isolate the lift. By turning the keyswitch to the 'Lift off' position the whole lift can be isolated to stop it being used. *
- Turn the keyswitch to 'ON' to enable the lift again and allow 5 seconds for the lift to reset.
- If the keyswitch has an 'Off' position then this can be used to only isolate the button at that landing. This option means that the lift can be only be accessed by those with the key.

'Lift Off'	- Isolate lift
'Off'	- Isolate button only
'On'	- Lift operational

Digital Display Unit

Call Button

Keyswitch



* This is the preferred method for turning the lift off. In this state the batteries on the lift will continue to be charged and lift use disabled. This is not the case if the lift is isolated at the main power source. Loss of power will mean that the lift will continue to operate in battery back up mode.

MIDILIFT XLPLUS CABIN LIFT

LIFT OPERATION FROM THE CABIN

- When the lift door is closed and locked, the lift is ready to move.
- Standing in front of the console, press the button for the level that you wish to travel to. The button will illuminate. Lift movement will be announced via the voice unit and an arrow displayed on the console.
- During lift travel, be aware of moving parts around you and ensure that any loose items and passengers are away from the sides of the moving platform.
- Upon reaching the destination floor, the door will unlock for five seconds giving opportunity to exit the lift.
- If the door should lock again simply press the floor button relating to the floor you are at and it will unlock again.
- Operation of the stop button will stop all lift movement. To release the stop, twist it clockwise until it has released.



In the event of experiencing difficulty in the lift, help can be alerted by continuously pressing the yellow alarm button. This action will ring the intercom handset elsewhere in the building, when answered, 2 way communication is possible and the button can be released. **

** Intercom is the standard communication supplied with the lift. In some situations an automatic dialling system may be in place. If so, instructions are provided on the console and over the speaker. The system will dial predetermined phone numbers to put you in contact with a rescue service.

MIDILIFT XLPLUS CABIN LIFT

SAFETY EDGES

The cabin lift has safety edges fitted to protect the user from moving parts of the lift. The protection is provided by two different methods:

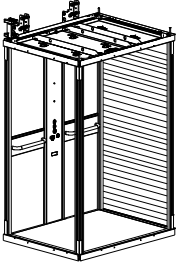

Light curtain protection

This is provided by sensors fitted on the vertical plane of the lift entrances. If interrupted during travel, the lift will stop moving until the obstruction is cleared. This is also indicated identified by the lift voice advising the user to move away from the obstruction.

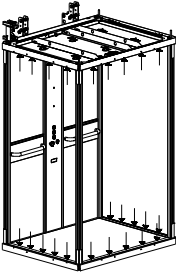

Mechanical safety edge

This is provided by a metal strip at the bottom and top of the lift entrance. If depressed during lift travel the lift will stop moving until the obstruction is cleared.

IN THE EVENT OF POWER LOSS TO THE LIFT

During power loss the lift will revert to a battery back up supply fitted on the lift. This battery will maintain the power to the emergency platform lighting, buttons, Digital display and door locking. If fully charged it will do this for one hour.

If the user is at landing the door can be unlocked by pressing the button of the floor that the lift cabin is located.

MIDILIFT XLPLUS CABIN LIFT

EMERGENCY RELEASING PASSENGERS

FOR USE BY TRAINED AND AUTHORISED PERSONNEL ONLY

! Opening of doors introduces risks. Emergency unlocking should be undertaken only in exceptional circumstances and by suitably trained and authorised persons. To be used only in an emergency by trained and authorised persons who have had instructions. It is dangerous for any other person to attempt this procedure.

Manual Lowering Procedure

1. Switch OFF the lift mains electrical supply.
2. Ensure the lift doors are closed and locked.

Note: The manual release can be accessed next to the upper floor landing door.

3. Access the control unit situated at the top landing adjacent to the lift door. Using the key provided, unlock the panel and remove it from the frame (image A). This will provide access to the shaft electrical components and manual lowering equipment.
4. At the top of the panel there is a square shaft protruding. When pressed in (image B), this engages with the motor shaft and allows the lift to be manually moved.
5. Press shaft inwards (image B) if the shaft does not move, rotate the shaft a small amount, then try again.
6. Slide the locking bracket down to lock the shaft in the 'engaged' position (image C).

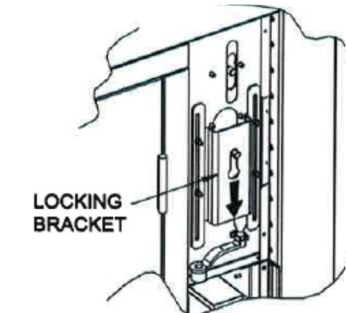
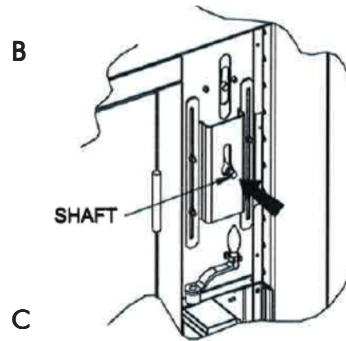
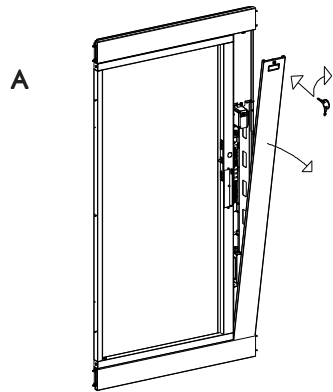

MIDILIFT XLPLUS CABIN LIFT

7. Place the handle onto the end of the shaft and, while holding the brake release lever down, rotate to move the lift in the desired direction. (image D) Lift movement is slow but controlled.
8. Once the cabin has been moved to the lowest landing, replace the handle back to its storage position and slide the locking bracket back up (image E).
9. Leave power switched off and manually release any passengers.

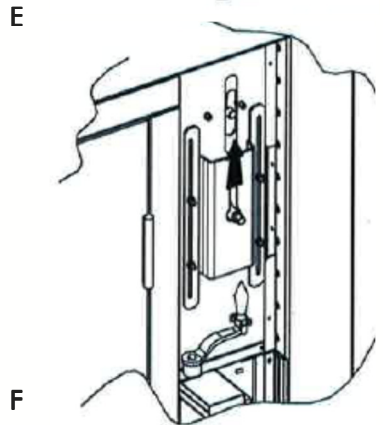
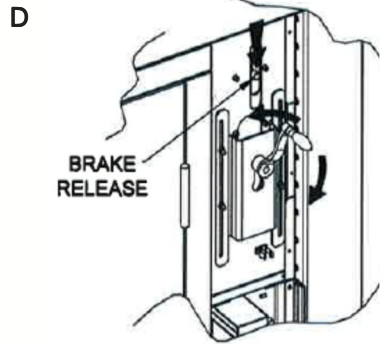

Passenger Release Procedure

1. Once the lift is at floor level remove the lock cover.
2. Using the door lock release key, insert the key and turn 90° until the latch releases the door (image F).
3. Whilst holding the lock open with the key, manually open the platform lift door to release the passengers.
4. Once the lift is vacated, leave the platform lift mains electrical supply switched off, close and lock the platform lift door and telephone your local service branch.
5. Ensure and prove that the doors are closed and locked.

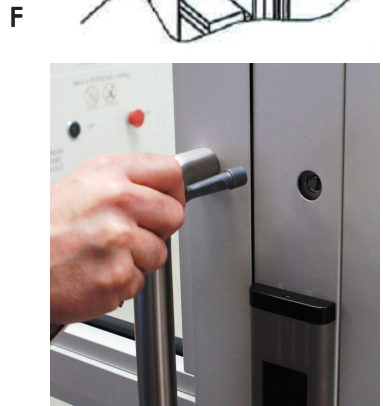

Important: Passengers should always be evacuated at the lowest level. It is potentially dangerous to release passengers at any other levels.

LIFT FEATURES

The following provides an overview of the features on your platform lift. To find your lift type please refer to the information on page three.

AUTOMATIC DOOR CLOSER/OPENER (OPTION)

As standard, the lift is supplied with manual door closers. Individual landings can be supplied with optional automatic door closer/openers; operated using the landing or cabin call buttons.

On the first operation, i.e. after lift power on, the automatic door will open and close very slowly. This function allows the system to learn its surroundings and calibrate its stopping positions. Following this automatic calibration the door will open and close at normal speed. If the door meets any obstruction during subsequent operations the door will stop, reclose and open at the slow speed.

Door open and unlocking times can be adjusted if required. Please speak to your service engineer if you require it to be changed.

COMMUNICATION DEVICES

INTERCOM - The intercom is supplied on the standard product and allows the user to connect with someone within the building in the event of an emergency. The alarm button on the lift console 'rings' the handset that is placed in a suitable location in the building. Once the handset receiver is picked up, a 2 way conversation can take place.

AUTODIALLER (OPTION) - When the alarm is pressed the autodialler will automatically phone out to the programmed emergency numbers. The autodialler is situated on the control panel. If requested, the autodialler can be installed with an induction loop for the hard of hearing. Phone number changes have to be performed by a lift engineer.

TELEPHONE (OPTION) - A dedicated phone line will be situated on the cabin control panel, enabling the user to phone out in an emergency.

Note: With all communication systems it remains the responsibility of the building owner to ensure effective measures are in place to deal with the possible outcome of users being trapped inside the lift. i.e. who could be using the lift? Could it be out of normal hours? Are the systems regularly tested? Etc...

LIFT FEATURES

DIGITAL DISPLAY OPERATION

The digital display on the console will visually indicate lift operation to the user, floor numbers and arrows. In the unlikely event of the lift obtaining a fault, the display may be used to present fault codes to aid fault finding for the engineer. If these are observed please make a note of them to communicate to the engineer upon arrival.

DUAL CONTROL (OPTION)

Where required, a second set of platform controls can be specified and fitted opposite the main operating console. The second set of controls are typically a duplicate of the car operating buttons, including the alarm button. The controls are on a 'first come, first serve' basis (i.e. neither set of controls has priority). The operation and function of the lift is otherwise unchanged.

FIRE ALARM SHUT DOWN

Some buildings have a lift interface for the fire alarm system. When activated, the lift will automatically travel to the ground floor should a fire alarm occur, all calls will be disabled and the car door open button will still operate allowing users to exit the lift.

FOLD DOWN SEAT (OPTION)

If selected as an option for your lift, the fold down seat provides seating for one person for the duration of the lift travel. When not in use it will fold away to occupy less space.

OVERLOAD CONDITION

The lift will have a maximum load rating identified on the console. Should this load be exceeded, the lift will stop operating, display a flashing 'OL' on the digital display and announce "lift overload". Should this occur, the additional load should be removed from the lift to return to normal service.

ROOF FAN (OPTION)

Where required, a fan can be fitted into the roof, drawing in fresh air to increase circulation in hot climates.

LIFT CARE

The following lift care procedures carried out regularly will help to keep your lift in good condition:

- Paint finishes and panels should be cleaned with a damp soft cloth and mild detergent. Ensure that excess water is squeezed out prior to cleaning.
- Vinyl skin plate and laminate boards should be cleaned with a soft cloth using a furniture polish aerosol.
- Stainless steel components should be cleaned with a soft cloth, using baby oil or a propriety stainless steel cleaner and then wiped off with a dry, lint-free cloth.
- Mirrors should be cleaned with a soft cloth and any glass cleaning fluid.
- Flooring should be cleaned with a damp cloth and mild detergent. Ensure that excess water is squeezed out prior to cleaning.
- Never leave objects resting against the doors, door frames or car finishes.
- For outdoor installations and coastal high saline environments, servicing frequency remains the same but more frequent monthly routine care must be introduced, this can be undertaken by the lift owner or service company and includes:
 - One full cycle of the lift operation.
 - Cleaning of paint work.
 - Removal of any debris or leaves.
 - Inspection and reporting of any vandalism or misuse which has resulted in damage to the protective surface.
 - Pressure washers should not to be used.

TROUBLESHOOTING

If your lift fails to operate check the following list before contacting your local service branch - it could save you time and the cost of an unnecessary service call:

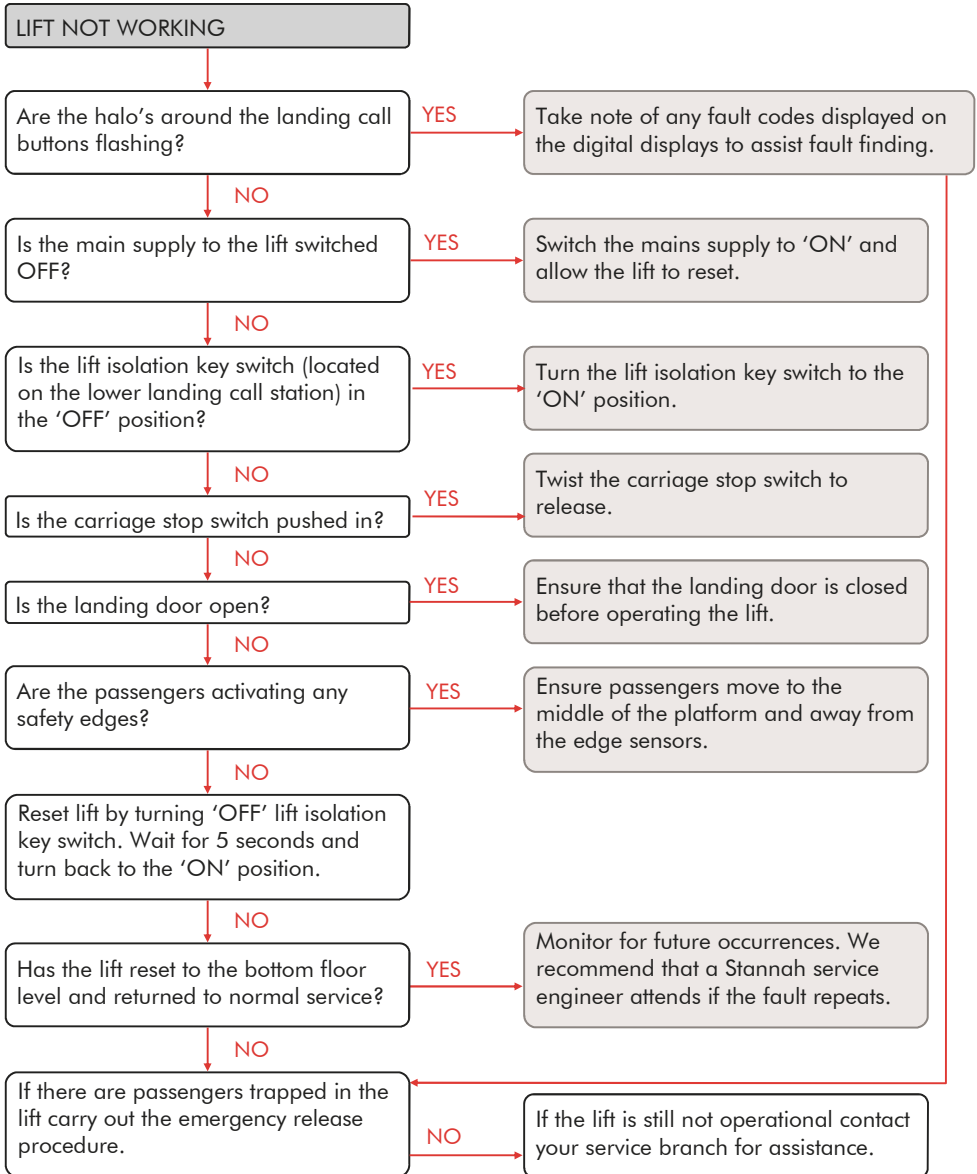

WARRANTY PROMISE

Our Guarantee

Stannah Lifts Ltd is pleased to guarantee our materials and workmanship, and provide a maintenance and breakdown service, supplied by our sister company Stannah Lift services, for a period of 12 months from completion of installation and handover of the lift*, as follows:

- We will provide regular planned maintenance visits at the frequency agreed in the contract, subject to suitable access to the lift within normal working hours.
- We will provide a full breakdown service within normal working hours, unless caused by misuse, abuse, accidental damage or other matters outside of our control, in which case it will be chargeable. Normal working hours are Monday to Thursday 8.00am to 4.45pm, Friday 8.00am to 3.45pm. Evening and weekend breakdowns will be charged at a premium rate, unless included within the contract.
- Should any defect in workmanship or material become evident within such period or in any part delivered under this contract, we undertake to repair or replace the defective part, as soon as possible during normal working hours.
- Our Guarantee does not cover repairs, replacements or adjustment which may be required as a result of ordinary wear and tear, wilful or accidental damage, misuse, neglect or any other cause beyond our control.
- Lifting platforms must be regularly serviced by a technically competent Lift Engineer. For the external option on our Midilift SL/GL, we require that at least four service visits are carried out at regular intervals annually in order to preserve the five year anti corrosion warranty. Claims cannot be accepted for corrosion that occurs as a result of misuse, neglect, unauthorised alterations or improperly repaired paintwork.
- The address and telephone number of your nearest Service Branch is on the 'Completion Notice' and a full list of all service branches can be found on our website www.stannahlifts.co.uk.

*Our external products are also covered by a five year anti corrosion warranty.

Continued on right.....

WARRANTY PROMISE

The Warranty Promise is subject to the following conditions:

- The lift has been formally handed over and the 'Completion Notice' is signed.
- All outstanding monies have been paid to us.
- No other lift company has worked on the lift, e.g. carrying out a maintenance visit, attending a breakdown or attempting a repair.
- Stannah is not prevented from carrying out planned maintenance for any reason outside of our control, including but not limited to, the safety of our employees engaged in activities under this warranty.
- The lift well and machine room or machine space must be freely accessible, free from damp, properly ventilated and maintained in line with any requirements detailed within the user manual.

Stannah reserve the right to change the terms of any warranty provided subject to any such change being notified to the beneficiary in writing.

NOTE

Whilst every effort has been used to ensure the clarity and accuracy of this Handbook, we cannot be held responsible for damage or injury resulting from negligence or misuse of this lift equipment.

We are continually developing and improving the Midilift range and we therefore reserve the right to alter or amend the specification without prior notice.



Stannah Lifts Ltd

Telephone: 01264 339090

Email: contact@stannah.co.uk

Midilift UM—Jun22

www.stannahlifts.co.uk

Stannah