

**Waiver:**

This data sheet is for guidance only & must not be used for proper working drawings. Please contact Stannah Lifts for particular details before proceeding. Owing to our policy of continual improvement, we reserve the right to alter specifications & dimensions without prior notice.

For Guidance only

# MIDILIFT DL

Wheelchair  
Vertical Lifting Platform 1100 x 1400  
Through, Adjacent and Same Side Entry/Exit



**Standard Supply**

- Compliances:** Machinery Directive 89/392 EEC, Building Regs. Part M where this lift type applicable.
- Traction:** Hydraulic with pump unit installed near to lift.
- Rated Load:** 350 kg
- Operation:** Constant pressure push button control
- Max. No. of stops:** 5
- Max. travel:** 7000mm (longer travels are available, please seek technical advice)
- Min. overhead:** 2700mm (less by special arrangement)
- Min. pit depth:** 100mm (or ramp by others)
- Cabin speed:** 0.15m/s (nominal)
- Cabin height:** 2100mm
- Power supply:** Dedicated 240 V single phase a.c., 13A rated
- Motor power:** 1.5 kW
- Entrances:** Through, adjacent or same side entry/exit.
- Landing doors:** Single panel swing door (self closing), grey primed (RAL 7038) for finish painting by others.
- Landing call stations:** Constant pressure call buttons, switch with removable key to activate the buttons ("keyswitch")
- Cabin:** Partially closed with pre-painted steel panel walls, grille ceiling panel with maintained lighting, anti-slip floor covering, safety light rays at entrances, handrail.
- Cabin push buttons:** Send push buttons, acoustic alarm, keyswitch & stop buttons. Emergency lowering & alarm functions are supported by internal battery if power fails.

**Options**  
(subject to application)

**Cabin:** Half or full height mirror, additional handrail, intercom, telephone handset, autodialler, solid ceiling infill panels, glass wall panels.

- Structure:** Glass or steel cladding panels, roof panel.
- Pump unit:** Oil heater (for low temperature applications)
- Landing door options:** Panoramic vision panel.  
Full height light ray  
Security lock  
1 hour fire rating.

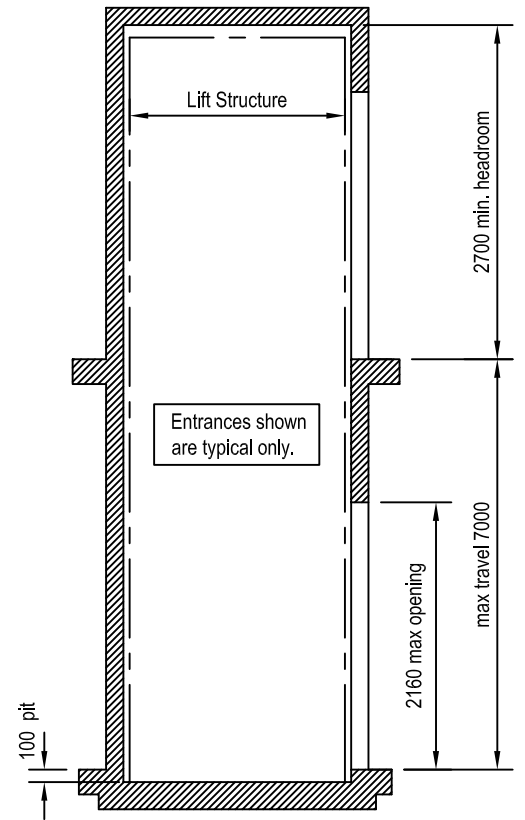
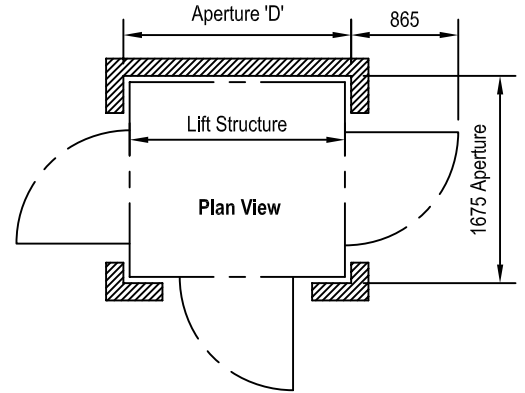

Door entrance position	Aperture 'D'
A or C	1790
A & C	1840
B	1740
A & C or B & C	1790

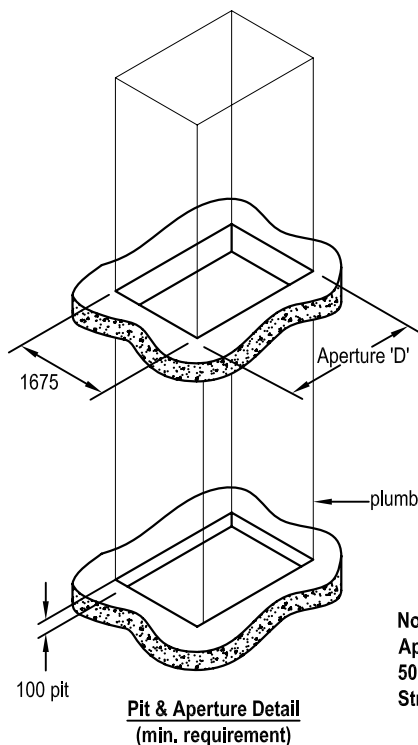

**Note:**  
Aperture & Pit sizes are 50mm larger than the Lift Structure on all sides.

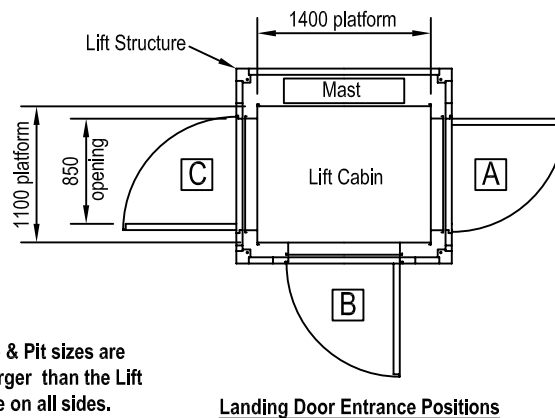

**For typical loadings see  
Information Sheet  
AVL750**

**INFORMATION SHEET  
AVL 720  
04.01.08**