

# Maxilift 2.0

## 6 Person (450kg)

### MRL Hydraulic

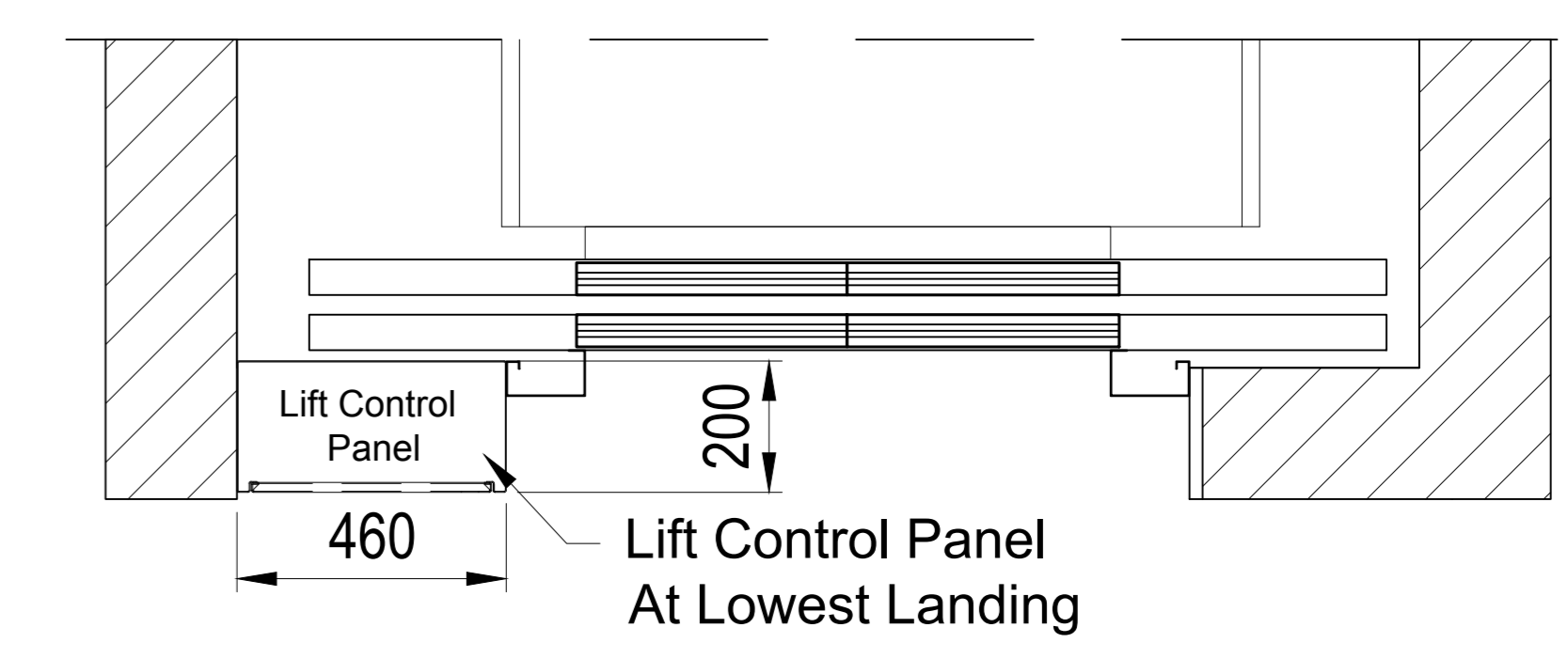
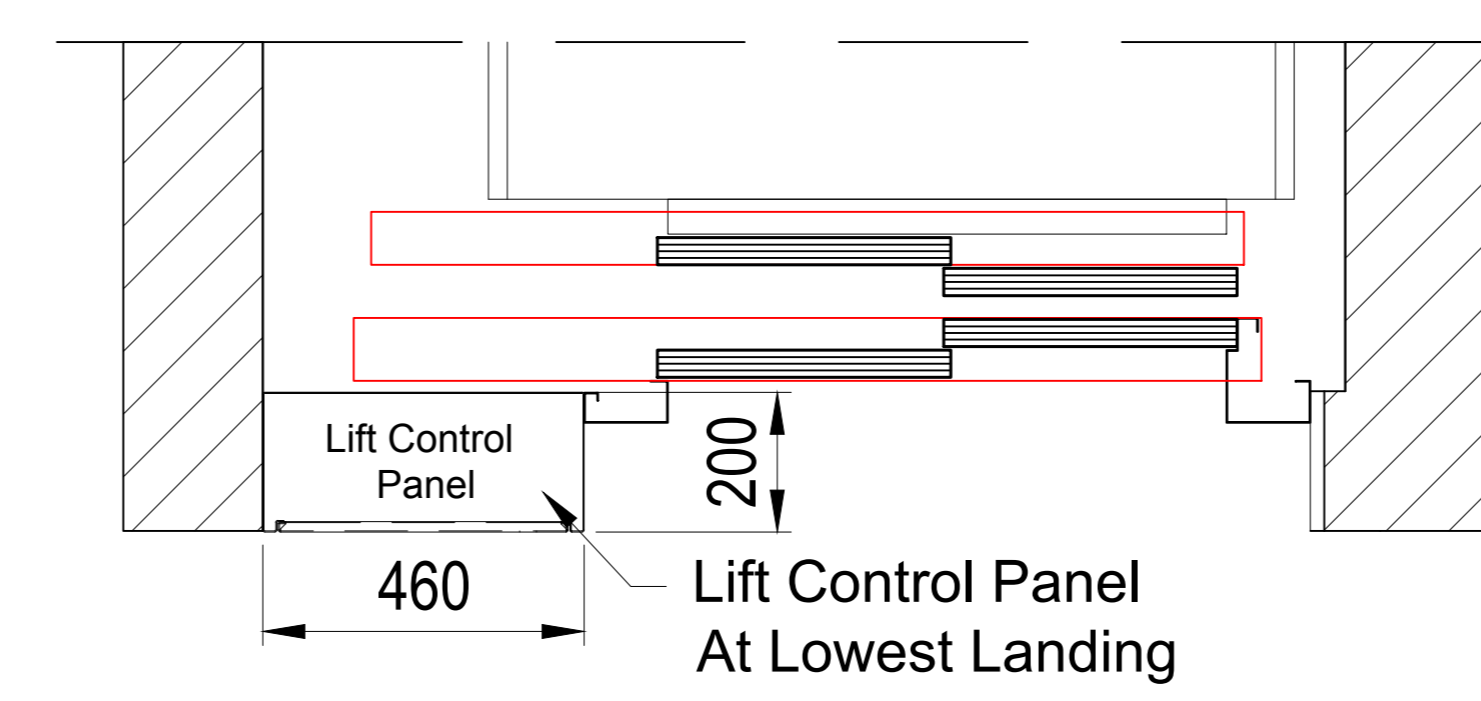
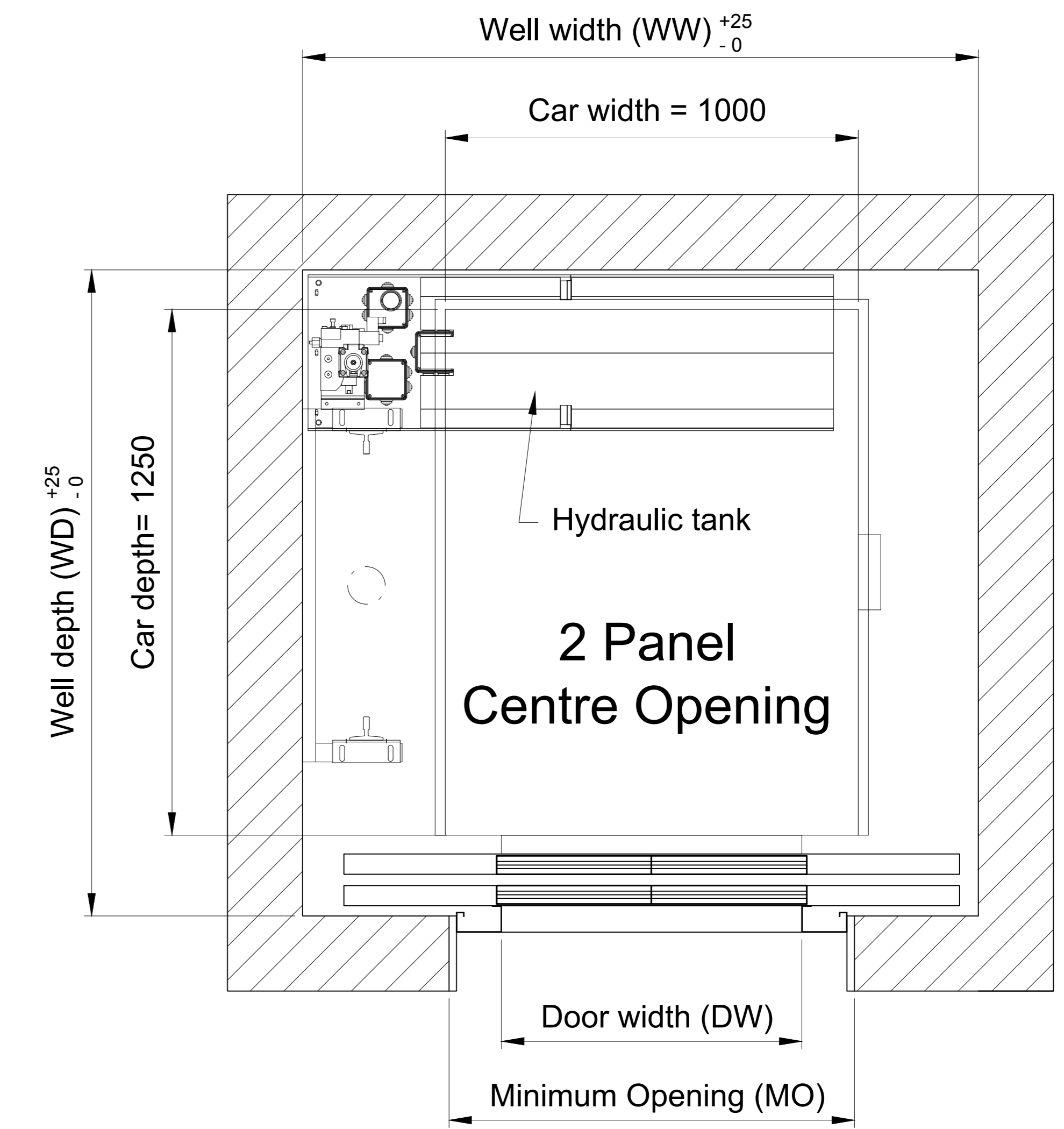
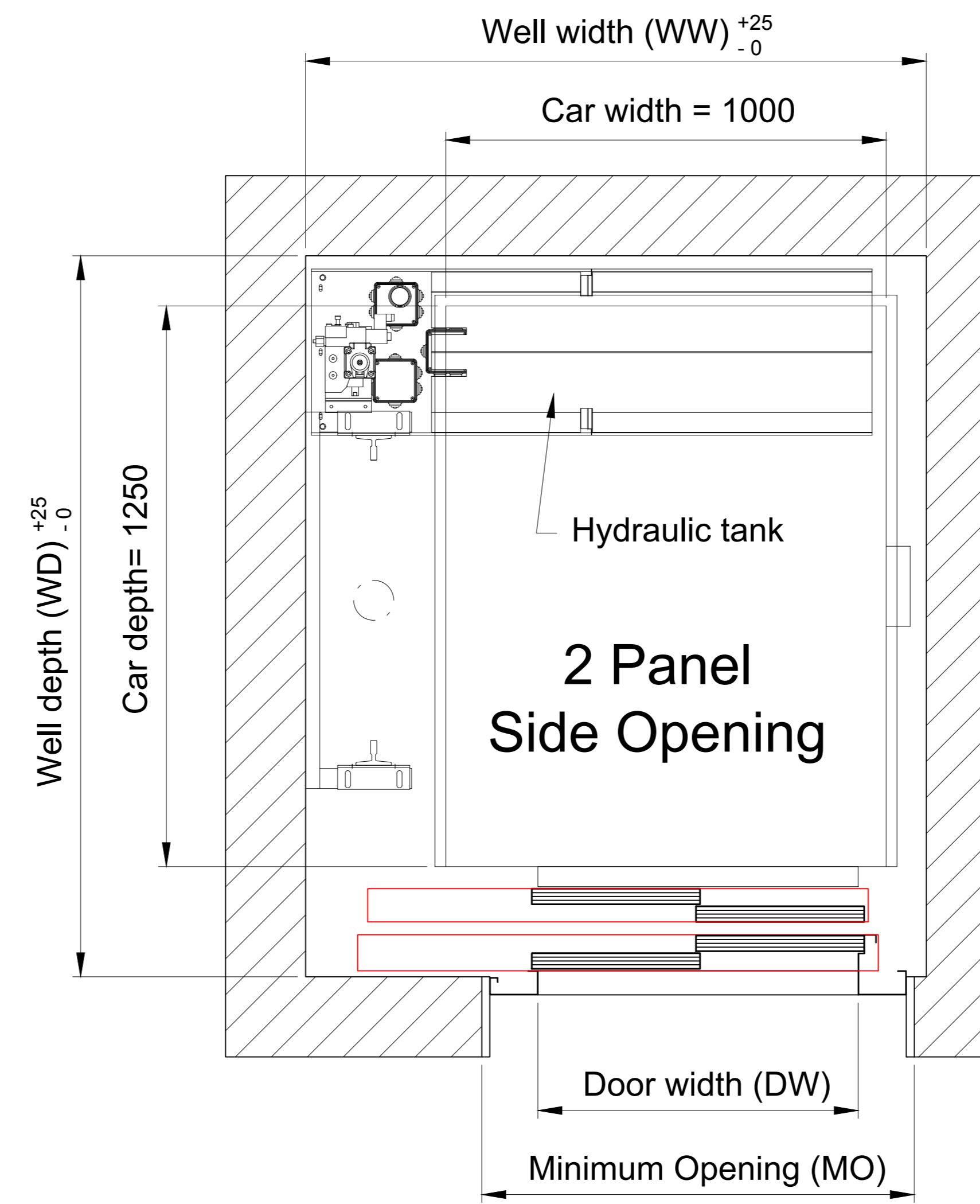
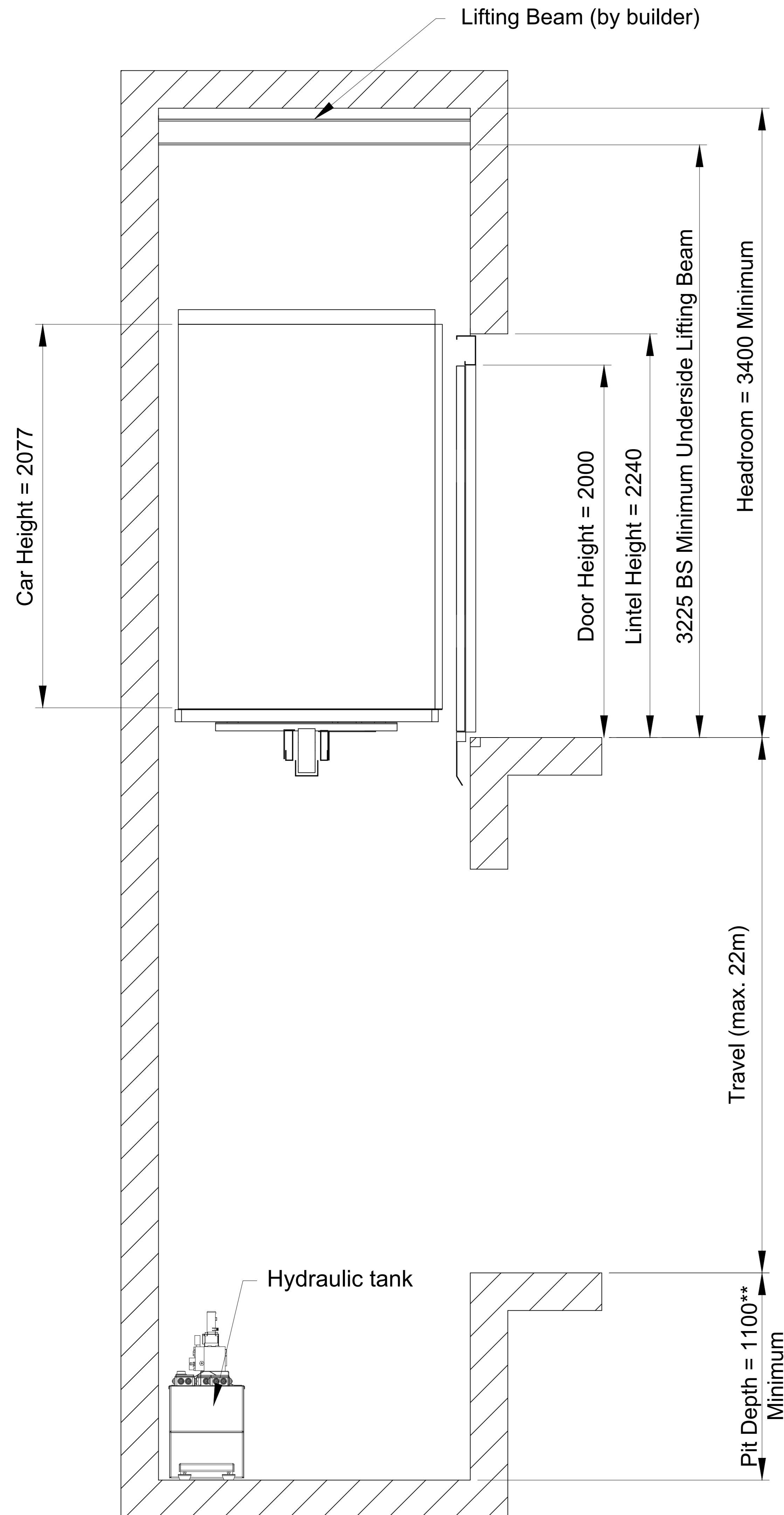

Lift Control Panel must be located at bottom floor only, next to the landing entrance

		Shaft Size						
		Single Entrance		Through Entrance**		Adjacent Entrance		
DW	Door type	WW	WD	WW	WD	WW	WD	MO
800	Side Opening	1500	1725	1820	1800	1800	1675	1100
	Centre Opening	1820	1650	1820	1680			
900	Side Opening			2000	1800			1200
	Centre Opening	2020	1650	2020	1680			

**Waiver:**

This data sheet is for guidance only and must not be used for proper working drawings. Please contact Stannah Lifts for particular details before proceeding. Owing to our policy of continual improvement we reserve the right to alter specifications and dimensions without prior notice

\*\* For through car configuration a 1200mm minimum pit depth is required

**Stannah Lifts Ltd.**  
 Anton Mill, Andover, Hampshire. SP10 2NX  
**Tel: 01264 339090**  
**www.stannahlifts.co.uk**

**Information Sheet**  
**M2-1**  
 18/10/2018