

HOMELIFT

Make sure you understand the contents of this booklet. Keep it handy for reference.

Your Homelift Number is:



Please quote this number on any correspondence

Your local Service Office is:



If your Homelift fails to operate and **BEFORE** contacting the Service Office, please read page 15 of this Handbook.

This can save time and also save you the cost of an unnecessary service call.



CONTENTS

| | PAGE | |
|---|---------------------------------------|----|
| 1 | Introduction | 4 |
| 2 | Pictorial View | 5 |
| 3 | Operating Instructions | 6 |
| 4 | Emergency Operation | 9 |
| 5 | Safety Features | 12 |
| 6 | General Platform Lift Care Procedures | 14 |
| 7 | Trouble Shooting Guide | 15 |
| 8 | Optional Extras | 16 |
| 9 | Notes | 18 |



NOTE: Whilst every effort has been made to ensure the clarity and accuracy of this handbook, we cannot be held responsible for damage or injury resulting from negligence or misuse of this Homelift.

1 INTRODUCTION

This users handbook is to help provide an understanding of correct and safe use of the Homelift.

Your Homelift has been manufactured and installed in accordance with BS 5900.

It is important that you arrange for the lift to receive regular inspection and servicing by a competent person at intervals not exceeding six months, after the 12 months guarantee period.

Failure to ensure servicing is carried out could lead to unreliable or unsafe operation.

For all enquiries regarding servicing, please contact your local Service Office at the address given on page 1 of this booklet.

A Service Log Card supplied by the Service Office will be completed after each service visit.

As requested by the European Legislation On Machinery Regulations, the maximum noise emission has been measured at 63dBA at a distance of 1 metre from the hydraulic powerpack.

Owing to our policy of continual product development, we reserve the right to alter specifications and dimensions without prior notice. At the date of publication this manual was up-to-date and should there be any significant differences we will endeavour to advise you with an addendum.

2 PICTORIAL VIEW

PLEASE NOTE:

The external appearance of your Homelift may differ slightly from that shown below.

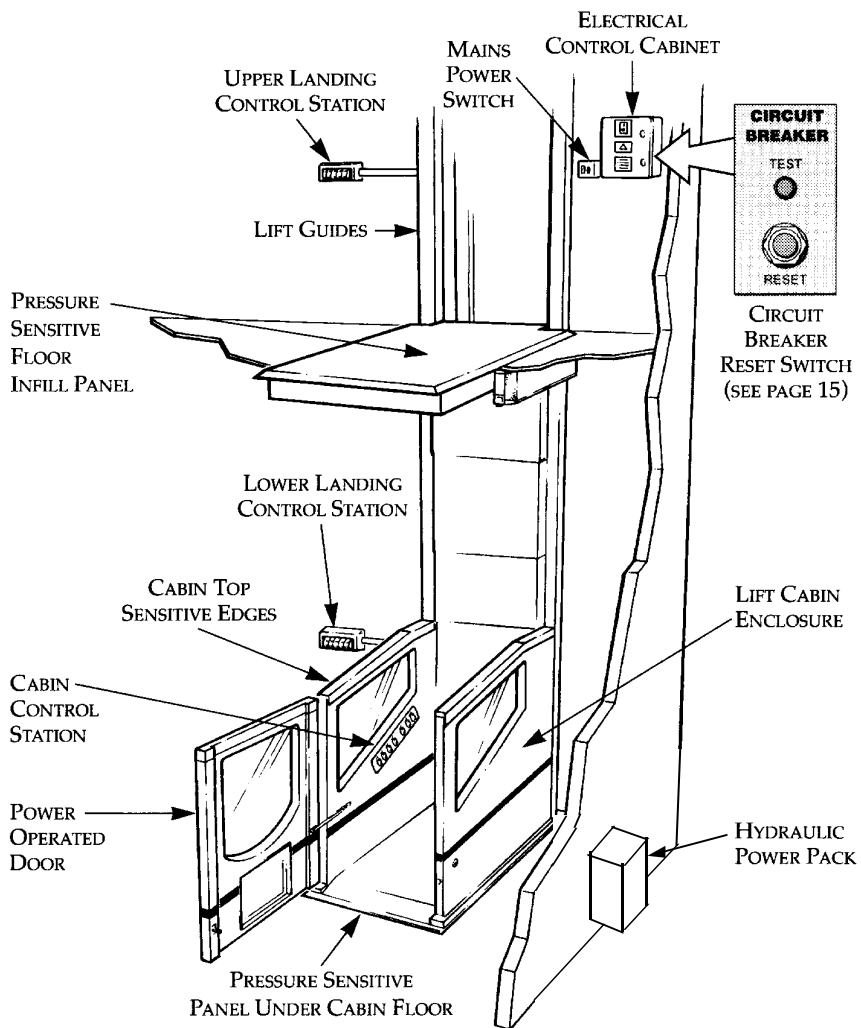

3 OPERATING INSTRUCTIONS



WARNING - Before using your Homelift, please ensure that you read and familiarise yourself with these instructions.

Intended Use of the Homelift.

- The Homelift must not be overloaded. The maximum rated load is 230kg (36 stone).



OR



- The Homelift is intended for the transportation of seated persons and is not intended for use by standing persons.
- Children should not be allowed to tamper or play with the Homelift. Joyriding can be dangerous. Check that pets or any obstructions are not in the way before using the Homelift.
- When the lift is travelling ensure that the passengers limbs are inboard of the cabin enclosure.
- Never leave objects resting against the cabin door or cabin sides.
- Never prop the cabin door open.
- If the lift is to be unused for an extended period of time (eg holidays) the cabin enclosure should be parked at the lower floor level. The mains power switch can be switched OFF but ensure that the cabin light switch is also in the OFF position so as to ensure that the emergency battery back-up power is not drained. (see page 9).
- It is recommended that wheelchair users reverse into the lift cabin for ease of use.
- It may be necessary at times to run your Homelift a couple of times when it has been left for a period of time or during cold weather to warm the hydraulic oil to ensure smooth operation.

TO OPERATE YOUR LIFT USING THE LANDING CONTROL STATIONS

“Up” and “Down” Buttons (Black)

NOTE: The lift will only run with the cabin door closed. To call or send the lift using the landing control station, press the “Up” or “Down” button as required. A momentary press only is required to start the lift travelling. The lift will stop automatically at the designated floor level.

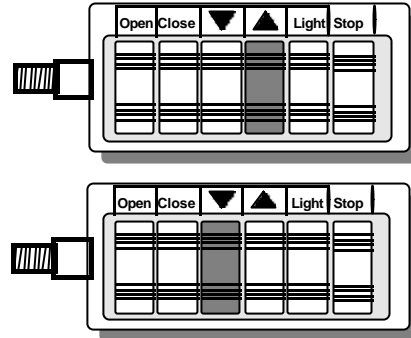

“Stop” Button (Red)

In an emergency, the lift may be stopped when it is travelling in either direction by pressing the stop button. A momentary press only is required to stop the lift. The lift may be restarted after a delay of 3 seconds by pressing the appropriate “Up” or “Down” button.

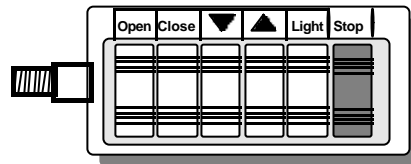

“Door Open” and “Door Close” Buttons (Green)

Movement of the powered door in order to enter or exit the lift cabin is controlled by the appropriate “Door Open” or “Door Close” button. A momentary press only is required to fully open or close the door.

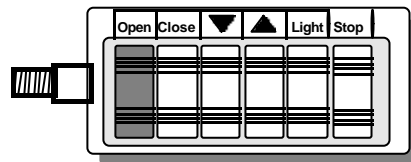

The door can only be powered open when the lift cabin is at a floor level.

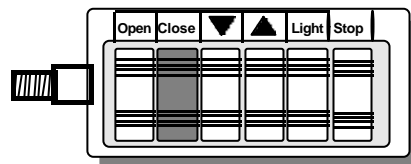

The door is automatically locked on closing (see page 9 for Manual Emergency Release).

TO OPERATE YOUR LIFT USING THE LANDING CONTROL STATIONS

“LIGHT” Switch (Blue)

The cabin lights can be switched from the landing control stations and will turn the light on or off unless the lift is in use. The light will come on when any button in the cabin or on the landing (other than stop) is pressed. Three minutes after the lift operation the light will switch off. The light will stay on if the alarm button is pressed. If any button is then pressed it will reset the system and the light will turn off after three minutes.

TO OPERATE YOUR LIFT USING THE CABIN CONTROL STATION

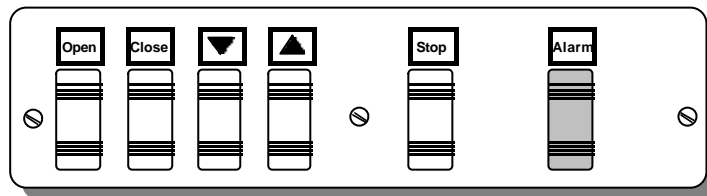

A set of push buttons are provided in the lift cabin which duplicate most of the functions described on the previous page for the landing push stations. In addition, an alarm button is provided.

“ALARM” Button (Yellow)

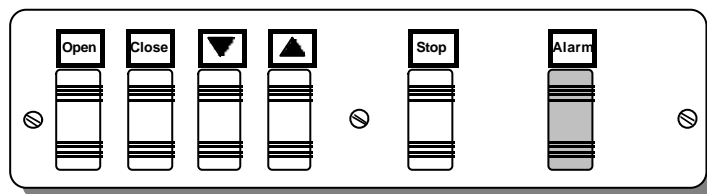

An audible alarm (Normally fitted inside the electrical control cabinet) will sound when the “ALARM” button is pressed. Release the button to stop the alarm. Ensure that the alarm is recognised by all occupants of the dwelling and where necessary, by neighbours.

4 EMERGENCY OPERATION

Emergency Back-up Supply

The lift is fitted with automatic battery back-up system for use in the remote event of a **mains** power failure to either the building or the lift. The system allows the lift to be lowered to the lower floor level and to open and close the cabin powered door by pressing the cabin or landing push buttons in the normal way.

All pressure sensitive safety surfaces are still operable when lowering the lift and operating the door.

Movement of the lift in the up direction will not be possible. The cabin lights and the alarm will also be operational for a limited time.

The battery back-up system is automatically recharged from the mains supply when the lift is fully operational.

Manual Lowering of the Lift

A manually operated hydraulic valve is located on the hydraulic power pack which permits the cabin, even in the case of **total** power failure to be lowered in an emergency to the lower level where the passenger(s) can be evacuated.



NOTE: Emergency operation of the lift must only be undertaken by an authorised person who has had instructions in the correct procedure as described on page 10.

The lift cabin must be under constant surveillance whilst under emergency operation since all sensitive surfaces on the lift are inoperable.

Ensure that the lift and lift-way are clear and that nobody is near the lift.

Lift Manual Lowering Procedure

This procedure must only be undertaken in an emergency due to **total** loss of power to the lift. Ensure you have read page 9 of this handbook prior to manual lowering of the lift.

- 1 Switch off the lift mains electrical supply.
- 2 Ensure that the cabin door is closed and locked.
- 3 Ensure that there are no obstructions under the lift cabin or within the liftway area.
- 4 Remove the lid on the hydraulic power pack enclosure to expose the lift power pack.
- 5 Locate the **RED** manual lowering knob found on the front face of the manifold block.
- 6 Inform the trapped passenger(s) within the lift cabin that the lift is about to be lowered and ensure that the passenger's limbs are inboard of the cabin enclosure.
- 7 Pull the manual lowering Knob to lower the lift. The lift will stop at any time when the knob is released. Release the knob when the lift cabin is seated on the floor at the lower level. Replace the lid on the powerpack enclosure.

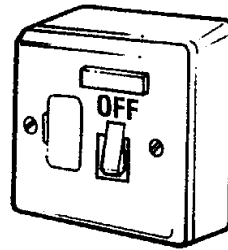

Passenger Release Procedure

- 8 Locate the cabin door lock release key.
- 9 Remove the plastic grommet which gives access to the door lock and is found on the cabin outer side cover.
- 10 Insert the key into the lock and turn clockwise 90° until the latch releases the door.
- 11 Manually open the cabin door. (Light pressure will be required to disengage the automatic door mechanism)
- 12 Release the passenger(s)
- 13 Once the passenger(s) have been released, leave the lift switched off, manually close and lock the cabin door and telephone the Lift Engineers Emergency Service to attend to the breakdown.

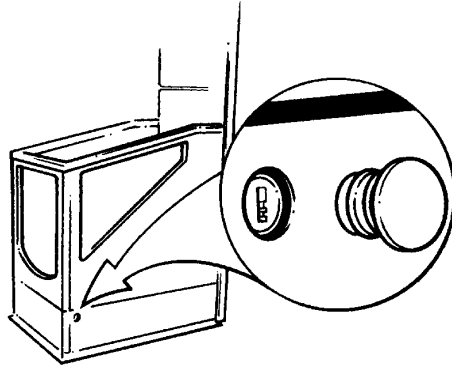

WARNING: No attempt should be made by a passenger to exit the lift cabin without the lift being parked at a designated floor level.

Always ensure that the key has been removed before the lift makes any journeys.

5 SAFETY FEATURES

Your Homelift has many built-in safety features to protect the user and other occupants within the dwelling.

It is important that the user of the lift is familiar with some of these integral features. They are listed below:

- 1 Door Close Timer.** If the cabin door is left open, it will automatically close after a pre-set interval has elapsed. This time can be adjusted by Service Personnel to suit your requirements. (NB. This feature is overridden if the door is manually opened for emergency release)

- 2 Door Sensitive Protection Device:**

If the cabin door opens or closes onto an obstruction, a protective device will automatically cut power to the door preventing any further movement. Travel away from the obstruction can then be initiated by pressing the appropriate “Door OPEN” or “Door CLOSE” button.

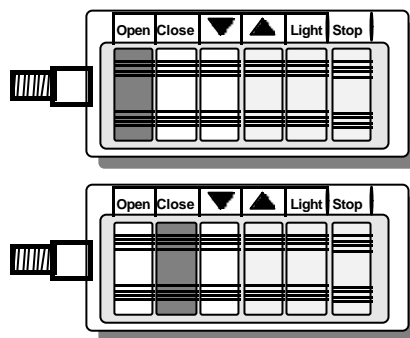

- 3 Re-levelling (Anti Creep Device)**

This ensures that if the lift creeps downwards when parked at the upper floor level for an extended period of time, it will automatically re-level back up to floor level.

- 4 Ultimate Limit Switch:** This switch is positioned at the top of the lift guide rails at the upper floor level. If the activation roller is pressed it will prevent any further movement of the lift under power in either direction of travel. If the switch is activated call your local Service Office.

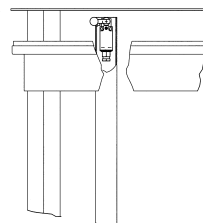

5 Pressure Sensitive Surfaces: These stop the lift automatically if they meet an obstruction during travel of the lift.

A Lift Travelling Upwards: Pressure sensitive surfaces are provided to the upper surface of the floor infill panel, the top periphery of the cabin enclosure, and to the panel under the cabin floor. These will stop the lift if they meet an obstruction when the lift is travelling in the “up” direction.

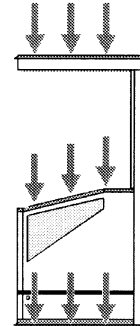

B Lift Travelling Downwards: Pressure sensitive surfaces are provided to the underside of the floor infill panel and to the underside of the cabin floor. These will stop the lift if they meet an obstruction when the lift is travelling in the “Down” direction.

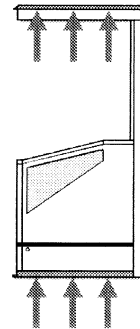

To remove any obstructions, reverse the direction of travel for a short distance by pressing the “up” or “down” button as appropriate.

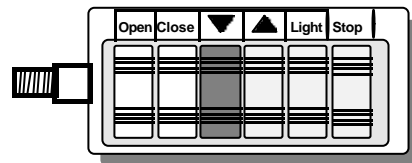
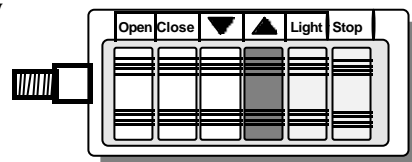

6 GENERAL HOMELIFT CARE PROCEDURES

Cleaning

- Paint Finishes: These should be cleaned with a soft cloth using an aerosol type of furniture polish.
- Cabin Vision Panels: These should be cleaned with a damp soft cloth and mild detergent. Ensure that excess water is squeezed out prior to cleaning.
- Cabin Carpet: This can be vacuumed and cleaned when necessary using any good carpet shampoo. Do not saturate the carpet with water.

NB. Never use abrasives to clean the Homelift decor.



DISMANTLING/REMOVAL OF HOMELIFT

You should not attempt to dismantle any parts of the Homelift. Such work should be entrusted only to competent personnel with relevant expert knowledge and training.

Advise any malfunctions of the Lift operation or lighting to the Service Office or to our service personnel when they are next in attendance.

7 TROUBLE SHOOTING GUIDE

If your Homelift fails to operate check the following list before contacting your local service office - it could save you time and the cost of an unnecessary service call:

| FAULT | CURE |
|------------------------------------------------------------------------------------------------------------------------------|------------------------------------------------------------------------------------------------------------------------------------------------|
| Mains power switch is in the OFF position. | Switch mains power to ON position. |
| Mains fuse has “blown” confirmed by loss of light on mains power switch) | Replace 10 amp fuse in the mains power switch. |
| Circuit breaker, positioned on the front of the electrical control panel, has “tripped”. | Reset by pressing the green button on the front of the control panel. NB If the circuit breaker repeatedly trips - call Service Office. |
| Cabin door is open. | Close the cabin door and ensure that it is automatically locked. |
| The pressure sensitive safety surfaces on the floor infill panel, cabin top or cabin floor panel have sensed an obstruction. | Remove any obstructions, check that the pressure sensitive safety surfaces return to the unobstructed position and are operating “freely”. |

8 OPTIONAL EXTRAS

Isolation Keyswitch Incorporated in Landing Control Stations at both Ground and First Floor

Landing Control Stations are available, if required, with an isolation keyswitch and indicator lamp. The Homelift can be turned either “on” or “off” from either landing station. (This can be compared to a 2-way light switch). The indicator lamp is illuminated when the lift is switched “on” at either floor level.

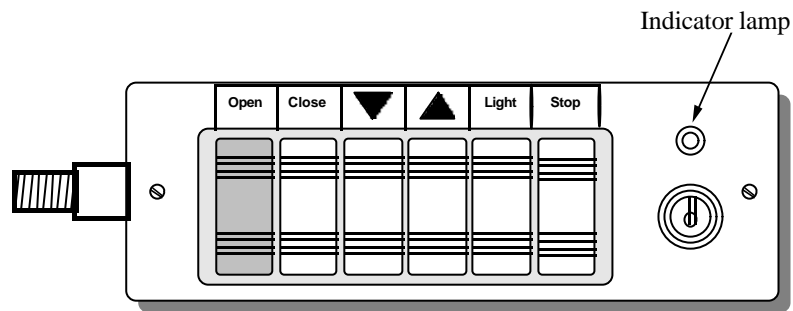

Control station incorporating isolation keyswitch

Telephone

A telephone option is available and is wall mounted on the inside panel of the lift cabin. The telephone can be used to make out-going and in-coming calls but the telephone bell **will not** ring.

Lift in Motion Buzzer

A buzzer is available which sounds when the lift is moving. A yellow rocker switch is mounted to a faceplate which replaces the blank faceplate opposite the cabin control station. If at any time the buzzer needs to be isolated it can be turned off by pressing the rocker switch to the “off” position.

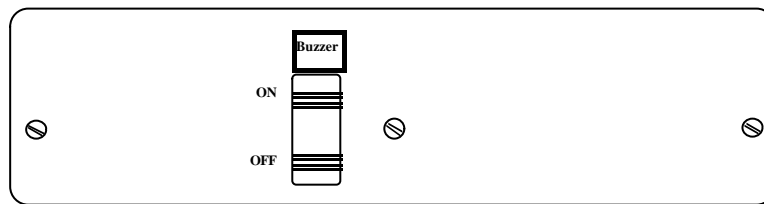

'Lift in motion' buzzer and faceplate

Additional Set of Car Switches

A duplicate set of car switches are available and are mounted opposite the standard cabin control station and operate in exactly the same way.

NOTES



