

TOP FLOOR LANDING CONTROL STATION

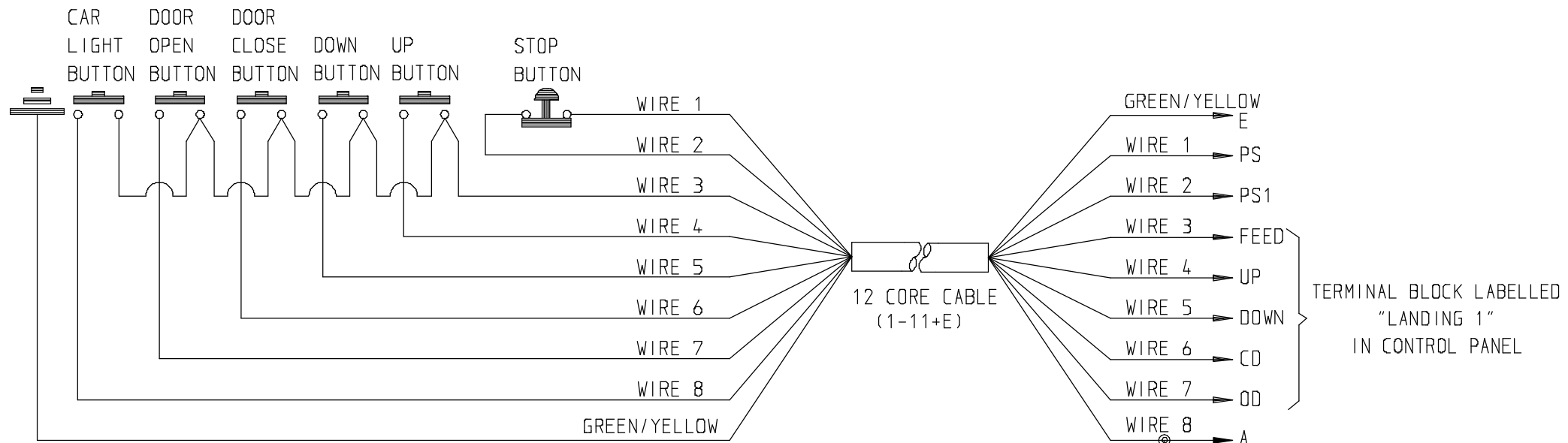

BOTTOM FLOOR LANDING CONTROL STATION

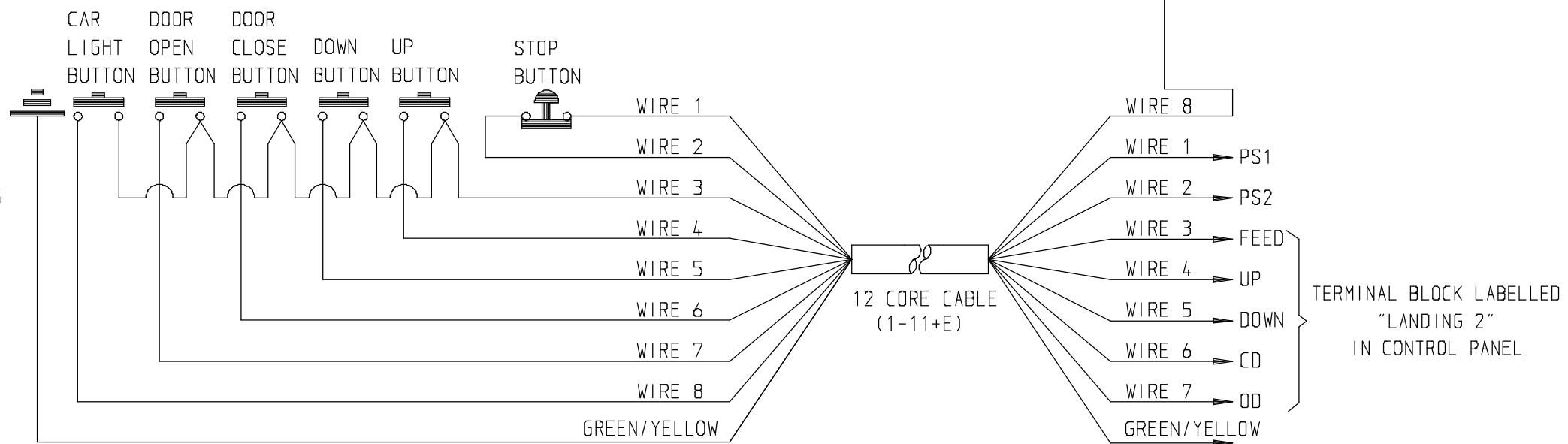

DRAWN: A. HULME DATE: 23/1/96

HOMELIFT LANDING PUSH STATION WIRING



HEAD OFFICE:
Anton Mill Andover Hampshire
SP10 2NX England
Tel: 01264 339090 Fax: 337942

REV A: EARTH WIRE ADDED 28.2.97 AMH
REV B: WIRING UPDATED FOR PCB CONTROLLER 26/3/99 DC

REV C: PUSH BUTTON RETURN DESIGNATIONS ALTERED TO SUIT PCB 11/8/99 DC
REV D: ADDITIONAL WIRING FOR CAR LIGHT BUTTON ADDED 15/10/99 MH

DRAWING NO: 9228/3 D