

# GATE LOCK SIDE FRAME WIRING

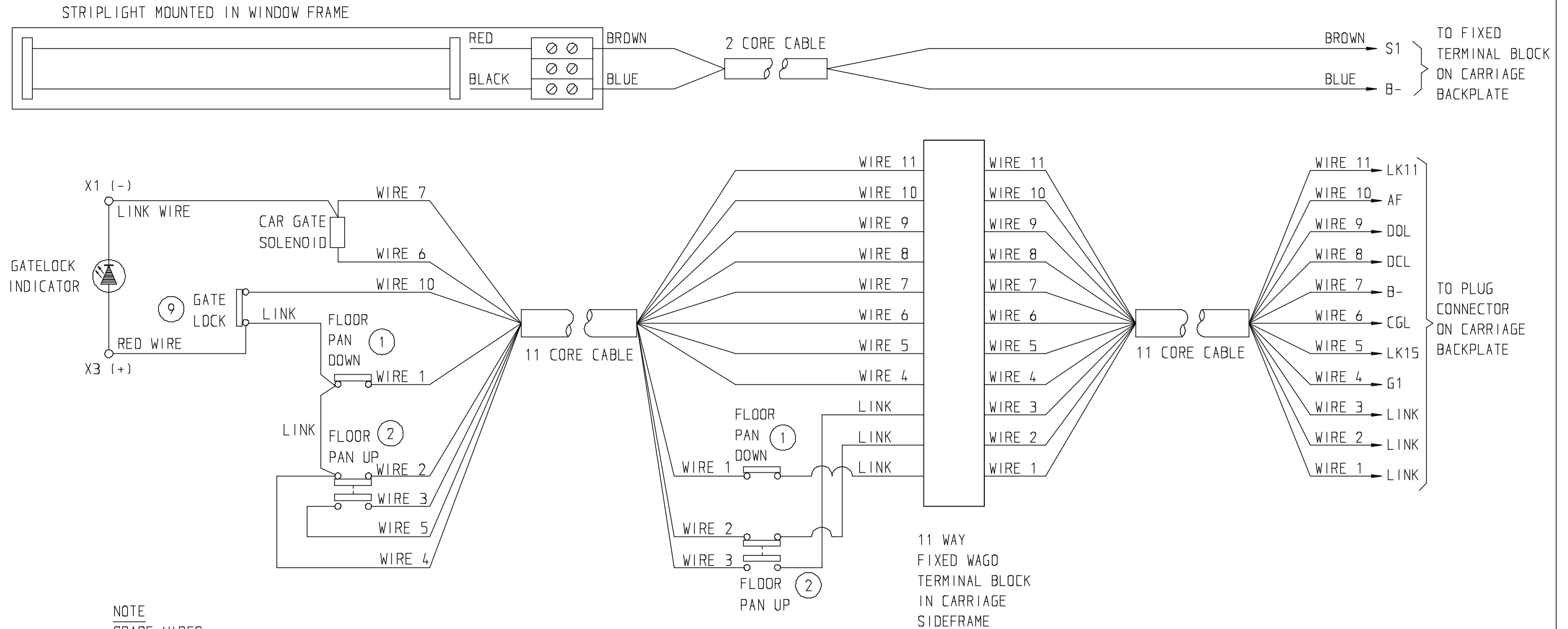

NOTE  
SPARE WIRES  
11  
9  
8

REV A: SWITCH NUMBERING ADDED, WIRE DESTINATION TERMINOLOGY ALTERED 20/1/98 DC  
 REV B: LINK WIRING FROM FLOOR PAN SWITCHES TO TERMINAL BLOCK ALTERED 6/3/98 DC  
 REV C: WIRING TO PUSHES DELETED TO SUIT PCB CONTROLLER 14/10/98 DC  
 REV D: STRIPLIGHTS MOVED TO CARRIAGE SIDEFRAMES 25/9/00 DC  
 REV E: GATELOCK INDICATOR CONNECTION DETAILS ADDED 22/05/01 MH

DRAWN: A. HULME	DATE: 6/11/97
HOMELIFT CARRIAGE WIRING FOR GATE LOCK SIDE FRAME	
HEAD OFFICE: Anton Mill Andover Hampshire SP10 2NX England Tel: 01264 339090 Fax: 337942	
DRAWING NO:	9228/28 <sup>E</sup>